

# Table of Contents

<b>Appendix A: Summary Table of Aviation System Block Upgrades Mapped to Performance Improvement Areas</b>	<b>1</b>
<b>Appendix B – Detailed Aviation System Block Upgrades</b>	<b>7</b>
Performance Improvement Area 1: Greener Airports	9
Thread: Airport Accessibility	9
Module N° B0-65: OPTIMIZATION OF APPROACH PROCEDURES INCLUDING VERTICAL GUIDANCE	11
Module N° B1-65: Optimized Airport Accessibility	17
Performance Improvement Area 1: Greener Airports	22
Thread: Wake Turbulence Separation.	22
Module N° B0-70: Increased Runway Throughput through Wake Turbulence Separation	24
Module N° B1-70: Increased Runway Throughput through Dynamic Wake Turbulence Separation	29
Module N° B2-70: Advanced Wake Turbulence Separation (Time-based)	36
Performance Improvement Area 1: Greener Airports	40
Thread: AMAN/DMAN	40
Module N° B0-15: IMPROVE TRAFFIC FLOW THROUGH RUNWAY SEQUENCING (AMAN/DMAN)	41
Module N° B1-15: Improved Airport operations through Departure, Surface and Arrival Management	47
Module N° B2-15: Linked AMAN/DMAN	55
Module N° B3-15: Integration AMAN/DMAN/SMAN	59
Performance Improvement Area 1: Greener Airports	62
Thread: Surface Operations	62
Module N° B0-75 Safety and Efficiency of Surface Operations (A-SMGCS Level 1-2)	64
Module N° B1-75: Enhanced Safety and Efficiency of Surface Operations (A-SMGCS/SURF-IA) and EVS	70
Module N° B2-75: Optimized Surface Routing and Safety	76
Benefits (A-SMGCS Level 3-4 and SVS)	76
Performance Improvement Area 1: Greener Airports	84
Thread: Airport Collaborative Decision Making	84
Module N° B0-80: Improved Airport Operations through Airport-CDM	86
Module N° B1-80: Optimized Airport Operations through A-CDM Total Airport Management	91
Performance Improvement Area 1: Greener Airports	95
Thread: Remote Aerodrome Control Towers	95
Module N° B1-81: Remotely Operated Aerodrome Control	97
Performance Improvement Area 2: Globally Interoperable Systems and Data - Through Globally Interoperable System Wide Information Management	106
Thread: FF/ICE	106
Module N° B0-25: Increased Interoperability, Efficiency and Capacity through Ground-Ground Integration	107
Module N° B1-25: Increased Interoperability, Efficiency and Capacity through FF-ICE/1 application before Departure	112
Module N° B2-25 Improved Coordination through multi-centre Ground-Ground Integration: (FF-ICE/1 and Flight Object, SWIM)	116
Module N° B3-25 Improved Operational Performance through the introduction of Full FF-ICE	119
Performance Improvement Area 2: Globally Interoperable Systems and Data - Through Globally Interoperable System Wide Information Management	123
Thread: Digital Aeronautical Information Management	123
Module N° B0-30: Service Improvement through Digital Aeronautical Information Management	125

Module N° B1-30: Service Improvement through Integration of all Digital ATM Information	129
Performance Improvement Area 2: Globally Interoperable Systems and Data - Through Globally Interoperable System Wide Information Management	132
Thread: System Wide Information Management	132
Module N° B1-31: Performance Improvement through the application of System Wide Information Management (SWIM)	134
Module N° B2-31: Enabling Airborne Participation in collaborative ATM through SWIM	138
Performance Improvement Area 2: Globally Interoperable Systems and Data - Through Globally Interoperable System Wide Information Management	141
Thread: Improved Meteorological Information	141
Module N° B0-105: Meteorological information supporting enhanced operational efficiency and safety	142
Module N° B1-105: Enhanced Operational Decisions through Integrated Meteorological Information (Planning and Near-term Service)	149
Module N° B3-105: Enhanced Operational Decisions through Integrated Meteorological Information (Near-term and Immediate Service)	156
Performance Improvement Area 3: Optimum Capacity and Flexible Flights – Through Global Collaborative ATM	161
Thread: Free-Routing	161
Module N° B0-10: Improved Operations through Enhanced En-Route Trajectories	163
Module N° B1-10: Improved Operations through Free Routing	173
Module N° B3-10: Traffic Complexity Management	179
Performance Improvement Area 3: Optimum Capacity and Flexible Flights – Through Global Collaborative ATM.	182
Thread: Network Operations	182
Module N° B0-35: Improved Flow Performance through Planning based on a Network-Wide view	184
Module N° B1-35: Enhanced Flow Performance through Network Operational Planning	189
Module N° B2-35: Increased user involvement in the dynamic utilization of the network	193
Performance Improvement Area 3: Optimum Capacity and Flexible Flights – Through Global Collaborative ATM.	197
Thread: Initial Surveillance	197
Module N° B0-84: Initial capability for ground surveillance	199
Performance Improvement Area 3: Optimum Capacity and Flexible Flights – Through Global Collaborative ATM.	203
Thread: Self Separation	203
Module N° B0-85: Air Traffic Situational Awareness (ATSA)	205
Module N° B1-85: Increased Capacity and Efficiency through Interval Management	210
Module N° B2-85 Airborne Separation (ASEP)	215
Module N° B3-85: Airborne Self-Separation (SSEP):	219
Performance Improvement Area 3: Optimum Capacity and Flexible Flights – Through Global Collaborative ATM.	223
Thread: Optimum Flight Levels	223
Module N° B0-86: Improved Access to Optimum Flight Levels through Climb/Descent Procedures using ADS-B	225
Performance Improvement Area 3: Optimum Capacity and Flexible Flights – Through Global Collaborative ATM.	230
Thread: Airborne Collision Avoidance Systems	230
Module N° B0-101: ACAS Improvements	232
Module N° B2-101: New Collision Avoidance System	236
Performance Improvement Area 3: Optimum Capacity and Flexible Flights – Through Global Collaborative ATM.	240
Thread: Safety Nets	240
Module N°B0-102: Increased Effectiveness of Ground-Based Safety Nets	242
Module N°B1-102: Ground-based Safety Nets on Approach	246
Performance Improvement Area 4: Efficient Flight Path – Through Trajectory-based Operations.	250
Thread: Continuous Descent Operations	250

Module N° B0-05: Improved Flexibility and Efficiency in Descent Profiles (CDOs)	252
Module N° B1-05: Improved Flexibility and Efficiency in Descent Profiles (OPDs)	258
Module N° B2-05: Optimized Arrivals in Dense Airspace	262
Module N° B3-05: Full 4D Trajectory-based Operations	267
Performance Improvement Area 4: Efficient Flight Path – Through Trajectory-based Operations	272
Thread: Trajectory-Based Operations	272
Module N° B0-40: Improved Safety and Efficiency through the initial application of Data Link En-Route	274
Module N° B1-40: Improved Traffic Synchronization and Initial Trajectory-Based Operation	280
Performance Improvement Area 4: Efficient Flight Path – Through Trajectory-based Operations.	286
Thread: Continuous Climb Operations	286
Module N° B0-20: Improved Flexibility and Efficiency Departure Profiles	288
Performance Improvement Area 4: Efficient Flight Path – Through Trajectory-based Operations.	293
Thread: Remotely Piloted Aircraft	293
Module N° B1-90 Initial Integration of Remotely-Piloted Aircraft (RPA) Systems into non-segregated airspace	295
Module N° B2-90: Remotely Piloted Aircraft (RPA) Integration in Traffic	300
Module N° B3-90: Remotely Piloted Aircraft (RPA) Transparent Management	306
<b>Appendix C – Dependency Mandates</b>	<b>312</b>
<b>Appendix D - Glossary</b>	<b>314</b>

# Appendix A: Summary Table of Aviation System Block Upgrades Mapped to Performance Improvement Areas

## Performance Improvement Area 1: Greener Airports

Block 0	Block 1	Block 2	Block 3
<p><b><a href="#">B0-65</a></b>  <b>Improved Airport Accessibility</b>                      This is the first step toward universal implementation of <a href="#">GNSS</a>-based approaches</p>	<p><b><a href="#">B1-65</a></b>  <b>Optimized Airport Accessibility</b>                      This is the next step in the universal implementation of <a href="#">GNSS</a>-based approaches</p>		
<p><b><a href="#">B0-70</a></b>  <b>Increased Runway Throughput through Wake Turbulence Separation</b>                      Improved throughput on departure and arrival runways through the revision of current ICAO wake turbulence separation minima and procedures .</p>	<p><b><a href="#">B1-70</a></b>  <b>Increased Runway Throughput through Dynamic Wake Turbulence Separation</b>                      Improved throughput on departure and arrival runways through the dynamic management of wake turbulence separation minima based on the real-time identification of wake turbulence hazards</p>	<p><b><a href="#">B2-70 (*)</a></b>  <b>Advanced Wake Turbulence Separation (Time-based)</b></p>	
<p><b><a href="#">B0-15</a></b>  <b>Improved RunwayTraffic Flow through Sequencing (<a href="#">AMAN/DMAN</a>)</b>                      Time-based metering to sequence departing and arriving flights</p>	<p><b><a href="#">B1-15</a></b>  <b>Improved Airport operations through Departure, Surface and Arrival Management</b>                      Extended arrival metering, Integration of surface management with departure sequencing bring robustness to runways management and increase airport performances and flight efficiency</p>	<p><b><a href="#">B2-15</a></b>  <b>Linked</b>                      Synchronized AMAN/DMAN will promote more agile and efficient en-route and terminal operations</p>	<p><b><a href="#">B3-15</a></b>  <b>Integrated <a href="#">AMAN/DMAN/SMAN</a></b>                      Fully synchronized network management between departure airport and arrival airports for all aircraft in the air traffic system at any given point in time</p>
<p><b><a href="#">B0-75</a></b>  <b>Improved Runway Safety (<a href="#">A-SMGCS</a> Level 1-2)</b>                      Airport surface surveillance for <a href="#">ANSP</a></p>	<p><b><a href="#">B1-75</a></b>  <b>Enhanced Safety and Efficiency of Surface Operations (<a href="#">A-SMGCS/SURF IA</a>) and EVS</b>                      Airport surface surveillance for <a href="#">ANSP</a> and flight crews with safety logic, cockpit moving map displays and visual systems for taxi operations</p>	<p><b><a href="#">B2-75</a></b>  <b>Optimized Surface Routing and Safety Benefits (<a href="#">A-SMGCS</a> Level 3-4 and SVS)</b>                      Taxi routing and guidance evolving to trajectory based with ground / cockpit monitoring and data link delivery of clearances and information. Cockpit synthetic visualisation systems</p>	
<p><b><a href="#">B0-80</a></b>  <b>Improved Airport Operations through Airport-<a href="#">CDM</a></b>                      Airport operational improvements through the way operational partners at airports work together</p>	<p><b><a href="#">B1-80</a></b>  <b>Optimized Airport Operations through Airport-<a href="#">CDM</a></b>                      Airport operational improvements through the way operational partners at airports work together</p>		
	<p><b><a href="#">B1-81</a></b>  <b>Remote Operated Aerodrome Control Tower</b>                      Remotely operated Aerodrome Control Tower contingency and remote provision of ATS to aerodromes through visualisation systems and tools</p>		

## Performance Improvement Area 2: Globally Interoperable Systems and Data – Through Globally Interoperable System Wide Information Management

Block 0	Block 1	Block 2	Block 3
<p><b><a href="#">B0-25</a></b>  <b>Increased Interoperability, Efficiency and Capacity through Ground-Ground Integration</b>                      Supports the coordination of ground-ground data communication between <a href="#">ATSU</a> based on ATS Inter-facility Data Communication (AIDC) defined by ICAO Document 9694</p>	<p><b><a href="#">B1-25</a></b>  <b>Increased Interoperability, Efficiency and Capacity through <a href="#">FF-ICE/1</a> application before Departure</b>                      Introduction of FF-ICE step 1, to implement ground-ground exchanges using common flight information reference model, <a href="#">FIXM</a>, XML and the flight object used before departure</p>	<p><b><a href="#">B2-25</a></b>  <b>Improved Coordination through multi-centre Ground-Ground Integration: (FF-ICE/1 and Flight Object, SWIM)</b>                      FF-ICE supporting trajectory-based operations through exchange and distribution of information for multicentre operations using flight object implementation and <a href="#">IOP</a> standards</p>	
<p><b><a href="#">B0-30</a></b>  <b>Service Improvement through Digital Aeronautical Information Management</b>                      Initial introduction of digital processing and management of information, by the implementation of <a href="#">AIS</a>/AIM making use of <a href="#">AIXM</a>, moving to electronic <a href="#">AIP</a> and better quality and availability of data</p>	<p><b><a href="#">B1-30</a></b>  <b>Service Improvement through Integration of all Digital ATM Information</b>                      Implementation of the ATM information reference model integrating all ATM information using UML and enabling XML data representations and data exchange based on internet protocols with WXXM for meteorological information</p>		<p><b><a href="#">B3-25</a></b>  <b>Improved Operational Performance through the introduction of Full <a href="#">FF-ICE</a></b>                      All data for all relevant flights systematically shared between air and ground systems using SWIM in support of collaborative ATM and trajectory-based operations</p>
	<p><b><a href="#">B1-31</a></b>  <b>Performance Improvement through the application of System Wide Information Management (SWIM)</b>                      Implementation of SWIM services (applications and infrastructure) creating the aviation intranet based on standard data models, and internet-based protocols to maximize interoperability</p>	<p><b><a href="#">B2-31</a></b>  <b>Enabling Airborne Participation in collaborative ATM through SWIM</b>                      Connection of the aircraft an information node in SWIM enabling participation in collaborative ATM processes with access to rich voluminous dynamic data including meteorology</p>	
<p><b><a href="#">B0-105</a></b>  <b>Meteorological Forecasts, Warnings and Alerts.</b>                      Global, regional and local meteorological information:</p> <ul style="list-style-type: none"> <li>• Aerodrome warnings to give concise information of meteorological conditions that could adversely affect all aircraft at an aerodrome including windshear.</li> <li>• Forecasts provided by world area forecast centres (WAFC), volcanic ash advisory centres (VAAC) and tropical cyclone advisory centres (TCAC)</li> </ul> <p>This information will support flexible airspace management, improved situational awareness and collaborative decision making, and dynamically-optimized flight trajectory planning.</p>	<p><b><a href="#">B1-105</a></b>  <b>Better Operational Decisions through Integrated Weather Information (Strategic &gt;40 Minutes)</b>                      Weather information supporting automated decision process or aids involving: weather information, weather translation, ATM impact conversion and ATM decision support</p>		<p><b><a href="#">B3-105</a></b>  <b>Better Operational Decisions through Integrated Weather Information (Tactical &lt;40 Minutes)</b>                      Weather information supporting both air and ground automated decision support aids for implementing weather mitigation strategies</p>

## Performance Improvement Area 3: Optimum Capacity and Flexible Flights – Through Global Collaborative ATM

Block 0	Block 1	Block 2	Block 3
<p><b><u>B0-10</u></b>  <b>Improved Operations through Enhanced En-Route Trajectories</b>                      To allow the use of airspace which would otherwise be segregated (i.e. military airspace) along with flexible routing adjusted for specific traffic patterns. This will allow greater routing possibilities, reducing potential congestion on trunk routes and busy crossing points, resulting in reduced flight length and fuel burn.</p>	<p><b><u>B1-10</u></b>  <b>Operations through Free Routing</b>                      Introduction of free routing in defined airspace, where the flight plan is not defined as segments of a published route network or track system to facilitate adherence to the user-preferred profile</p>	<p><b><u>B2-35</u></b>  <b>Increased user involvement in the dynamic utilization of the network.</b>                      Introduction of <b>CDM</b> applications supported by SWIM that permit airspace users manage competition and prioritisation of complex <b>ATFM</b> solutions when the network or its nodes (airports, sector) no longer provide capacity commensurate with user demands</p>	<p><b><u>B3-10</u></b>  <b>Traffic Complexity Management</b>                      Introduction of complexity management to address events and phenomena that affect traffic flows due to physical limitations, economic reasons or particular events and conditions by exploiting the more accurate and rich information environment of a SWIM-based ATM</p>
<p><b><u>B0-35</u></b>  <b>Improved Flow Performance through Planning based on a Network-Wide view</b>                      Collaborative <b>ATFM</b> measure to regulate peak flows involving departure slots, managed rate of entry into a given piece of airspace for traffic along a certain axis, requested time at a way-point or an <b>FIR</b>/sector boundary along the flight, use of miles-in-trail to smooth flows along a certain traffic axis and re-routing of traffic to avoid saturated areas</p>	<p><b><u>B1-35</u></b>  <b>Enhanced Flow Performance through Network Operational Planning</b>  <b>ATFM</b> techniques that integrate the management of airspace, traffic flows including initial user driven prioritisation processes for collaboratively defining <b>ATFM</b> solutions based on commercial/operational priorities</p>		

## Performance Improvement Area 3: Optimum Capacity and Flexible Flights – Through Global Collaborative ATM

Block 0	Block 1	Block 2	Block 3
<p><b>B0-84 Initial Capability for Ground-Based Cooperative Surveillance</b></p> <p>Ground surveillance supported by <a href="#">ADS-B</a> OUT and/or wide area multilateration systems will improve safety, especially search and rescue and capacity through separation reductions. This capability will be expressed in various ATM services, e.g. traffic information, search and rescue and separation provision.</p>			
<p><b>B0-85</b> <b>Air Traffic Situational Awareness (ATSA)</b></p> <p>Two ATSA (<i>Air Traffic Situational Awareness</i>) applications which will enhance safety and efficiency by providing pilots with the means to achieve quicker visual acquisition of targets:</p> <ul style="list-style-type: none"> <li>• AIRB (Enhanced Traffic Situational Awareness during Flight Operations).</li> <li>• VSA (Enhanced Visual Separation on Approach).</li> </ul>	<p><b>B1-85</b> <b>Increased Capacity and Flexibility through Interval Management</b></p> <p>Interval Management (IM) improves the management of traffic flows and aircraft spacing. Precise management of intervals between aircraft with common or merging trajectories maximizes airspace throughput while reducing <a href="#">ATC</a> workload along with more efficient aircraft fuel burn..</p>	<p><b>B2-85</b> <b>Airborne Separation (ASEP)</b></p> <p>Operational benefits through temporary delegation of responsibility to the flight deck for separation provision between suitably equipped designated aircraft, thus reducing the need for conflict resolution clearances while reducing <a href="#">ATC</a> workload and enabling more efficient flight profiles.</p>	<p><b>B3-85</b> <b>Self-Separation (SSEP)</b></p> <p>To create operational benefits through total delegation of responsibility to the flight deck for separation provision between suitably equipped aircraft in designated airspace, thus reducing the need for conflict resolution clearances while reducing <a href="#">ATC</a> workload and enabling more efficient flight profiles</p>
<p><b>B0-86</b> <b>Improved access to Optimum Flight Levels through Climb/Descent Procedures using <a href="#">ADS-B</a></b></p> <p>This prevents an aircraft being trapped at an unsatisfactory altitude and thus incurring non-optimal fuel burn for prolonged periods. The main benefit of <a href="#">ITP</a> is significant fuel savings and the uplift of greater payloads</p>			
<p><b>B0-101</b> <b>ACAS Improvements</b></p> <p>To provide short term improvements to existing airborne collision avoidance systems (ACAS) to reduce nuisance alerts while maintaining existing levels of safety. This will reduce trajectory perturbation and increase safety in cases where there is a breakdown of separation.</p>	<p><b>B2-101</b> <b>New Collision Avoidance System</b></p> <p>Implementation of Airborne Collision Avoidance System (ACAS) adapted to trajectory-based operations with improved surveillance function supported by <a href="#">ADS-B</a> aimed at reducing nuisance alerts and deviations. The new system will enable more efficient operations and procedures while complying with safety regulations</p>		
<p><b>B0-102: Increased Effectiveness of Ground-based Safety Nets</b></p> <p>This module provides improvements to the effectiveness of the ground-based safety nets assisting the Air Traffic Controller and generating, in a timely manner, alerts of an increased risk to flight safety (such as short terms conflict alert, area proximity warning and minimum safe altitude warning).</p>	<p><b>B1-102: Ground-based Safety Nets on Approach</b></p> <p>This module enhances the safety provide by the previous module by reducing the risk of controlled flight into terrain accidents on final approach through the use of Approach Path Monitor (APM).</p>		

**Performance Improvement Area 4:  
Efficient Flight Path – Through Trajectory-based Operations**

Block 0	Block 1	Block 2	Block 3
<p><b><u>B0-05</u></b> <b>Improved Flexibility and Efficiency in Descent Profiles (CDOs)</b> Deployment of performance-based airspace and arrival procedures that allow the aircraft to fly their optimum aircraft profile taking account of airspace and traffic complexity with continuous descent operations (CDOs)</p>	<p><b><u>B1-05</u></b> <b>Improved Flexibility and Efficiency in Descent Profiles (OPDs)</b> Deployment of performance-based airspace and arrival procedures that allow the aircraft to fly their optimum aircraft profile taking account of airspace and traffic complexity with Optimized Profile Descents (OPDs)</p>	<p><b><u>B2-05</u></b> <b>Optimized arrivals in dense airspace.</b> Deployment of performance-based airspace and arrival procedures that optimize the aircraft profile taking account of airspace and traffic complexity including Optimized Profile Descents (OPDs), supported by Trajectory-Based Operations and self-separation</p>	
<p><b><u>B0-40</u></b> <b>Improved Safety and Efficiency through the initial application of Data Link En-Route</b> Implementation of an initial set of data link applications for surveillance and communications in <a href="#">ATC</a></p>	<p><b><u>B1-40</u></b> <b>Improved Traffic Synchronization and Initial Trajectory-Based Operation.</b> Improve the synchronization of traffic flows at en-route merging points and to optimize the approach sequence through the use of 4DTRAD capability and airport applications, e.g.; <a href="#">D-TAXI</a>, via the air ground exchange of aircraft derived data related to a single controlled time of arrival (CTA).</p>		<p><b><u>B3-05</u></b> <b>Full 4D Trajectory-based Operations</b> Trajectory-based operations deploys an accurate four-dimensional trajectory that is shared among all of the aviation system users at the cores of the system. This provides consistent and up-to-date information system-wide which is integrated into decision support tools facilitating global ATM decision-making</p>
<p><b><u>B0-20</u></b> <b>Improved Flexibility and Efficiency in Departure Profiles</b> Deployment of departure procedures that allow the aircraft to fly their optimum aircraft profile taking account of airspace and traffic complexity with continuous climb operations (CCOs)</p>			
	<p><b><u>B1-90</u></b> <b>Initial Integration of Remotely Piloted Aircraft (RPA) Systems into non-segregated airspace</b> Implementation of basic procedures for operating RPAs in non-segregated airspace including detect and avoid</p>	<p><b><u>B2-90</u></b> <b>RPA Integration in Traffic</b> Implements refined operational procedures that cover lost link (including a unique squawk code for lost link) as well as enhanced detect and avoid technology</p>	<p><b><u>B3-90</u></b> <b>RPA Transparent Management</b> RPA operate on the aerodrome surface and in non-segregated airspace just like any other aircraft</p>



This Page Intentionally Left Blank

## Appendix B – Detailed Aviation System Block Upgrades

This Appendix presents the detailed modules which make up each block upgrade. The modules are presented by Performance Improvement Area (or Stream) and arranged in the same top to bottom order presented in the summary table at Appendix A. The reader should refer to Appendix A to follow the thread of each module across the blocks.

Each module is numbered according to the Block and thread to which it is associated. For example, B0-65 indicates that this is Module 65 of Block 0. This taxonomy was used to facilitate the development of the modules but can be disregarded by the reader.

This Page Intentionally Left Blank

## **Performance Improvement Area 1: Greener Airports**

***Thread: Airport Accessibility.***

This Page Intentionally Left Blank

## Module N° B0-65: OPTIMIZATION OF APPROACH PROCEDURES INCLUDING VERTICAL GUIDANCE

<b>Summary</b>	The use of PBN and <a href="#">GLS</a> procedures will enhance the reliability and predictability of approaches to runways, thus increasing safety, accessibility and efficiency. This is possible through the application of Basic <a href="#">GNSS</a> , Baro VNAV, SBAS and GLS. The flexibility inherent in PBN approach design can be exploited to increase runway capacity.	
<b>Main Performance Impact</b>	KPA-01 Access and Equity, KPA-02 Capacity, KPA-04 Efficiency, KPA-05 Environment; KPA-10 Safety.	
<b>Operating Environment/Phases of Flight</b>	Approach	
<b>Applicability Considerations</b>	This module is applicable to all instrument, and precision instrument runway ends, and to a limited extent, non-instrument runway ends	
<b>Global Concept Component(s)</b>	AUO – Airspace User Operations AO – Aerodrome Operations	
<b>Global Plan Initiatives (GPI)</b>	GPI-5 RNAV and RNP (PBN) GPI-14 Runway Operations GPI-20 WGS84	
<b>Pre-Requisites</b>	NIL	
<b>Global Readiness Checklist</b>		<b>Status</b> (ready now or estimated date).
	Standards Readiness	
	Avionics Availability	
	Ground System Availability	
	Procedures Available	
	Operations Approvals	

### 1. Narrative

#### 1.1 General

This module complements other airspace and procedures elements (CDO, PBN and Airspace Management) to increase efficiency, safety, access and predictability.

This module describes what is available regarding approach procedures and can be more widely used now.

##### 1.1.1 Baseline

Conventional navigation aids (e.g. [ILS](#), VOR, [NDB](#)) have limitations in their ability to support the lowest minima to every runway. In the case of ILS, limitations include cost, the availability of suitable sites for ground infrastructure and an inability to support multiple descent paths. VOR and NDB procedures do not support vertical guidance and have relatively high minima that depend on siting considerations.

In the global context, GNSS-based PBN procedures have been implemented. Some States, have implemented large numbers of PBN procedures. There are several [GLS](#) procedures in place.

#### 1.2 Change brought by the module

PBN procedures require no ground-based nav aids and allow designers complete flexibility in determining the final approach lateral and vertical paths. PBN approach procedures can be seamlessly integrated with PBN arrival procedures, along with constant descent operations (CDO), thus reducing aircrew and controller workload and the probability that aircraft will not follow the expected trajectory.

States can implement GNSS-based PBN approach procedures that provide minima for aircraft equipped with basic GNSS avionics with or without Baro VNAV capability, and for aircraft equipped with SBAS avionics. GLS, which is not included in the PBN Manual, requires aerodrome infrastructure but a single station can support approaches to all runways and GLS offers the same design flexibility as PBN procedures. This flexibility provides benefits when conventional aids are out of service due to system failures or for maintenance. Regardless of the avionics fit, each aircraft will follow the same lateral path. Such approaches can be designed for runways with or without conventional approaches, thus providing benefits to PBN-capable aircraft, encouraging equipage and supporting the planning for decommissioning of some conventional aids.

The key to realizing maximum benefits from these procedures is aircraft equipage. Aircraft operators make independent decisions about equipage based on the value of incremental benefits and potential savings in fuel and other costs related to flight disruptions. Experience has shown that operators may await fleet renewal rather than equip existing aircraft.

## 2. Intended Performance Operational Improvement/Metric to determine success

**Metrics to determine the success of the module are proposed in the *Manual on Global Performance of the Air Navigation System (Doc 9883)*.**

<i>Access and Equity</i>	Increased aerodrome accessibility
<i>Capacity</i>	<u>In contrast with ILS, the GNSS-based approaches (PBN and GLS) do not require the definition and management of sensitive and critical areas, resulting in potentially increased runway capacity.</u>
<i>Efficiency</i>	Cost savings related to the benefits of lower approach minima: fewer diversions, overflights, cancellations and delays. Cost savings related to higher airport capacity in certain circumstances (e.g. closely-spaced parallels) by taking advantage of the flexibility to offset approaches and define displaced thresholds.
<i>Environment</i>	Environmental benefits through reduced fuel burn
<i>Safety</i>	Stabilized approach paths.
<u>CBA</u>	Aircraft operators and ANSPs can quantify the benefits of lower minima by using historical aerodrome weather observations and modelling airport accessibility with existing and new minima. Each aircraft operator can then assess benefits against the cost of any required avionics upgrade.

## 3. Necessary Procedures (Air & Ground)

The *Performance-based Navigation (PBN) Manual* (Doc 9613), the *Global Navigation Satellite System (GNSS) Manual* (Doc 9849), Annex 10 and [PANS-OPS](#) Volumes I and II provide guidance on system performance, procedure design and flight techniques necessary to enable [PBN](#) approach procedures. The WGS-84 Manual provides guidance on surveying and data handling requirements. The Manual on Testing of Radio Navigation Aids (Doc 8071), Volume II — Testing of Satellite-based Radio Navigation Systems provides guidance on the testing of GNSS. This testing is designed to confirm the ability of GNSS signals to support flight procedures in accordance with the standards in Annex 10. ANSPs must also assess the suitability of a procedure for publication, as detailed in [PANS-OPS](#), Volume II, Part I, Section 2, Chapter 4, Quality Assurance. The Quality Assurance Manual for Flight Procedure Design (Doc 9906), Volume 5 – Validation of Instrument Flight Procedures provides the required guidance for validation of instrument flight procedures including PBN procedures. Flight validation for PBN procedures is less costly than for conventional aids for two reasons: the aircraft used do not require complex signal measurement and recording systems; and, there is no requirement to check signals periodically.

These documents therefore provide background and implementation guidance for [ANS](#) providers, aircraft operators, airport operators and aviation regulators.

## 4. Necessary System Capability

### 4.1 Avionics

[PBN](#) approach procedures can be flown with basic [IFR](#) GNSS avionics that support on board performance monitoring and alerting (e.g. TSO C129a/C196a receivers with RAIM.); these support [LNAV](#) minima. Basic IFR GNSS receivers may be integrated with Baro VNAV functionality to support vertical guidance to LNAV/VNAV minima. In States with defined SBAS service areas, aircraft with SBAS avionics (TSO C145()/146()) can fly approaches with vertical guidance to [LPV](#) minima, which can be as low as ILS Cat I minima when flown to a precision instrument runway, and as low as 250 ft [HAT](#) when flown to an instrument runway. Within an SBAS service area, SBAS avionics can provide advisory vertical guidance when flying conventional [NDB](#) and VOR procedures, thus providing the safety benefits associated with a stabilized approach. Aircraft require TSO C161/162 avionics to fly GLS approaches. (ACTION ON Alessandro)

### 4.2 Ground Systems

SBAS-based procedures do not require any infrastructure at the airport served, but SBAS elements (e.g. reference stations, master stations, [GEO satellites](#)) must be in place such that this level of service is supported. The ionosphere is very active in equatorial regions, making it very technically challenging for the current generation of SBAS to provide vertically guided approaches in these regions. A GLS station installed at the aerodrome served can support vertically guided Cat I approaches to all runways at that aerodrome.

## 5. Human Performance

### 5.1 Human Factors Considerations

- 1.1.1 “The implementation of approach procedures with vertical guidance enables improved cockpit resource management in times of high and sometime complex workload. By allowing crew procedures to be better distributed during the conduct of the procedure, exposure to operational errors is reduced and human performance is improved. This results in clear safety benefits over procedures that lack guidance along a vertical path. Additional, some simplification and efficiencies may be achieved in crew training as well.”
- 1.1.2 Human Factors have been taken into consideration during the development of the processes and procedures associated with this module. Where automation is to be used, the Human-Machine interface has been considered from both a functional and ergonomic perspective (See Section 6 for examples). The possibility of latent failures however, continues to exist and vigilance is requested during all implementation actions. It is further requested that human factor issues, identified during implementation, be reported to the international community through ICAO as part of any safety reporting initiative

### 5.2 Training and Qualification Requirements

- 1.2 Training in the operational standards and procedures are required for this module and can be found in the links to the documents in Section 8 to this module. Likewise, the qualifications requirements are identified in the regulatory requirements in Section 6 which form an integral part to the implementation of this module.

## 6. Regulatory/standardization needs and Approval Plan (Air and Ground)

- Regulatory/Standardization: Use current published criteria that given in Section 8.4 as no new or updated regulatory guidance or standards documentation is needed at this time.
- Approval Plans: No new or updated approval criteria is needed at this time. Implementation plans should reflect available aircraft, ground systems and operational approvals.

## 7. Implementation and Demonstration Activities

### 7.1 Current Use

- United States



The United States has published over 5,000 PBN approach procedures. Of these, almost 2,500 have LNAV/VNAV and LPV minima, the latter based on WAAS (SBAS). Of the procedures with LPV minima, almost 500 have a 200 ft HAT. Current plans call for all (approximately 5,500) runways in the USA to have LPV minima by 2016. The United States has a demonstration [GLS](#) Cat I procedure at Newark; certification is pending resolution of technical and operational issues.

The United States currently has a GLS Cat I procedure in operation at Newark (KEWR) and Houston (KIAH); United States – CAT II / III working with industry to develop prototype for CAT II / III operations. Planned operational approval by 2017.

- **Canada**

Canada has published 596 PBN approach procedures with LNAV minima as of July 2011. Of these, 23 have [LNAV/VNAV](#) minima and 52 have [LPV](#) minima, the latter based on WAAS (SBAS). Canada plans to add PBN procedures, and to add LNAV/VNAV and LPV minima to those with LNAV-only minima based on demand from aircraft operators. Canada has no [GLS](#) installations.

- **Australia**

Australia has published approximately 500 PBN approach procedures with LNAV minima, and has plans to add LNAV/VNAV minima to these procedures; as of June 2011 there were 60 under development. Only about 5% of aircraft operating in Australia have Baro VNAV capability. Australia does not have SBAS, therefore none of the approaches has LPV minima. Australia has completed a [GLS](#) Cat I trial at Sydney and will be installing a new system for testing leading to full operational approval by late April 2012.

- **France**

France has published 50 PBN procedures with [LNAV](#) minima as of June 2011; 3 have LPV minima; none has LNAV/VNAV minima. The estimates for the end of 2011 are: 80 LNAV, 10 LPV and 1 LNAV/VNAV. The objective is to have PBN procedures for 100% of France's IFR runways with LNAV minima by 2016, and 100% with LPV and LNAV/VNAV minima by 2020. France has a single GLS used to support aircraft certification, but not regular operations. France has no plans for Cat I GLS.

- **Brazil**

Brazil has published 146 PBN procedures with LNAV minima as of June 2011; 45 have LNAV/VNAV minima. There are 179 procedures being developed, 171 of which will have LNAV/VNAV minima. Plans call for GLS to be implemented at main airports from 2014. Brazil does not have SBAS due in part to the challenge of providing single-frequency SBAS service in equatorial regions.

- **India**

PBN based RNAV-1 SID and STAR procedures have been implemented in six major airports. India is planning to implement 38 RNP APCH procedures with LNAV & LNAV/VNAV minima at major airport. At some airports, these approach procedures will be linked with RNP-1 STARs.

## **7.2 Planned or Ongoing Trials**

- **India**

India's SBAS system called GAGAN (GPS Aided Geo Augmented Navigation) is being developed. The certified GAGAN system will be available by June 2013 and should support the APAC region and beyond.

India has planned to implement GLS to support Satellite based Navigation in TMA, to increase accessibility to airports. The first pilot project will be undertaken in 2012 at Chennai.

## **8. Reference Documents**

### **8.1 Standards**

- ICAO Annex 10 — *Aeronautical Telecommunications*, Volume I — Radio Navigation Aids. As of 2011 a draft SARP's amendment for [GLS](#) to support Category II/III approaches is completed and is being validated by States and industry.

## **8.2 Procedures**

- ICAO Doc 8168, *Aircraft Operations*.

## **8.3 Guidance Material**

- ICAO Doc 9674, *World Geodetic System — 1984 (WGS-84) Manual*;
- ICAO Doc 9613, *Performance-based Navigation (PBN) Manual*;
- ICAO Doc 9849, *Global Navigation Satellite System (GNSS) Manual*;
- ICAO Doc 9906, *Quality Assurance Manual for Flight Procedure Design*, Volume 5 — Validation of Instrument Flight Procedures;
- ICAO Doc 8071, *Manual on Testing of Radio Navigation Aids*, Volume II — Testing of Satellite-based Radio Navigation Systems;
- ICAO Doc 9931, *Continuous Descent Operations (CDO) Manual*.

## **8.4 Approval Documents**

- FAA AC 20-138(), TSO-C129/145/146()
- ICAO Doc 4444, *Procedures for Air Navigation Services — Air Traffic Management*;
- ICAO Flight Plan Classification;
- ICAO Doc 8168, *Aircraft Operations*;
- ICAO Doc 9613, *Performance Based Navigation Manual*;
- ICAO Annex 10 — *Aeronautical Telecommunications*;
- ICAO Annex 11 — *Air Traffic Services*;
- ICAO Doc 9674, *World Geodetic System — 1984 (WGS-84) Manual*.

This Page Intentionally Left Blank

## Module N° B1-65: Optimized Airport Accessibility

<b>Summary</b>	To progress further with the universal implementation of <a href="#">PBN</a> approaches. PBN and <a href="#">GLS</a> (CAT II/III) procedures enhance the reliability and predictability of approaches to runways increasing safety, accessibility and efficiency.	
<b>Main Performance Impact</b>	KPA-04 Efficiency, KPA-05 Environment, KPA-10 Safety,	
<b>Operating Environment/Phases of Flight</b>	Approach and landing	
<b>Applicability Considerations</b>	This module is applicable to all runway ends.	
<b>Global Concept Component(s)</b>	AUO – Airspace User Operations AO – Aerodrome Operations	
<b>Global Plan Initiatives (GPI)</b>	GPI-5 RNAV and <a href="#">RNP</a> (PBN) GPI-14 Runway Operations GPI-20 WGS84	
<b>Pre-Requisites</b>	B0-65	
<b>Global Readiness Checklist</b>		<b>Status</b> (ready now or estimated date).
	Standards Readiness	Est. 2014
	Avionics Availability	Est. 2018
	Ground System Availability	√
	Procedures Available	√
	Operations Approvals	Est. 2018

### 1. Narrative

#### 1.1 General

This module complements other airspace and procedures elements (CDO, PBN and Airspace Management) to increase efficiency, safety, access and predictability.

##### 1.1.1 Baseline

Module B0-65 provided the first step toward universal implementation of GNSS-based approaches. It is likely that many States will have a significant number of GNSS-based PBN approaches, and in some States virtually all runways will be served by PBN procedures. Where GLS and/or SBAS are available, precision instrument runways will have Cat I minima.

##### 1.1.2 Change brought by the module

This module proposes to take advantage of the lowest available minima through the extension of GNSS-based approaches from CAT-I capability to category CAT II/III capability at a limited number of airports. It also harnesses the potential integration of the PBN STARS directly to all approaches with vertical guidance. This capability allows for both curved approaches and segmented approaches in an integrated system. The emergence of multi-frequency/constellation GNSS may start to be developed to enhance approach procedures.

As more PBN and GLS procedures become available, and as more aircraft are equipped with the required avionics, application of this module will result in some rationalisation of the navigation infrastructure.

Increased aerodrome accessibility via lower approach minima to more runways will be reflected in fewer flight disruptions, reduced fuel burn and reduced greenhouse gas emissions. The more widespread availability of SBAS and [GLS](#) procedures will enhance safety via vertical guidance.

## 2. Intended Performance Operational Improvement

Metrics to determine the success of the module are proposed in the *Manual on Global Performance of the Air Navigation System (Doc 9883)*.

<i>Efficiency</i>	Cost savings related to the benefits of lower approach minima: fewer diversions, overflights, cancellations and delays. Cost savings related to higher airport capacity by taking advantage of the flexibility to offset approaches and define displaced thresholds.
<i>Environment</i>	Environmental benefits through reduced fuel burn
<i>Safety</i>	Stabilized approach paths.
<a href="#">CBA</a>	Aircraft operators and ANSPs can quantify the benefits of lower minima by modelling airport accessibility with existing and new minima. Operators can then assess benefits against avionics and other costs. The <a href="#">GLS</a> Cat II/III business case needs to consider the cost of retaining <a href="#">ILS</a> or <a href="#">MLS</a> to allow continued operations during an interference event. The potential for increased runway capacity benefits with GLS is complicated at airports where a significant proportion of aircraft are not equipped with GLS avionics.

## 3. Necessary Procedures (Air & Ground)

New criteria for Instrument Flight Procedures will need to be developed for GLS Cat II/III to become operational.

## 4. Necessary System Capability

### 4.1 Avionics

Module B0-65 describes the avionics required to fly PBN approach procedures, and explains the requirements for, benefits and limitations of SBAS based on single-frequency GPS. It is expected that standards will exist for Cat II/III GLS in 2018, that some ground stations will be in place in some States and that there may be avionics available to support Cat II/III GLS operationally. There will likely be some expansion of operational Cat I GLS operations in some States.

The majority of operations globally will continue to be based on single-frequency GPS, although in some regions (e.g. Russia) avionics will integrate GLONASS and GPS signals. It is expected that GPS will provide signals on two frequencies for civilian use by 2018, and there are similar plans for GLONASS. It is possible that the emerging core constellations Galileo and Compass/Beidou will be operational in 2018 and that these constellations will be standardized in Annex 10; both are designed to be interoperable with GPS and will also provide service on two civilian frequencies. The availability of avionics and the extent of operational use of multi-constellation, multi-frequency GNSS will be determined by incremental benefits; it is not certain that there will be standards for such avionics by 2018. The availability of multiple frequencies could be exploited to eliminate ionospheric errors and support a simplified SBAS that could provide approaches with vertical guidance. The availability of multi-constellation GNSS offers robustness in the presence of severe ionospheric disturbances and could allow expansion of SBAS to equatorial regions. It not expected multiple frequencies and constellations will exploited to any degree globally in 2018

### 4.2 Ground Systems

Cat II/III GLS Ground Stations.

## 5. Human Performance

### 5.1 Human Factors Considerations

**5.1.1** The integration of PBN with GLS for flight operations presents a number of possible issues for human performance. The effects of crew operations and procedures will be dictated by the means integration of capability in the aircraft avionics e.g. if the aircraft avionics simply has a mode transition from a RNP system flying the PBN procedure to a GLS system flying the GLS procedure, what is required for crew monitoring, action or procedures could be substantially different than a system where the transition is managed internally by the avionics leaving the crew to monitor operational conformance. The difference in human performance could be the difference from what essentially exists today to one with reduction in total workload but a difference from other operations. These need to be considered in assessing human performance.

**5.1.2** The identification of Human Factors considerations is an important enabler in identifying processes and procedures for this module. In particular, the human-machine interface for the automation aspects of this performance improvement will need to be considered and where necessary accompanied by mitigation risk mitigation strategies such as training, education and redundancy.

### 5.2 Training and Qualification Requirements

**5.2.1** Training in the operational standards and procedures will be identified along with the standards and recommended practices necessary for this module to be implemented. Likewise the qualifications requirements will be identified and included in the regulatory readiness aspects of this module when they become available.

## 6. Regulatory/standardization needs and Approval Plan (Air and Ground)

- Regulatory/Standardization: Updates to published criteria given in Section 8.4;
- Approval Plans: Updated approval criteria is needed for Cat II/III GLS at this time. Implementation plans should reflect available aircraft, ground systems and operational approvals.

## 7. Implementation and Demonstration Activities

### 7.1 Current Use

### 7.2 Planned or Ongoing Activities

- **United States** - By 2016 all runways (approximately 5,500) in the United States will be served by PBN procedures with LNAV, LNAV/VNAV and LPV minima. Precision instrument runways will likely all have 200 ft [HAT](#) LPV minima based on WAAS (SBAS). CAT II / III working with industry to develop prototype for CAT II / III operations. Planned operational approval by 2017.
- **Canada** - By 2018 Canada expects to expand PBN approach service based on demand from aircraft operators. As of 2011 Canada does not have plans to implement GLS.
- **SESAR** - Cat II/III GLS flight trials planned in 2014. RNP to GLS transition validation planned in 2014
- **Australia** - By 2018 Australia expects a considerable expansion of PBN approach service. Subject to the successful introduction of the CAT 1 GLS service into Sydney. Airservices will further validate GLS operational benefits in consultation with key airline customers with a view to expanding the network beyond Sydney in the period 2013 to 2018. Other activities to be considered in relation to the expansion and development of the GLS capability in Australia include development of a CAT II/III capability during the three years following 2011.
- **France** - The objective is to have PBN procedures for 100% of France's [IFR](#) runways with LNAV minima by 2016, and 100% with LPV and LNAV/VNAV minima by 2020. France has no plans for Cat I GLS and it is unlikely that there will be Cat II/III GLS in France by 2018 because there is not a clear business case.

- **Brazil** - By 2018 Brazil expects a considerable expansion of PBN procedures. Plans call for GLS to be implemented at main airports from 2014.

## **8. Reference Documents**

### **8.1 Standards**

- ICAO Annex 10 — *Aeronautical Telecommunications*.

### **8.2 Procedures**

- ICAO Doc 4444, *Procedures for Air Navigation Services — Air Traffic Management*.

### **8.3 Guidance Material**

- ICAO Doc 8071, *Manual on Testing of Radio Navigation Aids, Volume II — Testing of Satellite-based Radio Navigation Systems*;
- ICAO Doc 9613, *Performance-based Navigation (PBN) Manual*;
- ICAO Doc 9674, *World Geodetic System — 1984 (WGS-84) Manual*;
- ICAO Doc 9849, *Global Navigation Satellite System (GNSS) Manual*;
- ICAO Doc 9906, *Quality Assurance Manual for Flight Procedure Design, Volume 5 — Validation of Instrument Flight Procedures*.

### **8.4 Approval Documents**

- ICAO Doc 4444, *Procedures for Air Navigation Services — Air Traffic Management*;
- ICAO Doc 9613, *Performance Based Navigation Manual*;
- ICAO Annex 10 — *Aeronautical Telecommunications*;
- ICAO Annex 11 — *Air Traffic Services*;
- FAA AC 20-138(), TSO-C129/145/146()

This Page Intentionally Left Blank



## **Performance Improvement Area 1: Greener Airports**

***Thread: Wake Turbulence Separation.***

This Page Intentionally Left Blank

## Module N° B0-70: Increased Runway Throughput through Wake Turbulence Separation

<b>Summary</b>	Improved throughput on departure and arrival runways through the revision of current ICAO wake turbulence separation minima and procedures.	
<b>Main Performance Impact</b>	KPA-02 – Capacity, KPA-06 Flexibility	
<b>Operating Environment / Flight Phases</b>	Arrival and Departure	
<b>Applicability Considerations</b>	Least Complex – Implementation of re-categorized wake turbulence is mainly procedural. No changes to automation systems are needed.	
<b>Global Concept Component(s)</b>	CM – Conflict Management	
<b>Global Plan Initiatives (GPI)</b>	GPI-13- Aerodrome Design; GPI 14 – Runway Operations	
<b>Main Dependencies</b>	Nil	
<b>Global Readiness Checklist</b>		<b>Status</b> (ready now or estimated date)
	Standards Readiness	<b>2013</b>
	Avionics Availability	<b>N/A</b>
	Ground Systems Availability	<b>N/A</b>
	Procedures Available	<b>2013</b>
	Operations Approvals	<b>2013</b>

### 1. Narrative

#### 1.1 General

Refinement of the Air Navigation Service Provider (ANSP) aircraft-to-aircraft wake mitigation processes, procedures and standards will allow increased runway capacity with the same or increased level of safety. This upgrade is being accomplished without any changes to aircraft equipage or changes to aircraft performance requirements. The upgrade contains three elements that have been, or will be implemented by the end of 2013 at selected aerodromes. Element 1 is the revision of the current ICAO wake separation minima to allow more capacity efficient use of aerodrome runways without an increase in risk associated with a wake encounter. Element 2 is increasing, at some aerodromes, the number of arrival operations on closely spaced (runway centre lines spaced closer than 2500 feet apart) parallel runways (CSPR) by modifying how wake separations are applied by the ANSP. Element 3 is increasing, at some aerodromes, the number of departure operations on parallel runways by modifying how wake separations are applied by the ANSP.

#### 1.1.1 Baseline

ANSP applied wake mitigation procedures and associated standards were developed over time, with the last comprehensive review occurring in the early 1990's. These 1990's standards are inherently conservative, in terms of required aircraft-to-aircraft wake separations, to account for inaccuracies in the then existing aircraft wake turbulence transport and decay models and lack of extensive collected data on aircraft wake behaviour.

#### 1.1.2 Change brought by the module

This Module will result in a change to the applied wake mitigation procedures of an ANSP. Based on the standards developed, safely modifies the separation minima and their application by ANSPs to allow

incremental increases to aerodrome runway throughput capacity. The capacity gains by Element 1 (changing wake separation minima) is predicted to be 4% for European capacity constrained aerodromes, 7% for U.S. capacity constrained aerodromes with similar gains in other capacity constrained aerodromes worldwide. Elements 2 (increasing aerodrome arrival operational capacity) and 3 (increasing departure operational capacity) provide runway capacity improvements to aerodromes having runway configurations and aircraft traffic mixes that allow specialized [ANSP](#) wake mitigation procedures to enhance the runway throughput capacity. The aerodrome specific specialized procedures have/will result in increased aerodrome arrival capacity (5 to 10 more operations per hour) during instrument landing operations or increased aerodrome departure capacity (2 to 4 more operations per hour).

### **1.2 Element 1: Revision of the Current ICAO Wake Separation Minima**

The last full review of wake separation minima used by air traffic control occurred nearly 20 years ago in the early 1990's. Since then, air carrier operations and fleet mix have changed dramatically, aerodrome runway complexes have changed and new aircraft designs (A-380, Boeing 747-8, very light jets, unmanned aircraft systems) have been introduced into the [NAS](#). The twenty-year old wake separation minima still provides safe separation of aircraft from each other's wakes but it no longer provides the most capacity efficient spacing and sequencing of aircraft in approach and en-route operations. This loss of efficient spacing is adding to the gap between demand and the capacity the commercial aviation infrastructure can provide.

The work in Element 1 is being accomplished by a joint EUROCONTROL and FAA working group that has reviewed the current required wake mitigation aircraft separations used in both the USA's and Europe's air traffic control processes and has determined the current standards can be safely modified to increase the operational capacity of aerodromes and airspace. In 2010, the working group provided a set of recommendations for ICAO review that focused on changes to the present set of ICAO wake separation minima. To accomplish this, the workgroup developed enhanced analysis tools to link observed wake behaviour to standards and determined safety risk associated with potential new standards relative to existing standards. ICAO, after receiving the ICAO recommendations, formed the Wake Turbulence Study Group to review the FAA/EUROCONTROL working group recommendations along with other recommendations received from ICAO member states. It is expected that by the end of 2012, ICAO will publish wake separation standard changes to its Procedures for Air Navigation Services.

### **1.3 Element 2: Increasing Aerodrome Arrival Operational Capacity**

ANSP wake mitigation procedures applied to instrument landing operations on [CSPR](#) are designed to protect aircraft for a very wide range of aerodrome parallel runway configurations. Prior to 2008, instrument landing operations conducted to an aerodrome's CSPR had to have the wake separation spacing equivalent to conducting instrument landing operations to a single runway. When an aerodrome using its CSPR for arrival operations had to shift its operations from visual landing procedures to instrument landing procedures, it essentially lost one half of its landing capacity (i.e. from 60 to 30 landing operations per hour).

Extensive wake transport data collection efforts and the resulting analyses indicated that the wakes from aircraft lighter than Boeing 757 and heavier aircraft travelled less than previously thought. Based on this knowledge, high capacity demand aerodromes in the U.S. that used their CSPR for approach operations were studied to see if instrument approach procedures could be developed that provide more landing operations per hour than the single runway rate. A dependent diagonal paired instrument approach procedure (FAA Order 7110.308) was developed and made available for operational use in 2008 for five aerodromes that had CSPR configurations that met the runway layout criteria of the developed procedure. Use of the procedure provided an increase of up to 10 more arrival operations per hour on the aerodrome CSPR. By the end of 2010 the approval to use the procedure was expanded to two additional aerodromes. Work is continuing to develop variations of the procedure that will allow its application to more aerodromes' CSPRs with fewer constraints on the type of aircraft that must be the lead aircraft of the paired diagonal dependent approach aircraft.

### **1.4 Element 3: Increasing Aerodrome Departure Operational Capacity**

Element 3 is the development of enhanced wake mitigation [ANSP](#) departure procedures that safely allow increased departure capacity on aerodrome CSPR. Procedures being developed are aerodrome specific in terms of runway layout weather conditions. The Wake Independent Departure and Arrival Operation (WIDAO) developed for use on CSPR at Charles de Gaulle aerodrome was developed as a result of an extensive wake turbulence transport measurement campaign at the aerodrome. WIDAO implementation allows the ANSP to use the inner CSPR for departures independent of the arrivals on the outer CSPR where

before the [ANSP](#) was required to apply a wake mitigation separation between the landing aircraft on the outer CSPR and the aircraft departing on the inner CSPR. Wake Turbulence Mitigation for Departures (WTMD) is a development project by the U.S. that will allow, when runway crosswinds are of sufficient strength and persistence, aircraft to depart on the up wind CSPR after a Boeing 757 or heavier aircraft departs on the downwind runway – without waiting the current required wake mitigation delay of 2 to 3 minutes. WTMD applies a runway cross wind forecast and monitors the current runway crosswind to determine when the WTMD will provide guidance to the controller that the 2 to 3 minute wake mitigation delay can be eliminated and when the delay must again be applied. WTMD is being developed for implementation at 8 to 10 U.S. aerodromes that have CSPR with frequent favourable crosswinds and a significant amount of Boeing 757 and heavier aircraft operations. Operational use of WTMD is expected in spring 2011.

## 2. Intended Performance Operational Improvement

**Metrics to determine the success of the module are proposed in the *Manual on Global Performance of the Air Navigation System (Doc 9883)*.**

<i>Capacity</i>	<ul style="list-style-type: none"> <li>a. Aerodrome capacity and departure/arrival rates will increase as the wake categories are increased from 3 to 6.</li> <li>b. Aerodrome capacity and arrival rates will increase as specialized and tailored <a href="#">CSPR</a> procedures for instrument landing operations are developed and implemented in more aerodromes. Current instrument landing procedures reduce aerodrome throughput by 50%.</li> <li>c. New procedures will modify the current wake mitigation measures of waiting for 2-3 minutes, and decrease the waiting time required. Aerodrome capacity and departure rates will increase. In addition, runway occupancy time will decrease as a result of this new procedure.</li> </ul>
<i>Flexibility</i>	<a href="#">ANSP</a> have the choice to configure the aerodrome to operate on 3 or 6 categories, depending on demand.

<a href="#">CBA</a>	<p>Benefits of this Module are to the users of the aerodrome’s runways. Overly safety conservative ANSP wake separation procedures and associated separation minima do not allow the maximum utility of an aerodrome’s runway. Air carrier data shows when operating from a major hub operation at a U.S. aerodrome, a gain of two extra departures per hour from the aerodrome’s <a href="#">CSPR</a> during the “rush” has a major beneficial effect in reducing delays in the air carrier’s operations.</p> <p>The ANSP may need to develop tools to assist controllers with the additional wake categories and WTMD decision support tools. The tools necessary will depend on the operation at each airport and the number of wake categories implemented.</p>
---------------------	---

## 3. Necessary Procedures (Air & Ground)

The change to the ICAO wake turbulence separation minima will involve increasing the number of ICAO wake turbulence aircraft categories from three to six categories along with the assignment of aircraft types to each of the six wake turbulence categories. It is likely that the ANSP procedures, using the full six categories, will need some automation support in providing the wake turbulence category assignment of an aircraft to the controller, so the controller will know which wake turbulence separation to apply between aircraft. Implementing Element 1 will not require any changes to air crew flight procedures. However, there will be changes required in how a flight plan is filed in terms of the aircraft’s wake turbulence category.

The module implementations impacting the use of an aerodrome’s [CSPR](#) for arrivals, only affect the ANSP procedures for sequencing and segregating aircraft to the CSPR. Element 2 products are additional procedures for use by the [ANSP](#) for situations when the aerodrome is operating instrument flight rules and there is a need to land more flights than can be achieved by using only one of its CSPR. The procedures implemented by Element 2 require no changes to the aircrew’s procedures for accomplishing an instrument landing approach to the aerodrome.

Module Element 3 implementations only affect the [ANSP](#) procedures for departing aircraft on an aerodrome’s CSPR. Element 3 products are additional procedures for use by the ANSP for situations when

the aerodrome is operating under a heavy departure demand load and the aerodrome will be having a significant number of Boeing 757 and heavier aircraft in the operational mix. The procedures provide for transitioning to and from reduced required separations between aircraft and criteria for when the reduced separations should not be used. The procedures implemented by Element 3 require no changes to the aircrew's procedures for accomplishing a departure from the aerodrome. When a specialized [CSPR](#) departure procedure is being used at an aerodrome, pilots are notified that the special procedure is in use and that they can expect a more immediate departure clearance.

## **4. Necessary System Capability**

### **4.1 Avionics**

No additional technology for the aircraft or additional aircrew certifications is required.

### **4.2 Ground Systems**

Some ANSPs may develop a decision support tool to aid in the application of the new set of 6 category ICAO wake separates. The Element 2 and Element 3 products vary on their dependency to newly applied technology. The WTMD implementation requires wind sensors and automation to predict crosswind strength and direction and to display that information to the ANSP controllers and supervisors.

## **5. Human Performance**

### **5.1 Human Factors Considerations**

**5.1.2** Human Factors have been taken into consideration during the development of the processes and procedures associated with this module. Where automation is to be used, the Human-Machine interface has been considered from both a functional and ergonomic perspective (See Section 6 for examples). The possibility of latent failures however, continues to exist and vigilance is requested during all implementation actions. It is further requested that human factor issues, identified during implementation, be reported to the international community through ICAO as part of any safety reporting initiative.

### **5.2 Training and Qualification Requirements**

**5.2.2** Controllers will require training on additional wake categories and separation matrix. The addition of Element 3, WTMD, will require training for controllers on the use of the new tools to monitor and predict cross-winds.

**5.2.3** Training in the operational standards and procedures are required for this module and can be found in the links to the documents in Section 8 to this module. Likewise, the qualifications requirements are identified in the regulatory requirements in Section 6 which form an integral part to the implementation of this module.

## **6. Regulatory/standardization needs and Approval Plan (Air & Ground)**

Regulatory/Standardization: Updates required to current published criteria given in Section 8.4.

Approval Plans: To Be Determined following updates to standards. Note: Existing interim activities including those associated with FAA Order 7110.308, FAA Wake Turbulence Mitigation for Departures (WTMD), and Wake Independent Departure and Arrival Operation (WIDAO) criteria in use at [CDG](#) will continue and are expected to be included in the ICAO revised material.

## **7. Implementation and Demonstration Activities**

### **7.1 Current Use**

#### **7.1.2 Revised Wake Turbulence Separation Minima**

- None at this time. Awaiting the ICAO approval of the revised wake turbulence separation minima, expected in 2012/13.

#### **7.1.3 Increasing Aerodrome Arrival Operational Capacity**

- **United States** - The FAA Order 7110.308 procedure use has been approved for seven U.S. aerodromes with Seattle-Tacoma (KSEA) and Memphis (KMEM) aerodromes using the procedure during runway maintenance closures. Use at Cleveland (KCLE) is awaiting runway instrumentation changes.

#### 7.1.4 Increasing Aerodrome Departure Operational Capacity

- **France** - The Wake Independent Departure and Arrival Operation (WIDAO) relaxation of wake separation constraints at Charles de Gaulle (LFPG) (first and second sets of constraints) were approved in November 2008 and March 2009. The final set of LFPG constraints was lifted in 2010.
- **United States** – Wake Turbulence Mitigation for Departures (WTMD) is currently at two sites, KIAH and KMEM.

### 7.2 *Planned or Ongoing Trials*

#### 7.2.2 Revised Wake Turbulence Separation Minima

- **United States** – Concurrent with the ICAO approval process, the FAA is developing documentation and adapting its automation systems to allow implementation of the wake separation standard. The ICAO approval is expected in 2013.

#### 7.2.3 Increasing Aerodrome Arrival Operational Capacity

- **United States** – Work is continuing to develop variations of the FAA Order 7110.308 procedure that will allow its application to more aerodrome's [CSPR](#) with fewer constraints on the type of aircraft that must be the lead aircraft of the paired diagonal dependent approach aircraft. It is expected that by the end of 2012, the procedure will be available in the US for use by an additional six or more CSPR aerodromes during periods when they use instrument approach landing procedures. **Additional continuation of sites will be added.**

#### 7.2.4 Increasing Aerodrome Departure Operational Capacity

- **United States** - Wake Turbulence Mitigation for Departures (WTMD) is a development project by the U.S. that will allow, when runway crosswinds are of sufficient strength and persistence, aircraft to depart on the up wind CSPR after a Boeing 757 or heavier aircraft departs on the downwind runway – without waiting the current required wake mitigation delay of two to three minutes. WTMD is being developed for implementation at eight to ten U.S. aerodromes that have CSPR with frequent favourable crosswinds and a significant amount of Boeing 757 and heavier aircraft operations. WTMD demonstrations at KSFO are currently planned for 2013. Six additional aerodromes will be identified in the future.

## 8. Reference Documents

### 8.1 *Standards*

### 8.2 *Procedures*

### 8.3 *Guidance Materials*

### 8.4 *Approval Documents*

- ICAO Doc 4444, *Procedures for Air Navigation Services — Air Traffic Management*;
- ICAO Doc 9426, *Air Traffic Services Planning Manual*;
- FAA Order 7110.308.

## Module N° B1-70: Increased Runway Throughput through Dynamic Wake Turbulence Separation

<b>Summary</b>	Improved throughput on departure and arrival runways through the dynamic management of wake turbulence separation minima based on the real-time identification of wake turbulence hazards.	
<b>Main Performance Impact</b>	KPA-02 Capacity, KPA-04 Efficiency, KPA-05 Environment, KPA-06 Flexibility.	
<b>Operating Environment / Flight Phases</b>	Aerodrome	
<b>Applicability Considerations</b>	Least Complex – Implementation of re-categorized wake turbulence is mainly procedural. No changes to automation systems are needed.	
<b>Global Concept Component(s)</b>	CM - Conflict Management	
<b>Global Plan Initiatives (GPI)</b>	GPI-13- Aerodrome Design; GPI 14 – Runway Operations	
<b>Main Dependencies</b>	B0-70	
<b>Global Readiness Checklist</b>		<b>Status (ready or date)</b>
	Standards Readiness	Est. 2018
	Avionics Availability	N/A
	Ground System Availability	Est. 2018
	Procedures Available	Est. 2018
	Operations Approvals	Est. 2018

### 1. Narrative

#### 1.1 General

Refinement of the Air Navigation Service Provider (ANSP) aircraft-to-aircraft wake mitigation processes, procedures and standards will allow increased runway capacity with the same or increased level of safety. Block 1 upgrade will be accomplished without any required changes to aircraft equipage or changes to aircraft performance requirements. Full benefit from the upgrade would require significantly more aircraft/crews being able to conduct RNP based approaches and aircraft broadcasting their aircraft based weather observations during their airport approach and departure operations. The upgrade contains three elements that will be implemented by ANSP by the end of 2018. Element 1 is the establishment of wake turbulence mitigation separation minima based on the wake generation and wake upset tolerance of individual aircraft types rather than ICAO standards based on 6 broad categories of aircraft. Element 2 is increasing, at some airports, the number of arrival operations on closely spaced (runway centre lines spaced closer than 2500 feet apart) parallel runways (CSPR) and on single runways taking into account the winds present along the approach corridor in modifying how wake separations are applied by the ANSP. Element 3 is increasing, at selected additional airports, the number of departure operations on parallel runways by modifying how wake separations are applied by the ANSP.

##### 1.1.1 Baseline

ANSP applied wake mitigation procedures and associated standards were developed over time, with the last comprehensive review occurring from 2008 to 2012, resulting in the ICAO approved 6 category wake turbulence separation minima. The new ICAO Standards (2013) allow greater runway utilization than the earlier wake separation minima, however the new standards can be enhanced to define safe runway capacity and efficient wake turbulence separations for typical aircraft operating at an airport. By the end of 2013, some airports were approved to use modified ANSP wake separation procedures on their CSPR, if



certain runway layout and instrumentation criteria were met. Also by the end of 2013, some airports will be using [ANSP](#) wake separation CSPR departure procedures based on predicted and monitored crosswinds.

### **1.1.2 Change brought by the module**

This Module (B1–70) represents an expansion on the wake separation minima and ANSP wake mitigation procedures upgrade accomplished in Block 0. Block 1 represents technology being applied to make available further runway capacity savings by enhancing the efficiency of wake turbulence separation minima and the ease by which they can be applied by the ANSP. Element 1's expansion of the 6 category wake separation minima to a Leader/Follower - Pair Wise Static matrix of aircraft type wake separation pairings (potentially 64 or more separate pairings), is expected to yield an average increased airport capacity of 4% above that which was obtained by the Block 0 upgrade to the ICAO 6 category wake separation minima. Element 2 expands the use of specialized ANSP wake mitigation separation procedures to more airports by using airport wind information (predicted and monitored) to adjust the needed wake mitigation separations between aircraft on approach. Element 3 uses the same wind prediction/monitoring technology as Element 2 and will allow greater number of airports to increase their departure runway operations if airport winds are favourable. The estimated capacity gains by Element 1 (changing to Leader/Follower - Pair Wise Static wake separations) will be for European, U.S. and other capacity constrained airports world-wide. Elements 2 (increasing airport arrival operational capacity) and 3 (increasing departure operational capacity) provide runway capacity improvements to a wider range of airports than the upgrades of Block 0 could deliver. These Element 2 and 3 technology aided airport specific specialized procedures will provide for additional airports increased airport arrival capacity (5 to 10 more operations per hour) during instrument landing operations and increased airport departure capacity (2 to 4 more operations per hour) during favourable airport wind conditions.

### **1.1.3 Other Remarks**

The work accomplished in Block 1 builds on the upgrades of Block 0 and will be the basis for further enhancement in wake mitigation procedures and standards that will occur in Block 2 developments. The Wake Turbulence Separation - Refined Module is a progression of steps to have available to global aviation, means to acquire more capacity from existing airport runway structure and to place new airport runways for minimizing wake turbulence landing and departure restrictions. The effort in Block 1 will not provide the major capacity increases needed to meet the overall demand envisioned for the 2025 time frame. However it does provide incremental capacity increases using today's runways and minor modifications to air traffic control procedures. Block 1 and subsequent Block 2 will address developing wake mitigation procedures and separation minima that will assure the wake safety of innovations (Trajectory Based, High Density, Intended Performance Operational Improvement/Metric to determine success. Flexible Terminal) in air traffic control while at the same time provide the least wake safety constraints on the air traffic control innovation. The upgrades of block 1 will incorporate the experience obtained with the Block 0 upgrades.

## ***1.2 Element 1: Implement Leader/Follower - Pair Wise Static Matrix Wake Separation Minima***

The work in Element 1 is being accomplished by a joint EUROCONTROL and FAA working group that in Block 0 reviewed the wake turbulence mitigation aircraft separations used in both the USA's and Europe's air traffic control processes and determined the standards can be safely modified to increase the operational capacity of airports and airspace. A 6 category wake turbulence separation recommendation was developed by the working group and provided to ICAO. It is expected that by the end of 2012, ICAO will publish the recommendation as changes to its Procedures for Air Navigation Services.

Block 1 Element 1 work will again be accomplished by the joint EUROCONTROL and FAA working group. It will take the analysis tools developed for its 6 category wake turbulence separation standard recommendation and enhance them to investigate the added airport capacity that could be obtained if wake separations were tailored to the performance characteristics of the aircraft generating the wake turbulence and the performance characteristics of the aircraft that might encounter the generated wake turbulence. Preliminary estimates have indicated that an additional 3 to 5% increase to airport capacity could be obtained from this more complex Leader/Follower - Pair Wise Static matrix of aircraft type wake separation pairings. Depending on the majority of aircraft types operating at an airport, the ANSP would use the associated paired wake turbulence separation minima for operations involving those aircraft types. For all other aircraft types, a more general wake turbulence separation would be applied. It is planned that the Leader/Follower - Pair Wise Static Matrix wake turbulence separation minima recommendation will be

provided to ICAO at the end of 2014 and ICAO will approve ANSP use of the matrix in 2016. Modifications to the ANSP [ATC](#) systems will likely be required to support effective use of the Leader/Follower - Pair Wise Static Matrix wake turbulence separation minima.

### **1.3 Element 2: Increasing Airport Arrival Operational Capacity at Additional Airports for [CSPR](#)**

ANSP wake mitigation procedures applied to instrument landing operations on CSPR are designed to protect aircraft for a very wide range of airport parallel runway configurations. Prior to 2008, instrument landing operations conducted to an airport's CSPR had to have the wake separation spacing equivalent to conducting instrument landing operations to a single runway. When an airport using its CSPR for arrival operations had to shift its operations from visual landing procedures to instrument landing procedures, it essentially lost one half of its landing capacity (i.e. from 60 to 30 landing operations per hour).

Block 0 Element 2 upgrade provided a dependent diagonal paired instrument approach wake separation procedure (FAA Order 7110.308) for operational use in 2008 at five airports that had CSPR configurations meeting the runway layout criteria of the developed procedure. Use of the procedure provided an increase of up to 10 more arrival operations per hour on the airport CSPR during airport operations requiring instrument approaches. By the end of 2010 the approval to use the procedure was expanded to two additional airports. An enhanced version of FAA Order 7110.308 will be approved in 2012 for use by up to six more U.S. airports who use their CSPR for arrival operations.

Block 1 work will expand the use of the dependent instrument landing approach procedure to capacity constrained airports that use their CSPR for arrival operations but do not have the runway configuration to satisfy the constraints of FAA Order 7110.308. The mechanism for this expansion is the Wake Turbulence Mitigation for Arrivals (WTMA) capability that will be added to FAA ATC systems. WTMA relies on predicted and monitored winds along the airport approach path to determine if wakes of arriving aircraft will be prevented by cross winds from moving into the path of aircraft following on the adjacent CSPR. The WTMA capability maybe expanded during Block 1 to include predicting when steady crosswinds would blow wakes out of the way of aircraft following directly behind the generating aircraft – allowing the ANSP to safely reduce the wake separation between aircraft approaching a single runway. It is expected that by the end of 2018, the WTMA capability will be in use at an additional six or more CSPR airports whose physical layout precluded use of the non-wind dependent 7110.308 Block 0 developed procedures.

A critical component of the WTMA capability is wind information along the airport's approach corridor. The use of WTMA will be limited by the timely availability of this information. During Block 1 time frame, it is expected that aircraft wind information observed and transmitted during their approach to the airport will be incorporated into the WTMA wind prediction model as a replacement for the much more latten National Weather Service forecasted winds information. The use of aircraft wind data will significantly increase WTMA's capability to forecast and monitor wind changes, allowing WTMA wake separations to used during times when before, due to uncertainty of wind information, use of the reduced wake separations was precluded.

### **1.4 Element 3: Increasing Airport Departure Operational Capacity at Additional Airports**

Element 3 is the development of technology aided enhanced wake turbulence mitigation ANSP departure procedures that safely allow increased departure capacity on an airport's CSPR.

Wake Turbulence Mitigation for Departures (WTMD) is a development project by the U.S. that allows, when runway crosswinds are of sufficient strength and persistence, aircraft to depart on the up wind CSPR after a Boeing 757 or heavier aircraft departs on the downwind runway – without waiting the current required wake mitigation delay of 2 to 3 minutes. WTMD applies a runway cross wind forecast and monitors the current runway crosswind to determine when the WTMD will provide guidance to the controller that the 2 to 3 minute wake mitigation delay can be eliminated and when the delay must again be applied. WTMD was developed for implementation at eight to ten U.S. airports that have CSPR with frequent favourable crosswinds and a significant amount of Boeing 757 and heavier aircraft operations. Operational use of WTMD began in 2011.

Block 1 will enhance the WTMD capability to predict when crosswinds will be sufficient to prevent the wake

of a departing aircraft from transporting into the path of an aircraft departing on the adjacent CSPR. WTMD will be modified to receive and process aircraft wind information observed during their departure from the airport, as a replacement for the much more latten National Weather Service forecasted winds information. Use of aircraft wind data will significantly increase WTMD’s capability to forecast and monitor wind changes, allowing WTMD wake separations to used during times when before, due to uncertainty of wind information, use of the reduced wake separations was precluded.

**2. Intended Performance Operational Improvement**

**Metrics to determine the success of the module are proposed in the *Manual on Global Performance of the Air Navigation System (Doc 9883)*.**

<i>Capacity</i>	<b>Element 1</b> Better wind information around the aerodrome to enact reduced wake mitigation measures in a timely manner. Aerodrome capacity and arrival rates will increase as the result of reduced wake mitigation measures.
<i>Flexibility</i>	<b>Element 2</b> Dynamic Scheduling. ANSPs have the choice of optimizing the arrival/departure schedule via pairing number of unstable approaches.
<i>Efficiency/Environment</i>	<b>Element 3</b> Changes brought by this element will enable more accurate crosswind prediction.

<a href="#"><u>CBA</u></a>	<p>Element 1’s change to the ICAO wake separation minima will yield an average 4% additional capacity increase for an airport’s runways in Europe, U.S, and other airports world-wide. The 4% increase translates to 1 more landing per hour for a single runway that normally could handle 30 landings per hour. One extra slot per hour creates revenue for the air carrier that fills them and for the airport that handles the extra aircraft operations and passengers.</p> <p>The impact of the Element 2 upgrade is the reduced time that an airport, due to weather conditions, must operate its <a href="#"><u>CSPR</u></a> as a single runway. Element 2 upgrade allows more airports to better utilize their CSPR when they are conducting instrument flight rules operations – resulting in 8 to 10 more airport arrivals per hour when crosswinds are favourable for WTMA reduced wake separations. For the Element 2 upgrade, the addition of a crosswind prediction and monitoring capability to the <a href="#"><u>ANSP</u></a> automation is required. For the Element 2 and 3 upgrades, additional downlink and real time processing of aircraft observed wind information will be required. There are no aircraft equipage costs besides costs incurred for other Module upgrades.</p> <p>Impact of the Element 3 upgrade is reduced time that an airport must space departures on its CSPR two to three minutes apart, depending on runway configuration. Element 3 upgrade will provide more time periods that an airport’s ANSP can safely use WTMD reduced wake separations on their CSPR. The airport’s departure capacity increases 4 to 8 more departure operations per hour when WTMD reduced separations can be used. Downlink and real time processing of aircraft observed wind information will be required. There are no aircraft equipage costs besides costs incurred for other Module upgrades.</p>
----------------------------	--

**3. Necessary Procedures (Air & Ground)**

**Element 1**

The change to the ICAO wake separation minima implemented in the Block 1 timeframe will add potentially

60 or more individual aircraft-to-aircraft Leader/Follower Pair-Wise Static wake separations that ANSPs can choose to apply in their airport operations. ANSPs will be able to choose how they will implement the additional standards into their operations depending on the capacity needs of the airport. If capacity is not an issue at an airport, the ANSP may elect to use the original 3 categories in place before the Block 0 upgrade or the 6 Category standards put in place by Block 0. The ANSP procedures, using the Leader/Follow Pair-Wise Static set of standards, will need automation support in providing the required aircraft-to-aircraft wake separations to its air traffic controllers.

Implementing Element 1 will not require any changes to air crew flight procedures. However, there will be changes required in how a flight plan is filed in terms of the aircraft's wake classification.

### **Element 2**

The Block 0 implementations impacting the use of an airport's CSPR for arrivals, only affect the ANSP procedures for sequencing and segregating aircraft to the CSPR. Block 1 upgrade adds procedures for applying reduced wake separations between pairs of aircraft during arrivals to an airport's CSPR when crosswinds along the approach path are favourable for the reduced separations. Use of Block 1 procedures requires the addition to the ANSP automation platforms the capability to predict and monitor the crosswind and to display to the air traffic controller the required wake separation between aircraft arriving on the CSPR.

The procedures implemented by Element 2 require no changes to the air crew's procedures for accomplishing an instrument landing approach to the airport. Sequencing, segregating and separation will remain the responsibility of the ANSP.

### **Element 3**

Block 1 Element 3 implementations only affect the ANSP procedures for departing aircraft on an airport's CSPR. Element 3 products are additional procedures for use by the ANSP for situations when the airport is operating under a heavy departure demand load and the airport will be having a significant number of Boeing 757 and heavier aircraft in the operational mix. The procedures provide for transitioning to and from reduced required separations between aircraft and criteria for when the reduced separations should not be used. Block 1 upgrade does not change these procedures, it only increases the frequency and duration that the procedures can be applied. The procedures implemented by Element 3 require no changes to the aircrew's procedures for accomplishing a departure from the airport. When a specialized CSPR departure procedure is being used at an airport, pilots are notified that the special procedure is in use and that they can expect a more immediate departure clearance.

## **4. Necessary System Capability**

### **4.1 Avionics**

Module 70, Block 1 upgrade requires no additional technology to be added to the aircraft or additional aircrew certifications. Block 1 upgrades will utilize aircraft avionics enhancements that are expected to occur during that timeframe from other Modules (i.e. [ADS-B](#)).

### **4.2 Ground Systems**

ANSPs, if they choose to use the Leader/Follower Pair-Wise Static wake separation minima Element 1 upgrade will develop a decision support tool to support in the application the standards. The Element 2 and Element 3 Block 1 upgrades require the ANSP, if the ANSP chooses to use the reduced wake separations on its CSPR, add the capability to predict crosswind strength and direction and to display that information to the ANSP controllers and supervisors. This capability will be provided by a combination of X-band radar and Lidar scanner technology. The delivery of the weather information required to compute the reduced wake separations will be best supported by a SWIM infrastructure and associate services.

## **5. Human Performance**

### **5.1 Human Factors Considerations**

**5.1.1** The identification of Human Factors considerations is an important enabler in identifying processes and procedures for this module. In particular, the human-machine interface for the automation

aspects of this performance improvement will need to be considered and where necessary accompanied by mitigation risk mitigation strategies such as training, education and redundancy.

## **5.2 Training and Qualification Requirements**

5.2.1 Training will be required for controllers in the use of new Pair Wise Static matrix of aircraft type wake separation pairings and Wake Mitigation decision support tools.

5.2.2 Training in the operational standards and procedures will be identified along with the standards and recommended practices necessary for this module to be implemented. Likewise the qualifications requirements will be identified and included in the regulatory readiness aspects of this module when they become available.

## **6. Regulatory/standardization needs and Approval Plan (Air & Ground)**

- Regulatory/Standardization: Updates required to current published criteria given in Section 8.4
- Approval Plans: To Be Determined.

### **6.1 Element 1**

The product of Element 1 is a recommended set of Leader/Follower Pair-Wise Static additional wake separation changes to the ICAO wake separation minima and supporting documentation. Once approved, ICAO's revised wake separation minima will allow all ANSPs to base their wake mitigation procedures on the ICAO approved standards. ICAO approval of the Leader/Follower Pair-Wise Static wake separation minima is estimated to occur in the 2015/16 time frame.

### **6.2 Element 2 and 3**

Element 2 and 3 products are U.S. airport specific and are approved for use through a national review process to insure proper integration into the air traffic control system. A companion process (FAA Safety Management System) reviews and documents the safety of the product, insuring the safety risk associated with the use of the product is low.

There is no air approval plan required for the implementation of the Wake Turbulence Standards – Refined Module Block 1.

## **7. Implementation and Demonstration Activities**

### **7.1 Current Use**

The WTMD system has been operationally demonstrated at three U.S. airports beginning in 2011.

### **7.2 Planned or Ongoing Trials**

Concurrent with the ICAO approval process, the FAA is developing documentation and adapting its automation systems to allow implementation of the wake separation standard. The ICAO approval is expected in 2015/16.

Work is continuing on developing crosswind based wake separation procedures and technology upgrades for arrival operations to and airport's CSPR. Human-in-the-loop simulations using the procedures and the associated controller display support will be conducted in 2012. Depending on the outcome of the simulations, the development of the capability may continue.

Wake Turbulence Mitigation for Departures (WTMD) is a development project by the U.S. that will allow, when runway crosswinds are of sufficient strength and persistence, aircraft to depart on the up wind CSPR after a Boeing 757 or heavier aircraft departs on the downwind runway – without waiting the current required wake mitigation delay of 2 to 3 minutes. WTMD is being developed for implementation at eight to ten U.S. airports that have CSPR with frequent favourable crosswinds and a significant amount of Boeing 757 and heavier aircraft operations. First operational use of WTMD is expected in spring 2011.

## **8. Reference Documents**

### **8.1 Standards**

### **8.2 Procedures**

### **8.3 Guidance Material**

### **8.4 Approval Documents**

- ICAO Doc 4444, *Procedures for Air Navigation Services — Air Traffic Management*;
- ICAO Doc 9426, *Air Traffic Services Planning Manual*.

## Module N° B2-70: Advanced Wake Turbulence Separation (Time-based)

<b>Summary</b>	The application of time-based aircraft-to-aircraft wake separation minima and changes to the procedures the <a href="#">ANSP</a> uses to apply the wake separation minima.	
<b>Main Performance Impact</b>	KPA-02 Capacity;	
<b>Operating Environment / Flight Phases</b>	Aerodrome	
<b>Applicability Considerations</b>	Most Complex - Establishment of time-based separation criteria between pairs of aircraft extends the existing variable distance re-categorization of existing wake turbulence into a conditions specific time-based interval. This will optimize the inter-operation wait time to the minimum required for wake disassociation and runway occupancy. Runway throughput is increased as a result.	
<b>Global Concept Component(s)</b>	CM – Conflict Management	
<b>Global Plan Initiatives (GPI)</b>	GPI-13 Aerodrome Design GPI 14 Runway Operations	
<b>Main Dependencies</b>	B1-70	
<b>Global Readiness Checklist</b>		<b>Status</b> (ready now or estimated date)
	Standards Readiness	Est. 2023
	Avionics Availability	N/A
	Ground Systems Availability	Est. 2023
	Procedures Available	Est. 2023
	Operations Approvals	Est. 2023

### 1. Narrative

#### 1.1 General

Refinement of the Air Navigation Service Provider (ANSP) aircraft-to-aircraft wake mitigation processes, procedures and standards to time-based assignment will allow increased runway capacity with the same or increased level of safety. Block 2 upgrade will be accomplished without any required changes to aircraft equipage or changes to aircraft performance requirements although full benefit from the upgrade will require, as in block 1, aircraft broadcasting their aircraft based real-time weather observations during their airport approach and departure operations to continually update the model of local conditions. The upgrade is dependent on the block 1 establishment of wake turbulence characterization based on the wake generation and wake upset tolerance of individual aircraft types.

##### 1.1.1 Baseline

Turbulence Module B1-70 will have resulted in the use of dynamic wake turbulence separations to increase runway throughput while maintaining safety levels.



**1.1.2 Change brought by the module**

Module B2–70 represents a shift to time-based application of module B1-70 expanded distance based wake separation minima and ANSP wake mitigation procedures upgrade. B1-70 represented technology being applied to make available further runway capacity savings by enhancing the efficiency of wake turbulence separation minima by expanding the 6 category wake separation minima to a Leader/Follower - Pair Wise Static matrix of aircraft type wake separation pairings (potentially 64 or more separate pairings). Automation supported the ANSP by providing the minimum distance to be applied by the ANSP between pairs of aircraft. That expanded matrix represented a less conservative, but albeit still conservative, conversion of essentially time-based wake characteristics into a standard set of distances.

B1-70’s goal was to reduce the number of operations in which an excessive wake spacing buffer reduced runway throughput. This module uses the underlying criteria represented in the expanding re-categorization, the current winds, assigned speeds, and real time environmental conditions to dynamically assess the proper spacing between the aircraft to achieve wake separation. It couples that information with expect runway occupancy to establish a time spacing that provides a safe separation. These time-based separations are provided with support tools to the ANSP on their displays, and to the flight deck in the instances of cooperative separation which assumes already available flight deck tools for interval management. Further development of the Time-based separation will use Weather dependent separation (WDS) which develops the basic weather dependent concepts further and integrated with Time-Based Separation for approach. This concept utilises both wake decay and transport concepts (such as P-TBS and CROPS) into a single coherent concept, backed by advanced tools support and provides further landing rate improvements and resilience.

**2. Intended Performance Operational Improvement**

**Metrics to determine the success of the module are proposed in the *Manual on Global Performance of the Air Navigation System (Doc 9883)*.**

<i>Capacity</i>	
-----------------	--

<i>CBA</i>	
------------	--

**3. Necessary Procedures (Air & Ground)**

***Implement Leader/Follower - Pair Wise Time-based Separation Minima***

The change to the ICAO wake turbulence separation minima implemented in the Block 2 timeframe will change from a distance based separation that was expanded through the previous blocks from 3 to 60 or more to tailored time-based minima.

Implementing Block 2 will not require any changes to air crew flight procedures.

**4. Necessary System Capability**

**4.1 Avionics**

TBD

**4.2 Ground System**

This new ANSP procedure will need automation support in providing the required time-based aircraft-to-aircraft wake separations to its air traffic controllers.



## 5. Human Performance

### 5.1 Human Factors Considerations

**5.1.1** This module is still in the research and development phase so the human factors considerations are still in the process of being identified through modelling and beta testing. Future iterations of this document will become more specific about the processes and procedures necessary to take the human factors considerations into account. There will be a particular emphasis on identifying the human-machine interface issue if there are any and providing the high risk mitigation strategies to account for them.

### 5.2 Training and Qualification Requirements

**5.2.1** This module will eventually contain and number of personnel training requirements. As and when they are developed, they will be included in the documentation supporting this module and their importance signified. Likewise, any qualifications requirements that are recommended will become part of the regulatory needs prior to implementation of this performance improvement.

## 6. Regulatory/standardization needs and Approval Plan (Air & Ground)

- Regulatory/Standardization: New or updated criteria for Advanced Wake Vortex based operations are needed to the documents given in Section 8.4;
- Approval Plans: To Be Determined.

### 6.1 Implement Leader/Follower - Pair Wise Time-based Separation Minima

The product of this activity is a new procedure with supporting automaton requirements to establish time-based separation minima for high density and high throughput terminal areas. This will require an expansion of ICAO wake separation minima and supporting documentation. Once approved, ICAO's revised wake separation minima will allow all ANSPs to base their wake mitigation procedures on the ICAO approved standards.

## 7. Implementation and Demonstration Activities

### 7.1 Current Use

None at this time

### 7.2 Planned or Ongoing Trials

US – No current trials or demonstration planned at this time.

## 8. Reference Documents

### 8.1 Standards

### 8.2 Procedures

### 8.3 Guidance Materials

This module also incorporates R199 Doc 9882. **Approval Documents**

- ICAO Doc 4444, *Procedures for Air Navigation Services — Air Traffic Management*;
- ICAO Doc 9426, *Air Traffic Services Planning Manual*.

## Performance Improvement Area 1: Greener Airports

*Thread:* [AMAN/DMAN](#)

## Module N° B0-15: IMPROVE TRAFFIC FLOW THROUGH RUNWAY SEQUENCING (AMAN/DMAN)

<b>Summary</b>	To manage arrivals and departures (including time-based metering) to and from a multi-runway aerodrome or locations with multiple dependent runways at closely proximate aerodromes to efficiently utilize the inherent runway capacity	
<b>Main Performance Impact</b>	KPA-02 Capacity; KPA-04 Efficiency; KPA-09 Predictability KPA-06 Flexibility	
<b>Applicability Considerations</b>	Runways and Terminal Manoeuvring Area in major hubs and metropolitan areas will be most in need of these improvements.  The improvement is Least Complex – Runway Sequencing procedures are widely used in aerodromes globally. However, some locations might have to confront environmental and operational challenges that will increase the complexity of development and implementation of technology and procedures to realize this module	
<b>Global Concept Element(s)</b>	TS – Traffic Synchronization	
<b>Global Plan Initiative</b>	<b>GPI-6</b> Air Traffic Flow Management	
<b>Main Dependencies</b>	Linkage with B0-15 and B0-80	
<b>Global Readiness Checklist</b>		<b>Status</b> (ready or date)
	Standards Readiness	√
	Avionics Availability	√
	Ground System Availability	√
	Procedures Available	√
	Operations Approvals	√

### 1. Narrative

#### 1.1 General

In Block 0 (present – 2013), Basic queue management tools such as arrival or departure sequencing systems will provide runway sequencing and metering/scheduling support to the [ANSP](#), like Traffic Management Advisor (TMA) in the US or various implementations of AMAN at a number of aerodromes in Europe and other regions as well.

##### 1.1.1 Baseline

The baseline of this module is the manual process by which the air traffic controller uses local procedures and his expertise to sequence departures or arrivals in real time. This is generally leading to sub-optimal solutions both for the realised sequence and the flight efficiency, in particular in terms of taxi times and ground holding for departures, and in terms of holding for arrivals.

##### 1.1.2 Change brought by the module

Metering. The module introduces system capabilities to provide assistance for sequencing and metering. Arriving flights are “metered” by Control Time of Arrival (CTAs) and must arrive at a defined point close to the aerodrome by this time. Metering allows ATM to sequence arriving flights such that terminal and aerodrome resources are utilized effectively and efficiently. The system enhances the ability of en-route [ATC](#) to anticipate and improve the presentation of traffic arriving to an airport over long distances from that airport.

For departures, the sequence will allow improved start/push-back clearances, reducing the taxi time and ground holding, delivering more efficient departure sequences, reducing surface congestion and making terminal and aerodrome resources are utilized effectively and efficiently.

DMAN and TMA/DFM maximizes the use of airspace capacity and to assure full utilization of resources, they have the additional benefit of fuel efficient alternatives to reduce airborne and ground holding in an era in which fuel continues to be a major cost driver and emissions is a high priority. The use of these tools to assure facility of more efficient arrival and departure paths is a main driver in some modules of Block 0.

**1.2 Element 1: AMAN and Time-based Metering**

Arrival management sequences the aircraft, based on the airspace state, wake turbulence, aircraft capability, and user preference. The established sequence allows deriving the time that aircraft may have to lose before a reference approach fix, thereby allowing to fly more efficiently to the that fix and to reduce the use of holding stacks, in particular at low altitude. The smoothed sequence allows increase aerodrome throughput.

Time-based metering is the practice of separation by time rather than distance. Typically, the relevant [ATC](#) authorities will assign a time in which a flight must arrive at the aerodrome. This is known as the Control Time of Arrival (CTAs). CTAs are determined based on aerodrome capacity, terminal airspace capacity, aircraft capability, wind and other meteorological factors. Time-based metering is the primary mechanism in which arrival sequencing is achieved.

**1.3 Element 2: Departure Management**

Departure management, like its arrival counterpart, serves to optimize departure operation to ensure the most efficient utilization of aerodrome and terminal resources. Slots assignment and adjustments will be supported by departure management automations like [DMAN](#) or DFM. Dynamic slot allocation will foster smoother integration into overhead streams and help the airspace users better meet metering points and comply with other ATM decisions. Departure management sequences the aircraft, based on the airspace state, wake turbulence, aircraft capability, and user preference, to fit into the overhead en-route streams without disrupting the traffic flow. This will serve to increase aerodrome throughput and compliance with allotted departure time.

**2. Intended Performance Operational Improvement**

**Metrics to determine the success of the module are proposed in the *Manual on Global Performance of the Air Navigation System (Doc 9883)*.**

<i>Capacity</i>	Time-based metering will optimize usage of terminal airspace and runway capacity. Optimized utilization of terminal and runway resources.
<i>Efficiency</i>	<i>Harmonized arriving traffic flow from en-route to terminal and aerodrome. Harmonization is achieved via sequencing arrival flights based on available terminal and runway resources.</i> Efficiency is positively impacted as reflected by increased runway throughput and arrival rates. Streamline departure traffic flow and ensure smooth transition into en-route airspace. Decreased lead time for departure request and time between CFR and departure time. Automated dissemination of departure information and clearances.
<i>Predictability</i>	Decrease uncertainties in aerodrome/terminal demand prediction
<i>Flexibility</i>	Enables dynamic scheduling.

<a href="#">CBA</a>	<p>A detailed business case has been built for the Time-based Flow Management program in the US. The business case has proven that the benefit/cost ratio to be positive. Implementation of time-based metering can reduce airborne delay. This capability was estimated to provide over 320,000 minutes in delay reduction and \$28.37 million in benefits to airspace users and passengers over the evaluation period.<sup>1</sup></p> <p>Results from field trials of Departure Flow Management, a departure scheduling tool in the US, have been positive. Compliance rate, a metric use to gauge the conformance to assigned departure time, has increased at field trial sites from 68% to 75%. Likewise, the EUROCONTROL's <a href="#">DMAN</a> has demonstrated positive results. Departure scheduling will streamline flow of aircraft feeding the adjacent center airspace based on that center's constraints. This capability will facilitate more accurate ETAs. This allows for the continuation of metering during heavy traffic, enhanced efficiency in the <a href="#">NAS</a> and fuel efficiencies. This capability is also crucial for extended metering.</p>
---------------------	--

### 3. Necessary Procedures (Air & Ground)

The US TBFM and EUROCONTROL [AMAN/DMAN](#) efforts provide the systems and operational procedures necessary. In particular, procedures for the extension of metering into en-route airspace will be necessary. RNAV/RNP for arrival will also be crucial as well.

### 4. Necessary System Capability

#### 4.1 Avionics

No Avionics capability is required in support of the time-based metering for Departure. For Approach time base metering is mainly achieved through ATC speed clearance to adjust the aircraft sequence in the AMAN. This operation can be facilitated by requiring the aircraft to meet a [CTA](#) at a metering fix, relying on the aircraft RTA function from current [FMS](#).

#### 4.2 Ground Systems

The key technological aspects include automation support for the synchronization of arrival sequencing, departure sequencing, and surface information; improve predictability of arrival flow, further hone sector capacity estimates, and management by trajectory. Less congested locations might not require extensive automation support to implement.

Both TBFM and Arrival/Departure Management (AMAN/DMAN) application and existing technologies can be leveraged, but require site adaptation and maintenance.

<sup>1</sup> Exhibit 300 Program Baseline Attachment 2: Business Case Analysis Report for TBFM v2.22

## 5. Human Performance

### 5.1 Human Factors Considerations

**5.1.1** ATM personnel responsibilities will not be affected directly. However, human factors have been taken into consideration during the development of the processes and procedures associated with this module. Where automation is to be used, the Human-Machine interface has been considered from both a functional and ergonomic perspective (See Section 6 for examples). The possibility of latent failures however, continues to exist and vigilance is requested during all implementation actions. It is further requested that human factor issues, identified during implementation, be reported to the international community through ICAO as part of any safety reporting initiative.

### 5.2 Training and Qualification Requirements

**5.2.1** Automation support is needed for Air Traffic Management in airspace with high demands. Thus, training is needed for ATM personnel.

**5.2.2** Training in the operational standards and procedures are required for this module and can be found in the links to the documents in Section 8 to this module. Likewise, the qualifications requirements are identified in the regulatory requirements in Section 6 which form an integral part to the implementation of this module..

## 6. Regulatory/Standardization Needs and Approval Plan (Air & Ground)

- Regulatory/Standardization: Updates required to current published criteria given in Section 8.
- Approval Plans: To Be Determined.

## 7. Implementation and Demonstration Activities

### 7.1 Current Use

#### 7.1.1 Time-based Metering

- **United States** - Traffic Management Advisor is currently used in the US at 20 Air Route Traffic Control Centers (ARTCCs) as the primary time-based metering automation. [NextGen](#) efforts will field Time-based Flow Management, the augmentation to the Traffic Management Advisor, incrementally.
- **Europe** - Basic AMAN is already implemented in some European countries like, Belgium, Denmark, France, and UK. [DMAN](#) is deployed at major European hubs such as Charles De Gulle.
- **Other regions** - There some AMAN implementation in Australia, South Africa or Singapore.

#### 7.1.2 Departure Flow Management

- **United States** - Departure Flow Management has been in operational trial at 2 locations. Initial Operational Capability is expected to occur in 2014.
- **Europe** - DMAN is deployed at major European hubs such as Charles de Gaulle.

### 7.2 Planned or Ongoing Trials

#### 7.2.1 Time-based Metering

- **United States** - Currently conducting simulation of Terminal Metering in support of RNAV / RNP procedures using KDAL as the scenario. Terminal Metering capabilities are expected to be integrated into TBFM by 2018.

#### 7.2.2 Departure Flow Management

- **United States** - [DFM](#) will be integrated with extended metering and become part of TBFM in the US in 2014.
- **Europe** - DMAN deployment is expected to cover most major aerodromes in Europe.

## **8. Reference Documents**

### **8.1 Standards**

### **8.2 Procedures**

### **8.3 Guidance Materials**

- European ATM Master Plan, Edition 1.0, March 2009, update in progress;
- SESAR Definition Phase Deliverable 2 – The Performance Target, December 2006;
- SESAR Definition Phase Deliverable 3 – The ATM Target Concept, September 2007;
- SESAR Definition Phase Deliverable 5 – SESAR Master Plan, April 2008;
- TBFM Business Case Analysis Report;
- NextGen Midterm Concept of Operations v.2.0;
- RTCA Trajectory Operations Concept of Use.

### **8.4 Approval Documents**



This Page Intentionally Left Blank

## Module N° B1-15: Improved Airport operations through Departure, Surface and Arrival Management

<b>Summary</b>	To extend arrival metering and integration of surface management with departure sequencing will improve runway management and increase airport performance and flight efficiency.	
<b>Main Performance Impact</b>	KPA-02 Capacity; KPA-04 Efficiency; KPA-05 Environment; KPA-06 Flexibility; KPA-09 Predictability, KPA-10 Safety	
<b>Operating Environment/ Flight Phases</b>	Aerodrome and Terminal	
<b>Applicability Considerations</b>	Runways and Terminal Manoeuvring Area in major hubs and metropolitan areas will be most in need of these improvements.  Complexity in implementation of this module depends on several factors. Some locations might have to confront environmental and operational challenges that will increase the complexity of development and implementation of technology and procedures to realize this module. PBN routes need to be in place.	
<b>Global Concept Element(s)</b>	TS – Traffic Synchronization AO – Airport operations	
<b>Global Plan Initiative</b>	GPI-6 Air Traffic Flow Management GPI-12 Functional integration of ground systems with airborne systems GPI-14 Runway operations GPI-16 Decision support systems and alerting systems	
<b>Pre-Requisites</b>	B0-15, B0-75	
<b>Global Readiness Checklist</b>		<b>Status</b> (ready now or estimated date)
	Standards Readiness	<b>Est 2018</b>
	Avionics Availability	<b>Est. 2018</b>
	Infrastructure Availability	<b>Est. 2018</b>
	Ground Automation Availability	<b>Est. 2018</b>
	Procedures Available	<b>Est. 2018</b>
	Operations Approvals	<b>Est. 2018</b>

### 1. Narrative

#### 1.1 General

In Block 1 (2018), departure management will be integrated with surface management. The augmented surface surveillance information can be tapped to provide more precise departure traffic planning and timely updates. In addition, enhanced surface management will increase aerodrome throughput without compromising wake turbulence separation and other safety protocols. Aerodrome capacity and throughput is closely tied to surface surveillance and management. Precise surface movement and guidance in all weather conditions and reduced runway occupancy time will immensely improve the efficiency of surface operations. In particular, improved surface surveillance and management will facilitate the optimal use of movement areas.

The synergy of precise surface management and departure sequencing will further hone the predictability and accuracy of departure times assigned to flights. It will enable departure dynamic spacing and sequencing, leading to a higher departure rate. Departure and arrival patterns can be adjusted to lessen the impact separation procedures posed.

Flights can be sequenced such that the effect of natural phenomena (i.e. wake turbulence) can be mitigated. Wake turbulence effects can be minimized by putting a series of heavy aircrafts behind light aircrafts, as wake turbulence generated by light aircrafts dissipates quickly. The coupling of surface and departure management enables greater flexibility in runway balancing. Runway can be re-configured to adapt and support the ever changing arrival and departure scenarios. The runway can be configured such that wake turbulence effects can be circumvented, e.g. dedicated runways for heavies and light aircrafts that diverge into different directions.

Expansion of time base metering into adjacent en-route airspace and more prevalent use of performance-based navigation PBN procedures, such as RNAV/RNP, will further optimize resource utilization in high density areas. The linkage will improve predictability, flexibility, and optimized departure and surface operations.

The expansion of time-based arrival metering into the adjacent en-route domain is also crucial part of this module. Extending metering enables adjacent [ATC](#) authorities to collaborate with each other and manage and reconcile traffic flows more effectively. Coordination between ATC authorities will require common situational awareness and consistent execution of ATM decisions. The coordination requires consistent trajectory, weather, and surveillance information exchange across Flight Information Regions (FIRs). Information such as CTAs, position, and convective weather must be uniformed and their interpretation consistent.

This module also seeks to increase the utilization of performance-based navigation procedures such as RNAV/RNP procedures in high density areas. RNAV/RNP procedures can efficiently direct flights into arrival and departure metering fixes. Procedures such as Standard Terminal Arrival (STAR) and Standard Instrument Departure (SID) are of tremendous efficacy in managing strained resources at high density areas. This will further optimize both aerodrome and terminal resource allocation.

### 1.1.1 Baseline

Module B0-15 introduced time-based arrival metering, arrival and departure management automation. These automations work independently, with the ATC personnel serving as the integrator of information generated by these systems.

**Arrival Metering in terminal airspace** reduced the uncertainty in airspace and aerodrome demand. Flights are controlled via Control Time of Arrival. The [CTA](#) dictates the time in which the flight must arrive or risk losing the slot. This enables ATM to predict, with reasonable accuracy, the future demand for terminal airspace and aerodrome. Terminal ATC authority can now adjust the arrival sequence to better utilise limited resources in the terminal domain.

**Departure management automation** provides departure scheduling. Departure scheduling will optimize the sequence in which the flow is fed to the adjacent ATC authorities. Departure is sequenced based on flights' arrival flow constraints if necessary (non-specialized or runways, departure/arrival interference). Departure management also provides automated disseminations and communication of departure restriction, clearance, and other relevant information.

Arrival and departure metering automation efforts maximizes the use of capacity and to assure full utilization of resources by assuring ATC authorities of more efficient arrival and departure paths. They have the secondary benefit of fuel efficient alternatives to hold stacks in an era in which fuel continues to be a major cost driver and emissions is a high priority.

### 1.1.2 Change brought by the module

This module will enable **surface management, extended arrival metering, and departure/surface integration**. Departure management automation will eliminate conflicts and provide smoother departure operations and streamlined synchronization with adjacent ATC authority. Enhanced surface movement tracking and control will decrease each flight's runway occupancy time on the aerodrome surface, thus boosting aerodrome throughput. In addition, integrated surface and departure management enable more flexible runway balancing, further increase aerodrome throughput. This integration will also facilitate more efficient and flexible departure operations and ensure optimized resource allocation both on the aerodrome surface and in the terminal airspace.

Extended arrival metering will foster greater accuracy and consistency in Control Time of Arrival (CTAs). Errors in CTAs in long range metering are inevitable, but can be mitigated via coordination between different [ATC](#) authorities. Coordination will lead to reconciliation of trajectory, weather, surveillance, and other relevant information for ATM. This coordination will eliminate misunderstanding and misinterpretation of ATM decisions. Delays will be contained in the en-route domain, where the airspace users can accommodate such delays in an economical manner.

Performance-based procedures such as RNAV/RNP in high density areas will lead to more optimal utilization of airspace. In addition to optimal airspace utilization, RNAV/RNP routes are more fuel efficient. The RNAV/RNP procedures streamline and un-tangled the arrival and departure flows to ensure continuous streams. These procedures lessen the negative impacts and transition time for modifying the configuration of the runways and their associated approach fixes. Time-based metering enables the continuous application of PBN procedures in high density operations.

### **1.2 Element 1: Surface Management**

Enhanced surface management includes improvements in the precision of surface movement tracking, conflict detection and control. Surface management manages runway demand and sequences the flights on the ground to support departure operations. Surface management streamlines the sequence to the departure threshold and ensure streamline operations. Such streamlined surface operations facilitate a more robust departure rates by decreasing each flight's time on the aerodrome surface. In addition, surface management provides taxi routing support. Taxi routes are devised based on the location of the aircraft, runway configuration, and user preferences.

### **1.3 Element 2: Departure and Surface Integration**

The integration of departure sequencing and surface management will foster greater predictability and flexibility in surface and departure operations. This integration will facilitate greater assigned departure time compliance, as enhanced surface movement tracking and control will improve the accuracy of the estimated departure slot time. Furthermore, surface and departure linkage enables dynamic sequencing and runway balancing. Flights can be sequenced to mitigate the effects of undesirable natural phenomena and restrictions. Runway and taxiway assignments will be tied to the projected runway demand, surface traffic level, gate location, and user preferences. Improved runway balancing will ensure that meet time in the airspace and the slot time on the surface are coordinated.

These measures serve to increase aerodrome throughput and departure rates.

### **1.4 Element 3: Extended Arrival Metering**

Extended metering will enhance predictability and ATM decision compliance. The ATC authorities can now meter across [FIR](#) boundaries. Extended metering enables ATC authorities to continue metering during high volume traffic and improve metering accuracy. This will also facilitate synchronization between adjacent en-route ATM authorities/FIRs. With extended metering, delays can be shifted to higher attitudes, where it can be more efficiently absorb by incoming flights. In addition, synchronization will foster a common method and message set among ATC authorities.

### **1.5 Element 4: Utilization of RNAV/RNP routes**

While performance-based procedures provide the most fuel efficient and lowest emission paths to the runway, in high demand conditions can make these procedures difficult to support at he meter fix. In order to service the demand and while maintaining individual flight efficiency, linking the RNAV/RNP procedures to the AMAN scheduler will allow sequencing of aircraft so they can funnel efficiently and directly to the metering fix from their Top of Descent (TOD) and enable the execution of [PBN](#) procedures such as Optimized Profile Descent (OPD). Time-based metering can sequence the incoming traffic via Controlled Time of Arrival (CTA) and RNAV/RNP assignment. Sequencing by CTA ensures the flight enable the utilization of Optimize Profile Descent from the Top of Descent and other RNAV/RNP procedures to a specific waypoint. Time-based metering allows the continuous utilization RNAV/RNP procedures during periods of high traffic volume.

## 2. Intended Performance Operational Improvement

Metrics to determine the success of the module are proposed in the *Manual on Global Performance of the Air Navigation System (Doc 9883)*.

<i>Capacity</i>	Time-based metering will optimize usage of terminal airspace and runway capacity.
<i>Efficiency</i>	Surface Management decreases runway occupancy time, more robust departure rates, and enables dynamic runway rebalancing and re-configuration. Departure/Surface integration enables dynamic runway rebalancing to better accommodate arrival and departure patterns. Reduction in airborne delay/holding <i>Traffic flow synchronization between en-route and terminal domain.</i> RNAV/RNP procedures will optimize aerodrome/terminal resource utilization.
<i>Predictability</i>	Decrease uncertainties in aerodrome/terminal demand prediction. Increased compliance with assigned departure time and more predictable and orderly flow into metering points Greater compliance to Controlled Time of Arrival (CTA) and more accurate assigned arrival time and greater compliance
<i>Flexibility</i>	Enables dynamic scheduling.
<i>Safety</i>	Greater precision in surface movement tracking
<i>Environmental</i>	Reduction in fuel burn and environment impact (emission and noise)

<a href="#">CBA</a>	<p>Surface management streamlines traffic flow on the aerodrome surface and facilitates more efficient use of runways and increase runway capacity. In addition, surface management streamlines departure flow and provides more predictable and gate-arrival times. Greater precision in surface movement tracking can reduce runway incursions and ensure aerodrome user's safety. Surface management also offers environmental benefits in fuel burn and noise abatement in some aerodromes.</p> <p>Integrated surface and departure management streamlines traffic flow on the aerodrome surface and facilitate more efficient use of runways and increase departure rates. This integration improves runway sequencing. Linked surface and departure management offers greater efficiency by synchronizing departure and surface operations. This synchronization ensures that departure activities in the terminal airspace are coordinated with runway state and activities. Surface and departure harmonization will also foster greater accuracy and consistency in runway and departure operations</p> <p>Extended metering enables adjacent ATM authorities coordinate departure scheduling and streamline flows to satisfy both sides' constraints. Departure sequencing can be adjusted to fit adjacent centre's arrival constraints. Coordination between two ATM authorities entails the coupling of metering points. Coupled metering points reduce the error in long range metering and reduces the need of Miles-In-Trail restrictions. In addition, the coupled metering points can serve to de-conflict traffic flow. Extended metering also reduces airborne delay by propagating any delay to domain where higher altitudes, where it can be absorb more effectively.</p> <p>RNAV/RNP routes represent the most efficient and precise routes. Utilization of RNAV/RNP routes and other <a href="#">PBN</a> procedures provide more reliable, repeatable, predictable, and efficient routing to metering fixes. Delays are reduced via improved trajectory prediction and schedule accuracy. More efficient routing brings about more robust throughput. RNAV/RNP routes are crucial components of the <a href="#">AMAN/DMAN</a> metroplex. In addition to improvement to operational efficiency, RNAV/RNP routes contribute to better fuel efficiency and noise/emission reduction. Improvement in arrival management via CTA will increase the application and utilization of these procedures.</p>
---------------------	--

### 3. Necessary Procedures (Air & Ground)

The TBFM and [AMAN/DMAN](#) efforts, along with other surface initiatives, provide the systems and operational procedures necessary. New procedures should be defined to describe role of each actors (Crew, ATS Units).

### 4. Necessary System Capability

#### 4.1 Avionics

#### 4.2 Ground Systems

For element 1, a surface management functionality that includes precise surface movement tracking, taxi routing and monitoring is required. Airport may choose to provide the taxi clearance using an air-ground data link functionality.

For element 2, automation support is required to support the integration of departure sequencing with surface management.

For element 3, a functionality is required to extend the arrival metering into en-route through enhanced coordination.

Finally for element 4 the arrival metering function needs to be updated to cater for aircraft navigation performances.

As a consequence, information exchange between [ATC](#), Airport operations and airlines operations will best be implemented using the SWIM infrastructure.

### 5. Human Performance

#### 5.1 Human Factors Considerations

**5.1.1** Automation support is needed for Air Traffic Management in airspace with high demands. The identification of Human Factors considerations is an important enabler in identifying processes and procedures for this module. In particular, the human-machine interface for the automation aspects of this performance improvement will need to be considered and where necessary accompanied by mitigation risk mitigation strategies such as training, education and redundancy.

#### 5.2 Training and Qualification Requirements

**5.2.1** Training on the required automation is needed for ATM personnel. ATM personnel responsibilities will not be affected. Training in the operational standards and procedures will be identified along with the standards and recommended practices necessary for this module to be implemented. Likewise the qualifications requirements will be identified and included in the regulatory readiness aspects of this module when they become available.

### 6. Regulatory/standardization needs and Approval Plan (Air & Ground)

- **Regulatory/Standardization:** Updates required for surface management, surface CDM, and operations to current published criteria given in Section 8.4.
- **Approval Plans:** To Be Determined

**Discussion:** Surface management will entail policies on surface information sharing, roles and responsibilities of all users of the aerodrome surface, and mutual understanding/acceptance of operational procedures. A framework, similar to [A-CDM](#) in Europe and surface CDM in the US, should be established to serve as a forum for all stakeholders to discuss relevant issues and concerns.

Integrated surface and departure management will entail policies and mutual understanding/acceptance of optimized operational procedures for automated surface movement planning/guidance and departure operations. Coordination of meet time and slot time should be managed as part of the optimized operational procedures as well.

Operational procedures and standards for extended metering exist in different manifestations depending on region. Extended metering might require the modification or the addition of metering points. Approvals might be needed for such revision.

Operational procedures and standards, along with performance requirements for RNAV/RNP routes are needed for its implementation.

## 7. Implementation and Demonstration Activities

### 7.1 Current Use

#### 7.1.1 Surface Management

None at this time.

#### 7.1.2 Departure and Surface Integration

Departure and surface management synchronization is currently achieved mostly through human coordination.

#### 7.1.3 Extended Metering

**United States** - Extended metering is in current use in the US as part of TBFM.

#### 7.1.4 Utilization of RNAV/RNP routes

**United States** – Terminal Metering which will provide merging and spacing capability to enable utilization of RNAV / RNP routes will be implemented by 2018.

### 7.2 Planned or Ongoing Trials

SMAN (Surface Manager) will be introduced as the go-to surface management tool in Europe. Similarly, Tower Flight Data Manager (TFDM) will be introduced in the US to fulfil the same role. SMAN is a function in the ASMGCS tool to maintain a safe and efficient traffic flow on the surface.

Departure and surface management synchronization is a crucial component in the US Time-based flow management (TBFM) and [AMAN/DMAN](#)/SMAN efforts in the US and Europe. Departure and surface management harmonization will be implemented as these capabilities mature.

The TBFM program in the US seeks to augment TMA (Trajectory Management Advisor) and strive to close the performance gaps in TMA. Generally, time-based flow management (TBFM) aims to improve and optimize the sequencing to maximize airspace utilization. In addition, TBFM will extend metering and sequencing to other domains and incorporate delay information imposed on flights by TMIs (Traffic Management Initiatives). Similarly, AMAN/DMAN works toward integrated, synchronized sequencing of all flight phases.

Extended AMAN is considered in Initial 4D SESAR project

The aims of the US and European efforts are congruous.

Extended metering will be implemented along with these capabilities as they mature.

#### 7.2.1 Surface Management

Surface movement tracking and navigational systems, such as the [ASDE-X](#) in the US and initial ASMGCS (Advanced Surface Movement Guidance and Control System) in Europe, are deployed to support tracking, guidance, routing and planning of surface operations.

- **United States** - The Collaborative Departure Queue Management CDS concept will be evaluated in field tests by the FAA during the Surface Trajectory Based Operations (STBO) projects. The Human-in-the-Loop used the system to manage a set of flights through several simulated air traffic scenarios. A current FAA air traffic manager set constraints on airspace capacities.

In 2010, New York John F. Kennedy International Airport (JFK) underwent a four-month runway resurfacing and widening project in one of the United States' busiest airspaces. The longest runway was expanded to accommodate new, larger aircraft. The construction project also included taxiway improvements and construction of holding pads. In order to minimize disruption during construction, JFK decided to use a



collaborative effort using departure queue metering. With CDQM, departing aircraft from JFK's many airlines was allocated a precise departure slot and waited for it at the gate rather than congesting taxiways. The procedures used during the construction project worked so well that they were extended after the runway work was completed.

Boston Logan International Airport hosted a demonstration to study the maximum number of aircraft authorized to push back and enter an airport's active movement area during a set time period. The goal was to conduct continuous runway operations without any stop and go movements. In August through September, preliminary findings indicated the following savings: 18 hours of taxi-time, 5100 gallons of fuel and 50 tons in carbon dioxide.

- **SESAR:** SMAN (Surface Manager) will be introduced as the go-to surface management tool in Europe. Similarly, TFDM will be introduced in the US to fulfil the same role. SMAN is a function in the ASMGCS tool to maintain a safe and efficient traffic flow on the surface. Enhanced surveillance will be defined, verified and in-field validated within the SESAR programme in the 2010-2015 time frame.

### 7.2.2 Departure and Surface Integration

**SESAR:** Trials on the integration of Surface Management with Arrival Management and Departure Management in the CDM processes validating the route generator ability to propose conflict free routes and the provision of planned routes through datalink in 2014.

Trials on coupled Departure Management capabilities for establishing the pre departure sequence with sufficient quality taking into account surface and departure management processes in 2011.

### 7.2.3 Extended Metering

- **United States** – 3D PAM will provide extended metering from En Route Airspace to the meter to the terminal areas with merging and spacing required for RNAV / RNP Procedures.
- **SESAR:** Validation of [P-RNAV](#) application integrated with SESAR Arrival Management in complex TMAs with more than one airport in 2012-2014 timeframe.

Validation of extended arrival management in en-route airspace in 2012-2014 timeframe.

### 7.2.4 Utilization of RNAV/RNP routes

- **United States** – Demonstration of Terminal Metering to merge and space RNAV / RNP procedures are currently being conducted to determine functional and operational requirements.
- **SESAR:** Trials on computed and predicted single Controlled Time of Arrival (CTA) in 2012-2013 timeframe.

Validation of multiple Controlled Time of Arrival (CTA) in 2015.

## 8. Reference Documents

### 8.1 Standards

### 8.2 Procedures

### 8.3 Guidance Material

- European ATM Master Plan, Edition 1.0, March 2009, update in progress
- SESAR Definition Phase Deliverable 2 – The Performance Target, December 2006
- SESAR Definition Phase Deliverable 3 – The ATM Target Concept, September 2007
- SESAR Definition Phase Deliverable 5 – SESAR Master Plan, April 2008
- TBFM Business Case Analysis Report
- NextGen Midterm Concept of Operations v.2.0
- RTCA Trajectory Operations Concept of Use



#### **8.4 Approval Documents**

- ICAO Doc 4444, *Procedures for Air Navigation Services — Air Traffic Management*;
- ICAO Doc 9426, *Air Traffic Services Planning Manual*.

## Module N° B2-15: Linked [AMAN/DMAN](#)

<b>Summary</b>	Integrated AMAN/DMAN To enable dynamic scheduling and runway configuration to better accommodate arrival/departure patterns. integrate arrival and departure management. The module also summarizes the benefits of such integration and the elements that facilitate it.	
<b>Main Performance Impact</b>	KPA-02 Capacity; KPA-04 Efficiency; KPA-09 Predictability KPA-06 Flexibility	
<b>Operating Environment/ Flight Phases</b>	Aerodrome and Terminal	
<b>Applicability Considerations</b>	Runways and Terminal Manoeuvring Area in major hubs and metropolitan areas will be most in need of these improvements.  The implementation of this module is Least Complex.  Some locations might have to confront environmental and operational challenges that will increase the complexity of development and implementation of technology and procedures to realize this block.  Infrastructure for RNAP/RNP routes need to be in place.	
<b>Global Concept Element(s)</b>	TS – Traffic Synchronization	
<b>Global Plan Initiative</b>	<b>GPI-6</b> Air Traffic Flow Management	
<b>Main Dependencies</b>	B1-15	
<b>Global Readiness Checklist</b>		<b>Status</b> (ready now or estimated date)
	Standards Readiness	<b>Est. 2025</b>
	Avionics Availability	<b>Est. 2025</b>
	Ground Systems Availability	<b>Est. 2025</b>
	Procedures Available	<b>Est. 2025</b>
	Operations Approvals	<b>Est. 2025</b>

### 1. Narrative

#### 1.1 General

In Block 2 (2023), departure and arrival sequencing will be synchronized. Arrival and departure exact strains on the same aerodrome resources. Thus, the coupling of arrival and departure manager will harmonize and de-conflict the respective flows and enable more efficient runway utilization. ATM authorities can now coordinate arrival and departure activities and devise an arrival/departure sequence that avoids conflicts between the two. The synchronization of arrival and departure management allows ANSPs to configure arrival and departure procedures to maximize utilization of aerodrome and terminal airspace.

Synchronization of arrival and departure sequences relies upon operational consistency and information homogeneity. Flight information, such as speed, position, restrictions, and other relevant information, must be uniform and share across all ATC authorities. Information homogeneity and common procedures are essential in achieving the operational consistency between ATC authorities that is the stepping stone for departure and arrival synchronization.

**1.1.1 Baseline**

Block 1 brought about the synchronization of surface and departure management. Specifically, surface management and departure sequencing will be linked to further streamline departure operations. Surface and departure activities will be coordinated. Precise surface movement reduces runway occupancy time and improves conformance to assigned departure time. RNAV/RNP procedures usage in high density terminal domain is more prevalent. Greater usage of RNAV/RNP procedures optimizes throughput and provides fuel-efficient routes for airspace users. Metering will also be extended into adjacent FIR airspace, ensure greater monitoring on conformance to Control Time of Arrivals. Extended metering will also assist in transitioning flights from en-route to terminal airspace.

**1.1.2 Change brought by the module**

In Block 2, arrival and departure sequencing will be synchronized, establishing a predictable and efficient stream of flights in the terminal and aerodrome airspace and optimizing both terminal procedures and runway configuration to accommodate the maximum volume of aircraft. Runway and airspace configuration can be dynamically adjusted to accommodate any change in the arrival/departure flow patterns. Dynamic sequencing of arrival and departure flow will aid in the optimization of terminal procedures by avoiding or lessening the impact of relevant restrictions. The coupled arrival and departure sequence can be adjusted to accommodate the demand and terminal domain resource constraints.

The primary benefits of such synchronization are optimized allocation of airspace/aerodrome resources, resulting in greater runway and airspace throughput. Arrival and departure flow can be sequenced to circumvent the negative impacts of natural phenomena, separation restrictions, and conflicts. This gives ATM greater latitude in coping with excess demand. Integrated arrival and departure management ensure that aircraft are optimally spaced to achieve the maximum throughput.

The synchronized information flow as the result of harmonization between departure and arrival also foster greater common situation awareness for all stakeholders. Information transferred between all ATC authorities involved will be reconciled to provide a common operational picture. This reduces the complexity.

**2. Intended Performance Operational Improvement**

**2 Metrics to determine the success of the module are proposed in the *Manual on Global Performance of the Air Navigation System (Doc 9883)*.**

<i>Capacity</i>	Decrease in Miles-in-Trail (MIT) restrictions implies greater capacity in the terminal and aerodrome domain
<i>Efficiency</i>	Optimize utilization of terminal and runway resources. a. Optimize and coordinate arrival and departure traffic flows in the terminal and aerodrome domain
<i>Predictability</i>	Decrease uncertainties in aerodrome/terminal demand prediction
<i>Flexibility</i>	Enables dynamic scheduling and dynamic runway configuration to better accommodate arrival/departure patterns

<a href="#"><u>CBA</u></a>	Linked AMAN/DMAN will reduce ground delay. In the US, the Integrated Arrival and Departure Capability (IDAC) provide over .99 million minutes in benefits over the evaluation period, or \$47.20 million (risk adjusted constant year) <sup>2</sup> in benefits to airspace users and passengers. Implementation of linked AMAN/DMAN will also increase compliance to ATM decision such as assigned arrival and departure time. Coordination of arrival and departure flow, along with modifications to airspace and aerodrome configuration will enhance throughput and airspace capacity. Reconfiguration of airspace to accommodate different arrival/departure patterns entails more agile terminal operations.
----------------------------	---

<sup>2</sup> Exhibitbit 300 Program Baseline Attachment 2: Business Case Analysis Report for TBFM v2.22

### 3. Necessary Procedures (Air & Ground)

The ICAO *Manual on Global Performance of the Air Navigation System* (ICAO Document 9883) provides guidance on implementing integrated arrival and departure consistent with the vision of a performance-oriented ATM System. The TBFM and [AMAN/DMAN](#) efforts, along with other initiatives, provide the systems and operational procedures necessary. Airspace integration and re-design maybe required.

Integration of AMAN, DMAN through increased automation is subject to research and validation. Supported by Airport CDM it will also require changes in the relationships between the actors. These efforts would provide the necessary operational procedures defining the role of each actor (Crew, ATS Units, airport) and their relations.

### 4. Necessary System Capability

#### 4.1 Avionics

No additional avionics (FMS) beyond Block 0 is required for the implementation of this module

#### 4.2 Ground Systems

Mechanism to share relevant information effectively and in a timely manner is essential to this element and also fosters greater common situational awareness between all users of the aerodrome and its surrounding airspace.

### 5. Human Performance

#### 5.1 Human Factors Considerations

**5.1.1** ATM personnel responsibilities will not be affected, however, this module is still in the research and development phase so the human factors considerations are still in the process of being identified through modelling and beta testing. Future iterations of this document will become more specific about the processes and procedures necessary to take the human factors considerations into account. There will be a particular emphasis on identifying the human-machine interface issue if there are any and providing the high risk mitigation strategies to account for them.

#### 5.2 Training and Qualification Requirements

**5.2.1** Automation support is needed for Air Traffic Management in airspace with high demands. Thus, training is needed for ATM personnel.

**5.2.2** This module will eventually contain and number of personnel training requirements. As and when they are developed, they will be included in the documentation supporting this module and their importance signified. Likewise, any qualifications requirements that are recommended will become part of the regulatory needs prior to implementation of this performance improvement.

### 6. Regulatory/standardization needs and Approval Plan (Air & Ground)

- **Regulatory/Standardization:** Updates required for policies on arrival and departure information sharing, roles and responsibilities of all users of the aerodrome surface and terminal airspace, and mutual understanding/acceptance of operational procedures in published criteria that includes those given in Section 8.4.
- **Approval Plans:** To Be Determined

### 7. Implementation and Demonstration Activities

#### 7.1 Current Use

There is no current operational use of departure and arrival management integration automation.

#### 7.2 Planned or Ongoing Trials

. No currently planned trials or demonstrations at this time

## **8. Reference Documents**

### **8.1 Standards**

### **8.2 Procedures**

### **8.3 Guidance Material**

- European ATM Master Plan, Edition 1.0, March 2009, update in progress;
- SESAR Definition Phase Deliverable 2 – The Performance Target, December 2006;
- SESAR Definition Phase Deliverable 3 – The ATM Target Concept, September 2007;
- SESAR Definition Phase Deliverable 5 – SESAR Master Plan, April 2008;
- TBFM Business Case Analysis Report;
- NextGen Midterm Concept of Operations v.2.0;
- RTCA Trajectory Operations Concept of Use.

### **8.4 Approval Documents**

- ICAO Doc 4444, *Procedures for Air Navigation Services — Air Traffic Management*;
- ICAO Doc 9426, *Air Traffic Services Planning Manual*.

## Module N° B3-15: Integration AMAN/DMAN/SMAN

<b>Summary</b>	This module includes a brief description of integrated arrival, en-route, surface, and departure management.	
<b>Main Performance Impact</b>	KPA-02 Capacity; KPA-04 Efficiency; KPA-09 Predictability KPA-06 Flexibility	
<b>Operating Environment/ Flight Phases</b>	All phases of flight (JORDAN)	
<b>Applicability Considerations</b>	Runways and Terminal Manoeuvring Area in major hubs and metropolitan areas will be most in need of these improvements.  Complexity in implementation of this block depends on several factors. Some locations might have to confront environmental and operational challenges that will increase the complexity of development and implementation of technology and procedures to realize this block. Infrastructure for RNAP/RNP routes need to be in place.	
<b>Global Concept Element(s)</b>	TS – Traffic Synchronization	
<b>Global Plan Initiative</b>	<b>GPI-6</b> Air Traffic Flow Management	
<b>Main Dependencies</b>	B2-15. Reinforces benefits derived from B3-10, B3-25, B3-85 and B3-05	
<b>Global Readiness Checklist</b>	Standards Readiness	<b>Status</b> (ready now or estimated date)
	Avionics Availability	<b>Est. 2025+</b>
	Ground Systems Availability	<b>Est. 2025+</b>
	Procedures Available	<b>Est. 2025+</b>
	Operations Approval	<b>Est. 2025+</b>

### 1. Narrative

#### 1.1 General

With 4D trajectory operations, Block 3 will see the achievement of capabilities which optimize both the individual trajectories, the traffic flows and the use of scarce resources such as runways and surface. This module is focused on the capabilities related to the airport aspects.

Synchronization of all flight phases represents the full integration of all control loops. The use of 4D trajectories will increase predictability and reduce uncertainty between the planned and executed trajectory. Traffic synchronization also implies that information is synchronized across flight phases. .

#### 1.1.1 Baseline

Module B2-15 brings about the synchronization of arrival and departure management. Arrival and departure sequencing are linked to further augment airspace capacity and efficient terminal and aerodrome airspace design. However, the quality of the process is limited by the accuracy and predictability of trajectories available in the ground systems and the uncertainties in the actions of upstream stakeholders on the trajectory.

#### 1.1.2 Change brought by the module

With this module, a full traffic synchronization will be realized. The integration of surface, arrival, and departure management as well as en-route aspects lead to further optimize traffic flows and the efficient utilization of airspace and airport infrastructures. Conflict management, demand and capacity, and synchronization will be fully integrated.

This will exploit 4D control of flights in all phases of flight. In addition to the increased predictability, it will allow to maximize the airport throughput and flight efficiency. In particular, the integrated consideration of the downstream constraints will minimize the impact of tactical local interventions on the rest of the network or traffic flow.

Traffic synchronization will utilize a combination automation, procedures, and airspace modification to optimize throughputs in all domains – surface, departure, arrival, and en-route.

## 2. Intended Performance Operational Improvement

**Metrics to determine the success of the module are proposed in the *Manual on Global Performance of the Air Navigation System (Doc 9883)*.**

<i>Capacity</i>	Mitigate impacts of various restrictions and conflicts and allow a greater throughput
<i>Efficiency</i>	Optimize and coordinate arrival, departure, and surface traffic flows in the terminal and aerodrome domain.
<i>Predictability</i>	Optimized Time Profile and greater ATM decision compliance Gate-to-Gate 4D trajectory will mitigate uncertainties in demand prediction across all domains and enables better planning through all airspace.
<i>Flexibility</i>	Enables dynamic scheduling and dynamic runway configuration to better accommodate arrival/departure patterns
<a href="#">CBA</a>	Traffic synchronization brings about optimized flow free of conflict and choke points. The use of time profile enables both strategic and tactical flow management and improves predictability. In addition, traffic synchronization can be used as a tool to reconcile demand and capacity by reduction of traffic density.

## 3. Necessary Procedures (Air & Ground)

Full integration AMAN, DMAN and SMAN through increased automation and use of data link is subject to research and validation. These efforts would provide the necessary operational procedures defining the role of each actor (Crew, ATS Units, airport) and their relations.

## 4. Necessary System Capability

### 4.1 Avionics

Full Traffic Synchronization will require the aircraft to be capable of exchanging information regarding the 4D Trajectory Profile, and be able to adhere to an agreed 4D Trajectory.

### 4.2 Ground Systems

Traffic synchronization may require sequencing and optimization automation systems upgrades. These upgrades should support time-based management, integrated sequencing, and augmented surveillance capabilities.

## 5. Human Performance

### 5.1 Human Factors Considerations

**5.1.1** Analysis should be completed to determine if any changes to the Computer Human Interface are needed to enable ATM Personnel to best manage the 4D Trajectory Profiles.

**5.1.2** This module is still in the research and development phase so the human factors considerations are still in the process of being identified through modelling and beta testing. Future iterations of this document will become more specific about the processes and procedures necessary to take the human factors considerations into account. There will be a particular emphasis on identifying the human-machine interface issue if there are any and providing the high risk mitigation strategies to account for them.

### 5.2 Training and Qualification Requirements

**5.2.1** Automation support is needed for Air Traffic Management in airspace with high demands. Thus, training is needed for ATM personnel. ATM personnel responsibilities will not be affected.

**5.2.2** This module will eventually contain and number of personnel training requirements. As and when they are developed, they will be included in the documentation supporting this module and their importance signified. Likewise, any qualifications requirements that are recommended will become part of the regulatory needs prior to implementation of this performance improvement.

## 6. Regulatory/standardization needs and Approval Plan (Air & Ground)

- **Regulatory/Standardization:** New or updated policies for full traffic synchronization and all stakeholders are needed, addressing information sharing, roles and responsibilities in 4D trajectory management, along with new operational procedures.
- **Approval Plans:** To Be Determined.

## 7. Implementation and Demonstration Activities

### 7.1 Current Use

*None at this time*

### 7.2 Planned or Ongoing Trials

- **SESAR:** None at this time
- **NextGen:** None at this time

## 8. Reference Documents

### 8.1 Standards

### 8.2 Procedures

### 8.3 Guidance Material

- European ATM Master Plan, Edition 1.0, March 2009, update in progress;
- SESAR Definition Phase Deliverable 2 – The Performance Target, December 2006;
- SESAR Definition Phase Deliverable 3 – The ATM Target Concept, September 2007;
- SESAR Definition Phase Deliverable 5 – SESAR Master Plan, April 2008;
- TBFM Business Case Analysis Report;
- NextGen Midterm Concept of Operations v.2.0;
- RTCA Trajectory Operations Concept of Use



## **Performance Improvement Area 1: Greener Airports**

***Thread: Surface Operations***

This Page Intentionally Left Blank

## Module N° B0-75 Safety and Efficiency of Surface Operations (A-SMGCS Level 1-2)

<b>Summary</b>	Basic A-SMGCS provides surveillance and alerting of movements of both aircraft and vehicles on the aerodrome thus improving runway/aerodrome safety. ADS-B information is used when available (ADS-B APT)	
<b>Main Performance Impact</b>	KPA-1 Access and Equity; KPA-02 Capacity; KPA-04 Efficiency; KPA-05 Environment; KPA-10 Safety  KPA-4	
<b>Operating Environment / Flight Phases</b>	Aerodrome surface movements (aircraft + vehicles), taxi, push-back, parking	
<b>Applicability Considerations</b>	A-SMGCS is applicable to any aerodrome and all classes of aircraft/vehicles. Implementation to be based on requirements stemming from individual aerodrome operational and cost-benefit assessments.  ADS B APT is designed to be applied to aerodromes with medium traffic complexity, having up to two active runways at a time and the runway width of minimum 45 m.	
<b>Global Concept Component(s)</b>	AO – Aerodrome Operations CM – Conflict Management	
<b>Global Plan Initiatives (GPI)</b>	GPI-9 Situational Awareness GPI-13 Aerodrome Design and Management GPI-16 Decision Support Systems and Alerting Systems GPI-18 Electronic Information Services in the Global Plan Initiatives	
<b>Main Dependencies</b>	Linkage with B0-80 and B0-15	
<b>Global Readiness Checklist</b>		<b>Status</b> (indicate ready with a tick or input date)
	Standards Readiness	√
	Avionics Availability	√
	Infrastructure Availability	√
	Ground Automation Availability	√
	Procedures Available	√
	Operations Approvals	√

### 1. Narrative

#### 1.1 General

This module builds upon traditional SMGCS implementation (visual surveillance, aerodrome signage, lighting and markings) by the introduction of capabilities enhancing ATC situational awareness through:

- Display to the aerodrome controller of the position of all aircraft on the aerodrome movement area,
- Display to the aerodrome controller of all vehicles on the aerodrome manoeuvring area, and
- Generation of runway incursion alerts (where local operational, safety and cost-benefit analyses so warrant).

For A-SMGCS, the facilities and procedures also represent a significant improvement over and above performance levels associated to conventional SMGCS. The entire A-SMGCS concept, being based on a set of forward and backward compatible groupings of modular functionalities, will ensure these B0 facilities and procedures fully support seamless transitions to the more sophisticated facilities and procedures of A-SMGCS described in Blocks 1 and 2. The B0 level of implementation, corresponding to levels 1 and 2 of the A-SMGCS concept and being associated to the provision of ATS, is independent of aircraft equipage beyond that associated to cooperative surveillance equipage (e.g.: SSR Mode S or A/C transponders).

For ADS B APT the facilities and procedures will be the same with the performance levels associated to conventional SMGCS. The B0 level of implementation is dependent of aircraft/vehicle ADS B out equipage.

### **1.1.1 Baseline**

Surface operations historically have been managed by use of visual scanning by both ANSP personnel and flight crew, both as the basis for taxi management as well as aircraft navigation and separation. These operations are significantly impeded during periods of reduced visibility (weather obscuration, night) and high demand, e.g. when a large proportion of aircraft are from the same operator and/or of the same aircraft type. In addition, remote areas of the aerodrome surface are difficult to manage if out of direct visual surveillance. As a result, efficiency can be significantly degraded, and safety services are unevenly provided. Complementary to such historical means of aerodrome traffic management, enhanced surface situational awareness has been based upon use of an aerodrome surface movement primary radar system and display (SMR). This permits the surveillance of all aircraft and ground vehicles without any need for cooperative surveillance equipment installed on the aircraft/vehicles. This improvement allows ANSP personnel to better maintain awareness of ground operations during periods of low visibility. In addition, the presence of safety logic allows for limited detection of runway incursions.

### **1.1.2 Change brought by the module**

This module implements

- additional capabilities to the aerodrome surveillance environment by taking advantage of cooperative surveillance that provides the means to establish the position of all aircraft and vehicles and to specifically identify targets with individual flight/vehicle identification. Ground vehicles operating on the manoeuvring area will be equipped with cooperative surveillance transponders compatible with the specific A-SMGCS equipment installed so as to be visible to tower ground surveillance display systems.
- SMR like capabilities by implementing ADS-B APT on those aerodromes where surveillance is not available.

## **1.2 Element 1 – Surveillance**

In the case of A-SMGCS, this element of the block enhances the primary radar surface surveillance with the addition of at least one cooperative surface surveillance system. These systems include Multilateration, secondary surveillance radar Mode S, and Automatic Dependent Surveillance – Broadcast (ADS-B). As with TMA and En Route secondary surveillance radars/ADS-B, the cooperative aspect of the surveillance allows for matching of equipped surveillance targets with flight data, and also reduces clutter and degraded operation associated with primary surveillance. The addition of cooperative surveillance of aircraft and vehicles adds a significant positive benefit to the performance of safety logic, as the tracking and short-term trajectory projection capabilities are improved with the higher quality surveillance. The addition of this capability also provides for a marginal improvement in routine management of taxi operations and more efficient sequencing of aircraft departures.

In the case of ADS B APT this block provides controllers with traffic situational awareness on the movement areas. The provision of surveillance information to the controller will allow the deployment of SMGCS procedures, augmenting controller's situational awareness and helping the controller to manage the traffic in a more efficient way. In this respect, the ADS B APT application does not aim to reduce the occurrence of runway incursions, but may reduce the occurrence of runway collisions by assisting in the detection of the incursions.

**1.3 Element 2 – Alerting**

In the case of A-SMGCS, where installed and operated, alerting with flight identification information also improves the ATC response to situations that require resolution such as runway incursion incidents and improved response times to unsafe surface situations. Levels of sophistication as regards this functionality currently vary considerable among various industrial solutions being offered. B0 implementations will serve as important initial validation for improved algorithms downstream.

In the case of ADS B APT application a system generated alerting processes and procedures have not been defined (as this is considered premature at this development stage). It is possible that future variations of the ADS-B-APT application will assess the surveillance requirements necessary to support alerting functions.

**2. Intended Performance Operational Improvement/Metric to determine success**

<i>Access and Equity</i>	A-SMGCS: Improves access to portions of the manoeuvring area obscured from view of the control tower for vehicles and aircraft. Sustains an improved aerodrome capacity during periods of reduced visibility. Ensures equity in ATC handling of surface traffic regardless of the traffic’s position on the aerodrome.  ADS B APT: provides traffic situational awareness to the controller in the form of surveillance information. The availability of the data is dependent on the aircraft and vehicle level of equipage.
<i>Capacity</i>	A-SMGCS: Sustained levels of aerodrome capacity for visual conditions reduced to minima lower than would otherwise be the case.  ADS-B APT: potentially improve capacity for medium complexity aerodromes
<i>Efficiency</i>	A-SMGCS: Reduced taxi times through diminished requirements for intermediate holdings based on reliance on visual surveillance only. ADS-B APT: potentially reduce taxi times by providing improved traffic situational awareness to controllers
<i>Environment</i>	Reduced aircraft emissions stemming from improved efficiencies.
<i>Safety</i>	A-SMGCS: Reduced runway incursions. Improved response to unsafe situations. Improved situational awareness leading to reduced ATC workload.  ADS-B APT: potentially reduce the occurrence of runway collisions by assisting in the detection of the incursions

<i>CBA</i>	A-SMGCS: A positive CBA can be made from improved levels of safety and improved efficiencies in surface operations leading to significant savings in aircraft fuel usage. As well, aerodrome operators’ vehicles will benefit from improved access to all areas of the aerodrome, improving the efficiency of aerodrome operations, maintenance and servicing.  ADS B APT: less costly surveillance solution for medium complexity aerodromes
<i>Human Performance</i>	Reduced ATC workload. Improved ATC efficiencies.

**3. Necessary Procedures (Air & Ground)**

Procedures required to support B0 operations are those associated to the provision of the aerodrome control service. Flight crew procedures specific to A-SMGCS are not necessary beyond those associated with basic operation of aircraft transponder systems and settings of aircraft identification. Vehicle drivers will need to be in a position to effectively operate vehicle transponder systems.

ATC will be required to apply procedures specific to A-SMGCS for the purpose of establishing aircraft/vehicle identification. In addition, ATC will be required to apply procedures associated specifically to the use of A-SMGCS as a replacement to visual observation.

## **4. Necessary System Capability**

### **4.1 Avionics**

Existing aircraft ADS-B and/or SSR transponder systems, including correct setting of aircraft identification.

### **4.2 Vehicles**

Vehicle cooperative transponder systems, type as a function of the local A-SMGCS installation. Industry solutions readily available.

### **4.3 Ground systems**

A-SMGCS: The surface movement radar should be complemented by a cooperative surveillance means allowing to track aircraft and ground vehicles. A surveillance display including some alerting functionalities is required in the tower.

ADS B APT: cooperative surveillance infrastructure deployed on the aerodrome surface; installation of a tower traffic situational awareness display.

## **5. Human Performance**

### **5.1 Human Factors Considerations**

**5.1.1** Workload analyses will be necessary to ensure ATC can cope with increased aerodrome capacities in reduced visual conditions using A-SMGCS. ATC response to A-SMGCS generated runway incursion alarms and warnings will require human factors' assessments to ensure that ATC performance in this regard does in fact improve and not diminish. Human factors assessments will also be necessary for the assessment of the compatibility of A-SMGCS tower display installations with other tower surveillance display systems.

**5.1.2** Human Factors have been taken into consideration during the development of the processes and procedures associated with this module. Where automation is to be used, the Human-Machine interface has been considered from both a functional and ergonomic perspective (See Section 6 for examples). The possibility of latent failures however, continues to exist and vigilance is requested during all implementation actions. It is further requested that human factor issues, identified during implementation, be reported to the international community through ICAO as part of any safety reporting initiative.

### **5.2 Training and Qualification Requirements**

**5.2.1** Training in the operational standards and procedures are required for this module and can be found in the links to the documents in Section 8 to this module. Likewise, the qualifications requirements are identified in the regulatory requirements in Section 6 which form an integral part to the implementation of this module.

## **6. Regulatory/standardization needs and Approval Plan (Air & Ground)**

Standards approved for aerodrome multilateration, ADS-B and safety logic systems exist for use in Europe, the USA and other Member States. Standards for SMR exist for use globally.

## **7. Implementation and Demonstration Activities**

### **7.1 Current Use**

A-SMGCS responding to B0 functionality is already broadly deployed at a multitude of aerodromes globally. Several of those installations also include runway incursion alerting functionality, of varying degrees of sophistication and reliability.

### **7.2 Planned or on-going trials**

The US NextGen Programme are supporting deployment to additional aerodromes, using various combinations of primary and secondary surveillance. This includes low cost ground surveillance programs,

which may unite a more affordable primary radar system with ADS-B. In initial operational capabilities are expected in the 2012-2016 timeframe.

## 8. Reference Documents

### 8.1 Standards

- Community Specification on A-SMGCS Levels 1 and 2;
- ICAO Doc 9924, *Aeronautical Surveillance Manual*;
- ICAO Doc 9871, *Technical Provisions for Mode S Services and Extended Squitter*;
- ICAO Doc 9830, *Advanced Surface Movement Guidance and Control Systems (A-SMGCS) Manual*;
- ICAO Doc 7030/5, (EUR/NAT) *Regional Supplementary Procedures*, Section 6.5.6 and 6.5.7;
- FAA Advisory Circulars:
  - AC120-86 Aircraft Surveillance Systems and Applications
  - AC120-28D Criteria for Approval of Category III Weather Minima for Take-off, Landing, and Rollout
  - AC120-57A Surface Movement Guidance and Control System
- Avionics standards developed by RTCA SC-186/Eurocae WG-51 for ADS-B
- Aerodrome map standards developed by RTCA SC-217/Eurocae WG-44
- EUROCAE ED 163 Safety, Performance and Interoperability Requirements document for ADS B Airport Surface surveillance application (ADS-B APT)

### 8.2 ATC Procedures

- ICAO Doc 4444, *Procedures for Air Navigation Services — Air Traffic Management*; and
- ICAO Doc 7030, *Regional Supplementary Procedures* (EUR SUPPS).

### 8.3 Guidance material

- FAA NextGen Implementation Plan
- European ATM Master Plan

This Page Intentionally Left Blank



## Module N° B1-75: Enhanced Safety and Efficiency of Surface Operations (A-SMGCS/SURF-IA) and EVS

<b>Summary</b>	To provide enhancements to surface situational awareness, improving runway and taxiway safety, and surface movement efficiency. Cockpit improvements include the use of Surface Moving Maps with Traffic Information, basic runway safety alerting logic, and Enhanced Vision Systems (EVS) for low visibility taxi operations. Ground improvements include the means to track aircraft and ground vehicles, combined with safety logic to detect potential runway incursions.	
<b>Main Performance Impact</b>	KPA-10 Safety , KPA-4 Efficiency	
<b>Operating Environment / Phase of Flight</b>	Aerodrome operations	
<b>Applicability Considerations</b>	For SURF and SURF-IA, applicable to large aerodromes (ICAO codes 3 and 4) and all classes of aircraft; cockpit capabilities work independently of ground infrastructure, but other aircraft equipage and/or ground surveillance broadcast will improve benefit.	
<b>Global Concept Component(s)</b>	AO - Aerodrome Operations CM - Conflict Management	
<b>Global Plan Initiatives (GPI)</b>	GPI-9 Situational Awareness GPI-13 Aerodrome Design and Management GPI-16 Decision Support Systems and Alerting Systems GPI-18 Electronic Information Services	
<b>Pre-Requisites</b>	B0-75 (Surface Surveillance);	
<b>Global Readiness Checklist</b>		<b>Status</b> (indicate ready with a tick or input date)
	Standards Readiness	SURF ✓ /SURF-IA Est. 2015
	Avionics Availability	SURF Est. 2015-2017/SURF-IA Est. 2015-2017
	Infrastructure Availability	SURF N/A/SURF-IA N/A
	Ground Automation Availability	N/A
	Procedures Available	SURF 2013/SURF-IA Est. 2015
	Operations Approvals	SURF 2013/SURF-IA Est. 2015

### 1. Narrative

#### 1.1 General

This module builds upon the work completed in B0-75 Safety and Efficiency of Surface Operations (A-SMGCS Level 1-2) and cockpit moving map, by the introduction of new capabilities that enhance surface situational awareness and surface movement capabilities:

- Enhanced ANSP Surface Surveillance capability with Safety Logic
- Enhanced Cockpit Surface Surveillance capability with Indications and Alerts
- Enhanced Vision Systems for Taxi Operations

##### 1.1.1 Baseline

The baseline is the level of capability provided by Module B0-75 for the surface surveillance and the cockpit surface aspects.

For the vision element, the baseline is the crew's natural vision.

**1.1.2 Change brought by the module**

This module implements additional capabilities to the aerodrome surveillance capability by taking advantage of cooperative surveillance that provides a means to identify targets with specific flight identification. identification (SURF).The system can be enhanced by the addition of alerts to reduce the risk of collisions in runway operations (SURF-IA) . Cockpit operations receive a display of the surface map, with “ownship” and other traffic depicted. Cockpit visual scanning is further improved by the addition of Enhanced Vision Systems (EVS), which provides better visual awareness of surroundings during periods of reduced visibility (e.g. night, weather obscuration). In addition, ground vehicles operating in the movement area will be equipped initially to be visible to tower and cockpit systems, and eventually be equipped with map and traffic capabilities similar to the cockpit.

**1.1 Element 1: Basic Surface Situation Awareness (SURF) and Enhanced Traffic Situational Awareness on the Surface of Airport with Indications and Alerts (SURF-IA)**

Initial enhancements allow for other aerodrome traffic to be depicted on the display (SURF). This information may be direct aircraft-to-aircraft (e.g., via ADS-B In avionics on the own ship combined with ADS-B Out avionics on other aircraft), or may be provided via a Traffic Information Service-Broadcast (TIS-B) from the ANSP based on ANSP surveillance.

The final enhancement to cockpit capability is the addition of safety logic to the avionics, which allows for detection of potential unsafe situations (e.g. runway already occupied) independent of any ground system, the presentation of these situations (e.g., by highlighting the occupied runway), and by providing a visual and aural alert.

The addition of traffic depictions on cockpit electronic maps, further enhanced by safety logic, provides enhanced redundancy for the detection of potentially unsafe situations. Also, this capability provides for a marginal improvement surface efficiency, as there will be improved situational awareness of taxi routes, especially at aerodromes unfamiliar to the flight crew.

These capabilities could also be applied to support drivers of equipped ground vehicles.

**1.2 Element 2: Enhanced Vision Systems for Taxi Operations**

Additional avionics add electromagnetic sensors outside the visible light spectrum (e.g. infrared cameras, Millimeter Wave Radar). These sensors will allow for improved navigation by visual reference, even during conditions of low-light or weather obscuration such as fog. Presentation to the flight crew may be through an instrument panel display (Liquid Crystal Display or Cathode Ray Tube) or via Heads-Up Display (HUD), etc.

The addition of cockpit enhanced vision capabilities will improve flight crew awareness of ownship position, and reduce navigation errors during periods of reduced visibility. In addition, improved situational awareness of aircraft position will allow for more confidence by the flight crew in the conduct of the taxi operation during periods of reduced visibility.

**2. Intended Performance Operational Improvement**

Metrics to determine the success of the module are proposed at Doc 9883

<i>Efficiency</i>	Element 1: Reduced Taxi Times Element 2: Fewer navigation errors requiring correction by ANSP
<i>Safety</i>	Element 1: Reduced risk of collisions Element 1: Improved response times to correction of unsafe surface situations (SURF-IA only). Element 2: Fewer navigation errors
<i>CBA</i>	The business case for this element can be largely made around safety. Currently, the aerodrome surface is often the regime of flight which has the most risk for aircraft safety, due to the lack of good surveillance on the ground acting in redundancy with cockpit capabilities. Visual scanning

	<p>augmentation in the cockpit acting in conjunction with service provider capabilities enhances operations on the surface. Efficiency gains are expected to be marginal and modest in nature.</p> <p>Improving flight crew situational awareness of own-ship position during periods of reduced visibility will reduce errors in the conduct of taxi operations, which lead to both safety and efficiency gains.</p>
--	---

### 3. Necessary Procedures (Air & Ground)

When implementing SURF or SURF-IA, adherence to aircraft flight manual approved procedures for the use of the equipment is required.

These procedures outline limitations to the use of the equipment and the proper incorporation of new capabilities into the existing taxi procedures and techniques (e.g. appropriate heads-up and heads-down times, integration with effective Cockpit Resource Management, etc.). Flight crew response to alerting capabilities requires incorporation into appropriate initial and recurrent training.

The procedure for the use of ADS-B traffic display is being proposed for inclusion in the PANS OPS Doc8168) for applicability in Nov. 2013. (SURF)

The procedure for the use of Indications and Alerts will be developed for inclusion in the PANS-OPS (and possibly in the PANS-ATM)(SURF-IA).

Drivers of ground vehicles in the movement area equipped with surface situational awareness and alerting capabilities will require similar procedures for use, including initial and recurrent training.

The addition of enhanced vision systems for taxi operations requires adherence to aircraft flight manual approved procedures for the use of the equipment.

### 4. Necessary System Capability

#### 4.1 Avionics

The aircraft choosing to equip for operating in this environment will add basic surface situation awareness (SURF) and enhanced traffic situational awareness on the airport surface with indications and alerts (SURF-IA) including ADS-B/traffic information service broadcast receiver (SURF), and runway safety logic (SURF-IA). ADS-B Out avionics will be required for direct aircraft-to-aircraft surveillance.

These capabilities could also be applied to support drivers of equipped ground vehicles.

With the addition of enhanced vision systems for use during taxi operations, an enhanced flight vision system in the aircraft will be required.

#### 4.2 Ground Systems

For SURF, no ground system is required. For SURF-IA, it is essential to have a complete traffic situation on the runway and either a mandatory carriage of ADS-B OUT and/or TIS-B ground stations, are required.

Some of these more advanced technologies may require compatible runway/taxiway lighting on the aerodrome surface in particular to accommodate the avionics.

### 5. Human Performance

#### 5.1 Human Factors Considerations

Human performance is a critical aspect in resolving runway incursions; it must be accounted for in avionics system design to determine how far in advance of the predicted runway incursion or other factor the system must identify so that flight crew action can be taken to avoid it.

## 5.2 Training and Qualification Requirements

Since automation support is needed for the pilots, they therefore have to be trained to the new environment and to identify the aircraft which can accommodate the expanded services available in particular when operating in a mixed mode environment.

## 6. Regulatory/standardization needs and Approval Plan (Air & Ground)

Regulatory/Standardization: Use current published criteria that include the material given in Section 8.1 and 8.4

Approval Plans: No new or updated approval criteria are needed at this time. Implementation plans should reflect available aircraft, ground systems and operational approvals.

Standards require those for aerodrome multilateration systems, [ADS-B](#) ground systems, and Safety Logic, which have been approved for operational use in the Europe, the US and other member states. Guidance on these systems can be found in the ICAO Surveillance Multilateration Manual.

Avionics standards developed by RTCA SC-186/Eurocae WG-51 for ADS-B, and aerodrome map standards developed by RTCA SC-217/Eurocae WG-44, are applicable for this element.

## 7. Implementation and Demonstration Activities

### 7.1 Current Use

The US and Europe already developed standards for SURF. They are in the process of defining avionics standards for SURF-IA, with operational capabilities expected to be phased in now through 2017. Standards are in development for ground vehicle equipment to allow them to be "seen" via ADS-B.

Certification of Enhanced Flight Vision Systems for aerodrome surface operations have been accomplished for several aircraft types by several member States as of this writing (e.g. Dassault Falcon 7X, Gulfstream GVI, Bombardier Global Express).

### 7.2 Planned or Ongoing Trials

As part of the ATSAW Pioneer Project sponsored by EUROCONTROL in 2012, SURF is one of the applications evaluated with revenue aircraft. In the first step, focus is put on AIRB and ITP but SURF is planned to be evaluated in a second step.

Similar trials are planned in the US with US Airways by 2013.

## 8. Reference Documents

### 8.1 Standards

- ICAO Surveillance Multilateration Manual;
- ICAO Doc 7030/5, (EUR/NAT) *Regional Supplementary Procedures*, Section 6.5.6 and 6.5.7;
- ICAO Doc 9830, *Advanced Surface Movement Guidance and Control Systems (A-SMGCS) Manual*
- European Union, OJEU [2010/C 330/02](#): Community Specification ETSI EN 303 213-4-2 v.1.1.1: European Standard (Telecommunications series) Advanced Surface Movement Guidance and Control System (A-SMGCS); Part 4: Community Specification for application under the Single European Sky Interoperability Regulation EC 552/2004 for a deployed non-cooperative sensor including its interfaces; Sub-part 2: Specific requirements for a deployed Surface Movement Radar sensor
- FAA Advisory Circular, AC120-86, Aircraft Surveillance Systems and Applications
- FAA Advisory Circular, AC120-28D, Criteria for Approval of Category III Weather Minima for Take-off, Landing, and Rollout
- FAA Advisory Circular, AC120-57A Surface Movement Guidance and Control System
- EUROCAE ED-98A / RTCA DO-276A, User requirements for Terrain and Obstacle Data
- EUROCAE ED-99C / RTCA DO-272C, User Requirements for Aerodrome Mapping Information

- EUROCAE ED-119B / RTCA DO-291B, Interchange Standards for Terrain, Obstacle, and Aerodrome Mapping Data
- EUROCAE ED-102A / RTCA DO-206B, MOPS for 1090 MHz Extended Squitter Automatic Dependant Surveillance – Broadcast (ADS-B) & Traffic Information Services – Broadcast (TIS-B)
- EUROCAE ED-126 / RTCA DO-303, Safety, Performance and Interoperability Requirements Document for the ADS-B Non-Radar-Airspace (NRA) Application
- EUROCAE ED-163 / RTCA DO-321, Safety, Performance and Interoperability Requirements Document for ADS-B Airport Surface Surveillance Application (ADS-B-APT)
- EUROCAE ED-165 / RTCA DO-322, Safety, Performance and Interoperability Requirements Document For ATSA-SURF Application
- EUROCAE ED-194 / RTCA DO-317A, Minimum Operational Performance Standards (MOPS) for Aircraft Surveillance Applications (ASA) System
- EUROCAE ED-195 / RTCA DO-328, Safety, Performance and Interoperability Requirements Document for Airborne Spacing – Flight Deck Interval Management (ASPA-FIM).

### **8.2 Procedures**

- Much is contained in other guidance materials.

### **8.3 Guidance Material**

- FAA NextGen Implementation Plan;
- European ATM Master Plan.

### **8.4 Approval Documents**

- ICAO Doc 4444, *Procedures for Air Navigation Services — Air Traffic Management*;
- ICAO Flight Plan Classification;
- EASA Community Specification on A-SMGCS Levels 1 and 2;
- ICAO Surveillance Multilateral Manual;
- ICAO Doc 9830, *Advanced Surface Movement Guidance and Control Systems (A-SMGCS) Manual*
- ICAO Doc 7030/5, (EUR/NAT) *Regional Supplementary Procedures*, Section 6.5.6 and 6.5.7
- FAA Advisory Circulars:
  - AC120-86 Aircraft Surveillance Systems and Applications;
  - AC120-28D Criteria for Approval of Category III Weather Minima for Take-off, Landing, and Rollout;
  - AC120-57A Surface Movement Guidance and Control System.

This Page Intentionally Left Blank

## Module N° B2-75: Optimized Surface Routing and Safety Benefits (A-SMGCS Level 3-4 and SVS)

<b>Summary</b>	To improve efficiency and reduce the environmental impact of surface operations, even during periods of low visibility. Queuing for departure runways is reduced to the minimum necessary to optimize runway use and taxi times are also reduced. Operations will be improved so that low visibility conditions will have a minor effect on surface movement.	
<b>Main Performance Impact</b>	KAP-01 Access and Equity; KPA-04 Efficiency, KPA-06 Flexibility; KPA-10 Safety	
<b>Operating Environment / Flight Phases</b>	Aerodrome	
<b>Applicability Considerations</b>	Most applicable to large aerodromes with high demand, as the upgrades address issues surrounding queuing and management and complex aerodrome operations	
<b>Global Concept Component(s)</b>	AO - Aerodrome Operations CM - Conflict Management DCB - Demand Capacity Balancing TS - Traffic Synchronization	
<b>Global Plan Initiatives (GPI)</b>	GPI-14 Runway Operations GPI-16 Decision Support Systems and Alerting Systems GPI-17 Data Link Applications GPI-18 Electronic Information Services	
<b>Main Dependencies</b>	B1-75, and B1-40 Technical or operational relationship to: B2-80 (Remote Tower)	
<b>Global Readiness Checklist</b>		<b>Status</b> (indicate ready with a tick or input date)
	Standards Readiness	Est. 2018-2023
	Avionics Availability	Est. 2018-2023
	Infrastructure Availability	Est. 2018-2023
	Ground Automation Availability	Est. 2018-2023
	Procedures Available	Est. 2018-2023
	Operations Approvals	Est. 2018-2023

### 1. Narrative

#### 1.1 General

This module is focused on improving the baseline case (completion of B0-75, Improved Runway Safety (A-SMGCS Level 1-2 and Cockpit Moving), by the introduction of new capabilities that enhance the coordination among ANSP, Airspace Users, and the Aerodrome Operator, and permit automated management of surface operations:

- Initial Surface Traffic Management (A-SMGCS Level 3)
- Enhanced Surface Traffic Management (A-SMGCS Level 4)
- Enhanced Cockpit Surface Surveillance Capability with Indications and Alerts
- Synthetic Vision Systems

This module assumes that a cooperative aircraft surveillance capability is in operational use at aerodromes, and that air navigation service provider (ANSP) and flight crews have access to surveillance and safety logic. This enhances the common situational awareness between the ANSP and Flight Crew.

### 1.1.1 Baseline

The baseline for this module is the level of capability achieved by B1-75, with the combination of A-SMGCS levels 1 and 2 and airport surface surveillance with safety logic for ANSPs and flight crews, as well as moving map displays and enhanced vision systems for taxi operations.

Globally, aerodrome operations have typically been handled in an ad hoc manner, in that decision-making regarding the pushback of aircraft from aprons into the movement area have been made almost entirely by the airspace user. When consideration of the air traffic management (ATM) system in pushback is included, it has been limited to manual coordination of Air Traffic Flow Management (ATFM), not the aerodrome operation itself. As a result, taxiway congestion and departure queues form which extend taxi times, increase direct operating costs (excess fuel burn), impact environment (emissions), and impede the efficient implementation of ATFM plans.

### 1.1.2 Change brought by the module

This module implements additional surface traffic management (A-SMGCS Level 3) capabilities which include the ability for a basic aerodrome taxi schedule to be created. This is based on scheduled flights, with updates and additions provided by initial data sharing of flight status from Airspace Users and/or Airport Operators (e.g. ramp tower, airspace user aerodrome operations, airspace user dispatch office, etc.). A basic capability to manage departure queues is also provided. Flight Deck operations include the ability to receive taxi clearances via data link communications.

This module also extends to enhance the surface traffic management to an A-SMGCS Level 4 capability which includes the ability to create a more accurate aerodrome taxi schedule, including development of taxi trajectories (i.e. including times at points along the taxi path). The taxi schedule is integrated with ANSP arrival management and departure management capabilities, to improve execution of overall Air Traffic Flow Management strategies. Flight Deck operations are enhanced by taxi route guidance and synthetic vision displays.

All of these capabilities combine to lessen the impact of reduced visibility conditions on aerodrome operations, as visual scanning is augmented by the presence of situational awareness, safety logic, and guidance and monitoring of aircraft taxi paths and trajectories. These capabilities also support the expanded use of Virtual or Remote towers as described in the B1-81 module.

These capabilities will include changes to ANSP, airspace user and airport operations, and flight deck operations..

### 1.3 Element 1: Initial Surface Traffic Management (A-SMGCS Level 3)

This element of the block includes the following capabilities:

- Taxi Routing Logic for ANSP – automation provides suggested taxi routes based on current aircraft position and heuristics. These rules take into consideration the departure route, the departure runway usually associated with the departure route, and most efficient paths to the runway
- Detection of Conflicting ATC clearance for ANSP – automation considers the existing surface operation and active clearances, and detects if conflicts arise in ATC clearances as the surface situation changes.
- Data Link Delivery of Taxi Clearance – the taxi clearance is provided digitally to aircraft
- Conformance Monitoring of ATC Clearance for ANSP – automation monitors the movement of aircraft on the surface and provides an alert if aircraft deviate from their assigned ATC clearance
- Basic Taxi Schedule - automation builds a projected schedule for the surface based on scheduled flights. This schedule is modified as airspace users update their projections for when flights will be actually ready for pushback.
- Aggregate Departure Queue Management – if congestion is predicted on the taxi schedule (e.g. excessive queues are predicted to form), then airspace users will be assigned a target number of flights that will be permitted to begin taxi operations over a future parameter time period; airspace users may choose their own priorities for assigning specific flights to these taxi opportunities. This



capability will have basic ability to incorporate any Air Traffic Flow Management Constraints to specific flights.

- Data Sharing – information about taxi times, queues, and delays is shared with other ANSP flight domains, and with external users (airspace users and airport operators).
- Improved Guidance by use of Aerodrome Ground Lighting – ground lighting systems on the aerodrome are enhanced to provide visual cues to aircraft operating on the surface.

These activities are intended to directly improve efficiency by maximizing runway use while minimizing taxi times, within the context of any higher level Air Traffic Flow Management strategy and available airport resources (e.g. gates, apron areas, stands, taxiways, etc.). This will result in reduced fuel burn, with associated lowering of environmental impacts.

Further, data sharing will improve the information available to Air Traffic Flow Management, leading to better coordination and decision making among ANSP and airspace users. A secondary impact of this element will be improved safety, as conformance to taxi clearance is monitored. Aircraft will receive taxi clearances digitally, to further reduce potential confusion about taxi routes. These capabilities also lessen the impact of reduced visibility conditions on the aerodrome operation.

**1.4 Element 2: Enhanced Surface Traffic Management (A-SMGCS Level 4)**

This element of the block enhances capabilities from Element 1:

- Taxi Trajectories – automation builds a predicted trajectory for each aircraft including times along the taxi path. When this capability matures, taxi trajectories will be used to assist with deconflicting runway crossings. Conformance monitoring is enhanced to monitor against trajectory times in addition to paths, with prediction and resolution of taxi trajectory conflicts.
- Taxi Trajectory Guidance for Pilots – digital taxi clearances are parsed by the aircraft avionics to allow depiction of the taxi route on surface moving maps. Avionics may be further enhanced to provide visual and/or aural guidance cues for turns in the taxi route, as well as taxi speed guidance to meet surface trajectory times. This can be displayed on the instrument panel or on a Heads-Up Display.
- Synthetic Vision Systems – area navigation capability on the aircraft and detailed databases of aerodromes will allow for a computer-synthesized depiction of the forward visual view to be displayed in the cockpit. Integration with Enhanced Vision System will add integrity to this depiction. This capability reduces the impact that low visibility conditions have on the safety and efficiency of the surface operation. The depiction can be displayed on the instrument panel or on a Heads-Up Display.
- Flight-Specific Departure Schedule Management – ANSP and airspace users will collaboratively develop a flight-specific surface schedule. Automation assists in identifying appropriate departure times that consider any Air Traffic Flow Management actions. Other operational factors such as wake turbulence separation requirements will be considered by automation in sequencing aircraft for departures. Pushback and taxi operations will be managed to this schedule.
- Integration with Arrival and Departure Management – taxi schedules are built to account for arriving aircraft, and so that aircraft departures meet the objectives for system-wide Air Traffic Flow Management activities. Flight will be permitted to pushback with the intent to meet targeted departure times.

**1.5 Element 3: Synthetic Vision Systems**

The addition of synthetic vision capabilities will further improve flight crew awareness of ownship position, and reduce navigation errors during periods of reduced visibility, and allow for more confidence by the flight crew in the conduct of the taxi operation during periods of reduced visibility

**2. Intended Performance Operational Improvement / Metric to determine success**

<i>Access and Equity</i>	This activity contributes to airport access during periods of reduced visibility, by augmenting visual scanning in the tower and in the cockpit by a common surveillance picture, safety logic, and taxi routing,
--------------------------	---

	conformance, and guidance. The impact of visual obscuration and night operations on aerodrome operations is lessened.
<i>Efficiency</i>	<p>These activities are intended to further improve taxi efficiency by managing by trajectory both in the tower and in the cockpit. This allows aircraft to stay in motion for longer periods during the taxi operation, reducing the taxi times and associated fuel burn even further. Coordination of schedules among arrivals, surface, and departures further enhances the efficiency of operations.</p> <ul style="list-style-type: none"> <li>a. Reduced Taxi Out Times             <ul style="list-style-type: none"> <li>i. Reduced fuel burn and other direct operating cost</li> <li>ii. Associated reduced impact to environment</li> </ul> </li> <li>b. Reduced Start/Stop of during Taxi             <ul style="list-style-type: none"> <li>iii. Reduced fuel burn and other direct operating cost</li> <li>iv. Associated reduced impact to environment</li> </ul> </li> </ul>
<i>Flexibility</i>	<ul style="list-style-type: none"> <li>a. Improved ability to re-sequence departing aircraft to meet changing conditions</li> <li>b. Coordination with Air Traffic Flow Management             <ul style="list-style-type: none"> <li>i. Improved ability to predict congestion (actual demand vs. capacity)</li> </ul> </li> <li>a. Improved application of Air Traffic Flow Management by trajectory</li> <li>b. Improved Information to Air Traffic Flow Management             <ul style="list-style-type: none"> <li>i. Improved ability to predict congestion (actual demand vs. capacity)</li> <li>ii. Improved application of Air Traffic Flow Management Actions</li> </ul> </li> <li>c. Improved flexibility on the aerodrome surface by improving the ability to re-sequence departing aircraft to meet changing conditions</li> </ul>
<i>Safety</i>	<p>This element improves the safety of surface operations, by adding taxi route guidance and trajectory conformance capabilities to the aircraft. This will further reduce navigation errors on the surface, and will provide a means for further deconfliction of path intersections such as runway crossings. Aerodrome operations are less affected by low visibility conditions.</p> <ul style="list-style-type: none"> <li>a. Reduced Taxi Non-Conformance</li> <li>b. Reduced Taxi Clearance Communications Errors</li> </ul>
<i>CBA</i>	<p>The business case for this element is based on minimizing taxi times, thus reducing the amount of fuel burned during the taxi operation. Air Traffic Flow Management delays are taken at the gate, stands, apron, and taxiway holding areas rather than in queues at the departure end of the runway. Runway utilization will be maintained so as to not impact throughput.</p>

### 3. Necessary Procedures (Air & Ground)

Significant ANSP procedures changes for managing aerodrome surface operations will be required, including the creation of collaboration procedures and norms with airspace users and/or aerodrome operators for aggregate surface scheduling. In particular, managing surface operations by ANSP control of pushback times is potentially a significant change in aerodrome management policies at many locations. Specific procedures for each element and sub-element are required to effectively achieve the benefits of this module, and ensure safety, including procedures for ANSP use of Data Link Taxi Clearances and procedures for coordination with Air Traffic Flow Management.

Airspace users and/or aerodrome operators need to make significant changes to their procedures for managing surface operations, especially for the collaborative building of aggregate surface taxi schedules and the accommodation of ANSP control of pushback times.

Flight deck procedures for use and integration of Data Link Taxi Clearances are required.

## 4. Necessary System Capability

### 4.1 Avionics

In addition to the aircraft equipage required by B1-75 (ATSA(SURF-IA,)) the following aircraft technology is required:

1. Data Link Communications
2. Synthetic Vision System
3. Taxi Trajectory Guidance capability

### 4.2 Ground Systems

The following ANSP technology is required:

1. Initial and enhanced A-SMGCS / Surface Traffic Management Automation
2. Data sharing with Air Traffic Flow Management
3. Data Link Communications.

This element also requires an airspace user/aerodrome operator technology deployment in the form of an Enhanced A-SMGCS / Collaboration capability with ANSP Surface Traffic Management capability.

## 5. Human Performance

### 5.1 Human Factors Considerations

Since ground operations procedural changes for managing aerodrome surface operations will be required, including the creation of collaboration procedures and norms with airspace users and/or aerodrome operators for aggregate surface scheduling, human factors must be considered and demonstrated during the planning process. Human factors must also be considered in the context of workload and failure modes to ensure safety, including procedures for ANSP use of Data Link Taxi Clearances.

Human factors in the form of workload analysis must also be considered for airspace users and/or aerodrome operators when they make significant changes to their procedures for managing surface operations, especially for the collaborative building of aggregate surface taxi schedules and the accommodation of ANSP control of pushback times.

Additional studies must be completed as to the effects of changes in flight deck procedures for use and integration of Data Link Taxi Clearances.

### 5.2 Training and Qualification Requirements

**5.2.1** Automation and procedural changes for aircrews, controllers, ramp operators, etc. will invoke necessary training for the new environment and to identify operational and automation issues before implementation. Scenarios will also have to be developed and trained that incorporate likelihood of occurrences of off nominal situations so the full capability of this module can be implemented.

## 6. Regulatory/Standardization needs and Approval Plan (Air & Ground)

Regulatory/Standardization: New or updated criteria and standards are needed that includes:

- Initial and Enhanced A-SMGCS / Surface Traffic Management Automation
- Communication standards with Air Traffic Flow Management and Airspace User and/or Aerodrome Operators (aggregate collaboration on schedule, (integration of arrival, surface, and departure schedules)
- Data Link Communications
- Flight Deck Taxi Trajectory Guidance
- Flight Deck Synthetic Vision Systems (RTCA SC-213/EUROCAE WG-79).

Approval Plans: To Be Determined

## 7. Implementation and Demonstration Activities

### 7.1 Current Use

#### 7.1.1 Initial Surface Traffic Management (A-SMGCS Level 3)

ANSPs and commercial companies have developed initial capabilities in this area. These capabilities allow for data exchange of surface surveillance data between ANSPs, airspace users, and airport operators. Enhancements to operations are largely centered on improvements that shared surface situational awareness provides.

#### 7.1.2 Enhanced Surface Traffic Management (A-SMGCS Level 4)

The operations of this Element are still under research, and have not yet been implemented in current use.

### 7.2 Planned or Ongoing Trials

#### 7.2.1 Initial Surface Traffic Management (A-SMGCS Level 3)

Various ANSPs, research and government organizations and industry are working on prototype capabilities of Surface Traffic Management. These activities include Surface Traffic Management / Airport Collaborative Decision Making capabilities and concepts under evaluation at airports around the world (e.g. Memphis, Dallas-Fort Worth, Orlando, Brussels, Paris/Charles de Gaulle, Amsterdam, London/Heathrow, Munich, Zurich, and Frankfurt). Laboratory simulation experiments on more advanced capabilities such as Taxi Conformance Monitoring (MITRE) have been performed. European development is being accomplished via SESAR Work Package 6, EUROCONTROL, and others. Deployment in the United States of initial capabilities is slated for the 2018 timeframe.

#### 7.2.2 Enhanced Surface Traffic Management (A-SMGCS Level 4)

Collaborative Departure Scheduling is under research in the United States by the FAA, but has not yet undergone operational trials. Laboratory simulation experiments on more advanced capabilities such as Taxi Route Guidance (NASA) have been performed. Other areas such as management of aerodrome surface operations by trajectory are still under concept formulation. Operational deployment in the United States of capabilities is slated for beyond 2018.

## 8. Reference Documents

### 8.1 Standards

- EUROCAE ED-100A / RTCA DO-258A, Interoperability Requirements for ATS Applications using ARINC 622 Data Communications
- EUROCAE ED-110 / RTCA DO-280, Interoperability Requirements Standard for Aeronautical Telecommunication Network Baseline 1 (Interop ATN B1)
- EUROCAE ED-120 / RTCA DO-290, Safety and Performance Requirements Standard For Initial Air Traffic Data Link Services In Continental Airspace (SPR IC)
- EUROCAE ED-122 / RTCA DO-306, Safety and Performance Standard for Air Traffic Data Link Services in Oceanic and Remote Airspace (Oceanic SPR Standard)
- EUROCAE ED-154 / RTCA DO-305, Future Air Navigation System 1/A – Aeronautical Telecommunication Network Interoperability Standard (FANS 1/A – ATN B1 Interop Standard)
- EUROCAE WG78/RTCA SC214 Safety and Performance requirements and Interoperability requirements.

### 8.2 Procedures

To be determined.

### 8.3 Guidance Material

- ICAO Doc 9694, *Manual of Air Traffic Services Data Link Applications*;
- ICAO Doc 9830, *Advanced Surface Movement Guidance and Control Systems (A-SMGCS) Manual*;

#### **8.4 Approval Documents**

- FAA Advisory Circular, AC120-28D Criteria for Approval of Category III Weather Minima for Take-off, Landing, and Rollout
- FAA Advisory Circular, AC120-57A Surface Movement Guidance and Control System

#### **New updates and material is needed for the following:**

- Initial and Enhanced A-SMGCS / Surface Traffic Management Automation;
- Communication standards with Air Traffic Flow Management and Airspace User and/or Aerodrome Operators (aggregate collaboration on schedule, (integration of arrival, surface, and departure schedules);
- Data Link Communications;
- Flight Deck Taxi Trajectory Guidance;
- Flight Deck Synthetic Vision Systems (RTCA SC-213/EUROCAE WG-79).

This Page Intentionally Left Blank

## Performance Improvement Area 1: Greener Airports

*Thread: Airport [Collaborative Decision Making](#)*

This Page Intentionally Left Blank



## Module N° B0-80: Improved Airport Operations through Airport-CDM

<b>Summary</b>	To implement collaborative applications that will allow the sharing of surface operations data among the different stakeholders on the airport. This will improve surface traffic management reducing delays on movement & manoeuvring areas and enhance safety, efficiency and situational awareness.	
<b>Main Performance Impact</b>	KPA-02 capacity; KPA-04 – Efficiency; KPA-05 – Environment;	
<b>Operating Environment/Phases of Flight</b>	Aerodrome, Terminal	
<b>Applicability Considerations</b>	Local for equipped/capable fleets and already established airport surface infrastructure.	
<b>Global Concept Component(s)</b>	AO – Airport Operations IM – Information Management	
<b>Global Plan Initiatives (GPI)</b>	GPI-8 Collaborative airspace design and management GPI-18 Aeronautical information GPI-22 Communication infrastructure	
<b>Pre-Requisites</b>	Linkage with B0-75 and B0-15	
<b>Global Readiness Checklist</b>		<b>Status</b> (ready now or estimated date).
	Standards Readiness	Est. 2013
	Avionics Availability	√
	Ground System Availability	Est. 2013
	Procedures Available	Est. 2013
	Operations Approvals	Est. 2013

### 1. Narrative

#### 1.1 General

##### 1.1.1 Baseline

Surface operations, especially for the turnaround phase, involve all operational stakeholders at an airport. They all have their processes that they try to conduct as efficiently as possible. However, by relying on separated systems and not sharing all relevant information, they currently do not perform as efficiently as they could.

The baseline will be operations without airport collaboration tools and operations.

##### 1.1.2 Change brought by the module

Implementation of airport collaborative decision making (A-CDM) will enhance surface operations and safety by making airspace users, ATC and airport operations better aware of their respective situation and actions on a given flight.

Airport-CDM is a set of improved processes supported by the interconnection of various airport stakeholders' information systems. Airport-CDM can be a relatively simple, low cost programme.

## 2. Intended Performance Operational Improvement

Metrics to determine the success of the module are proposed in the *Manual on Global Performance of the Air Navigation System (Doc 9883)*.

<i>Capacity</i>	Enhanced use of existing infrastructure of gate and stands (unlock latent capacity) Reduced workload, better organisation of the activities to manage flights
<i>Efficiency</i>	Increased efficiency of the ATM system for all stakeholders. In particular for aircraft operators: improved situational awareness (aircraft status both home and away), enhanced fleet predictability & punctuality, improved operational efficiency (fleet management) & reduced delay
<i>Environment</i>	<ul style="list-style-type: none"> <li>• Reduced taxi time</li> <li>• Reduced Fuel and Carbon Emissions</li> <li>• Lower aircraft engine run time</li> </ul>

<a href="#">CBA</a>	The business case has proven to be positive due to the benefits that flights and the other airport operational stakeholders can obtain. However this may be influenced depending upon the individual situation (environment, traffic levels investment cost etc)  A detailed business case has been produced in support of the EU Regulation which was solidly positive.
---------------------	--

## 3. Necessary Procedures (Air & Ground)

The existing procedures need to be adapted to the collaborative environment in order to provide full benefits. These changes will affect the way the pilot, controller, airlines operations and ATFM unit will exchange information and manage the departing queue. The pushback and engine start up are just in time taking in account assigned runway, taxiing time, runway capacity, departure slot and departure constraints.

## 4. Necessary System Capability

### 4.1 Avionics

No airborne equipment is required.

### 4.2 Ground Systems

CDM does not require specific new functionalities. The difficulty is more to interconnect ground systems depending on the systems in place locally, but experience proves that industrial solutions/support exist. Where available, shared surveillance information may enhance operations.

## 5. Human Factors

### 5.1 Human Factors Considerations

**5.1.1** Human Factors have been taken into consideration during the development of the processes and procedures associated with this module. Where automation is to be used, the Human-Machine interface has been considered from both a functional and ergonomic perspective (See Section 6 for examples). The possibility of latent failures however, continues to exist and vigilance is requested during all implementation actions. It is further requested that human factor issues, identified during implementation, be reported to the international community through ICAO as part of any safety reporting initiative.

### 5.2 Training and Qualification Requirements

**5.2.1** Training in the operational standards and procedures are required for this module and can be found in the links to the documents in Section 8 to this module. Likewise, the qualifications requirements are identified in the regulatory requirements in Section 6 which form an integral part to the implementation of this module

## 6. Regulatory/standardization needs and Approval Plan (Air and Ground)

- Regulatory/Standardization: Updates required to the following current published criteria:
  - ICAO Doc 4444, *Procedures for Air Navigation Services — Air Traffic Management*;
  - ICAO CDM Manual.
- Approval Plans: Updates required for:
  - Eurocontrol, [A-CDM Implementation Manual](#); and
  - FAA NextGen Implementation Plan.

## 7. Implementation and Demonstration Activities

### 7.1 Current Use

**Europe:** EUROCONTROL Airport CDM has both developed and trialled a number of Airport CDM elements and is currently proactively encouraging European airports to implement Airport CDM locally. Airport CDM is not just a system, hardware or software, meeting or telephone call; it involves culture change, handling of sensitive data, procedural changes and building confidence and understanding of each partners operational processes.

With the help of airport stakeholders the European Airport CDM concept has matured significantly over the years from a high level concept into a process that is delivering real operational benefits. More and more airports are currently implementing Airport CDM and being rewarded by the proven benefits.

With Airport CDM implemented locally at an airport the next steps are to enhance the integration of airports with the Air Traffic Flow & Capacity Management (ATFCM) network and the Central Flow Management Unit (CFMU).

Exchange of real time data between airports and CFMU is operational. The accuracy of this data is proving to be very beneficial to both the CFMU and airports. The airports are receiving very accurate arrival estimates for all flights via the Flight Update Message (FUM). The CFMU is benefiting with enhanced take off time estimates in tactical operations via the Departure Planning Information (DPI) messages. A number of additional airports will enter into the data exchange with the CFMU over the coming months.

Based on the successful implementation of FUM/DPI at Munich airport (operational since June 2007) and the outcome of live trials in Zurich, Brussels, and other airports in close coordination with the CFMU, the objective is to develop incentives for all airport stakeholders to adopt the new procedures and take advantage of the proven benefits.

All information is at: [http://www.EUROCONTROL.int/airports/public/standard\\_page/APR2\\_ACDM\\_2.html](http://www.EUROCONTROL.int/airports/public/standard_page/APR2_ACDM_2.html), and <http://www.euro-cdm.org/>.

In October 2008, ACI EUROPE and EUROCONTROL signed a collaboration to increase operational efficiencies at European airports based on the implementation of [A-CDM](#). In 2009-10, the A-CDM programme has made great progress with more than 30 airports engaged in implementing, and the target to have [A-CDM](#) fully implemented at 10 airports by the end of 2011.

A formal accreditation to an A-CDM label has been created, already granted to Munich, Brussels and Paris-[CDG](#) airports.

## 7.2 *Planned or Ongoing Trials*

**United States:** The Collaborative Departure Queue Management CDS concept will be evaluated in field tests by the FAA during the Surface Trajectory Based Operations (STBO) projects in 2011.

To evaluate the Human-in-the-Loop system's feasibility and benefits, five airline dispatchers from American carriers: Continental, Delta, JetBlue, Southwest, and United Airlines used the system to manage a set of flights through several simulated air traffic scenarios. A current FAA air traffic manager set constraints on airspace capacities. Recommendations for future experiments included researching other credit allocation schemes and evaluating alternate constraint resolution methods. The credit assignment software was developed for the U.S. trial at NASA and was integrated into the Federal Aviation Administration's (FAA's) System-wide Enhancements for Versatile Electronic Negotiation (SEVEN) framework. The FAA has planned for SEVEN to become operational in the fall 2011 under the Collaborative Trajectory Options Program.

The FAA has on-going trials with multiple airports and airlines. The FAA is conducting studies at various airports which have different environments.

In 2009, Memphis International Airport in Tennessee began using [CDQM](#) with the FedEx operations. The demonstrations are continuing at Memphis where Delta Air Lines has begun using the CDQM program, as well as FedEx. At Memphis, FedEx conducts a massive hub operation overnight, when it is the only carrier operating there. During the day, Delta is the hub airline, with two high-density departure pushes. Delta and its regional affiliates account for nearly 85 percent of passenger-carrier departures at Memphis. Memphis is a test system to reduce departure queues in periods of high demand that involve essentially a single airline. Delta's and FedEx's ramp towers handle their own flights. The Memphis tower handles access for the other airlines at the airport. JAPAN – Difference between CDQM and Collaborative Departure Scheduling not clear.

In 2010, New York John F. Kennedy International Airport (JFK) underwent a four-month runway resurfacing and widening project in one of the United States' busiest airspaces. The longest runway was expanded to accommodate new, larger aircraft. The construction project also included taxiway improvements and construction of holding pads. In order to minimize disruption during construction, JFK decided to use a collaborative effort using departure queue metering. With [CDQM](#), departing aircraft from JFK's many airlines was allocated a precise departure slot and waited for it at the gate rather than congesting taxiways. The procedures used during the construction project worked so well that they were extended after the runway work was completed.

The FAA plans to expand CDQM to Orlando, Florida International Airport. In 2010 the FAA conducted field evaluations. None of the 39 airlines using Orlando airport conduct hub operations there. Orlando must therefore combine the departures of eight of their biggest airlines serving the airport to account for the same percentage of departures as Delta Air Lines in Memphis. At Orlando, the main focus of CDQM has been on automated identification of departure queue management issues involving traffic management initiatives – including flights with new estimated departure control times, flights affected by departure miles-in-trail restrictions and flights needing or already assigned approval requests – as well as extended departure delays related to weather and other disruptions, and surface data integrity.

At JFK and Memphis, sharing surface surveillance data with airlines has reduced taxi times by more than one minute per departure on average. Surface metering techniques demonstrated at these facilities appear to shift an additional minute from the taxiways to the gates, conserving additional fuel. These results suggest that the combined annual savings from increased data sharing and metering could be about 7,000 hours of taxi time at JFK and 5,000 hours at Memphis.

Boston Logan International Airport hosted a demonstration to study the maximum number of aircraft authorized to push back and enter an airport's active movement area during a set time period. The goal was to conduct continuous runway operations without any stop and go movements. In August through September, preliminary findings indicated the following savings: 18 hours of taxi-time, 5100 gallons of fuel and 50 tons in carbon dioxide.

## 8. Reference Documents

### 8.1 Standards

- ICAO CDM Manual (being finalised)
- European Union, OJEU [2010/C 168/04](#): Community Specification ETSI EN 303 212 v.1.1.1: European Standard (Telecommunications series) Airport Collaborative Decision Making (A-CDM)
- EUROCAE ED-141: Minimum Technical Specifications for Airport Collaborative Decision Making (Airport-CDM) Systems
- EUROCAE ED-145: Airport-CDM Interface Specification
- ICAO CDM Manual (being finalised)
- European Union, OJEU [2010/C 168/04](#): Community Specification ETSI EN 303 212 v.1.1.1: European Standard (Telecommunications series) Airport Collaborative Decision Making (A-CDM)
- EUROCAE ED-141: Minimum Technical Specifications for Airport Collaborative Decision Making (Airport-CDM) Systems
- EUROCAE ED-145: Airport-CDM Interface Specification.

### 8.2 Procedures

#### 4.3 Guidance Material

- EUROCONTROL [A-CDM](#) Programme documentation, including an Airport-CDM Implementation Manual;
- FAA NextGen Implementation Plan 2011.

### 8.4 Approval Documents

Updates are required to the following:

- ICAO Doc 4444, *Procedures for Air Navigation Services — Air Traffic Management*;
- ICAO CDM Manual;
- Eurocontrol, A-CDM Implementation Manual;
- FAA NextGen Implementation Plan.

## Module N° B1-80: Optimized Airport Operations through A-CDM Total Airport Management

<b>Summary</b>	To enhance the planning and management of airport operations and allows their full integration in the air traffic management using performance targets compliant with those of the surrounding airspace. This entails implementing collaborative Airport Operations Planning (AOP) and where needed an Airport Operations Centre (APOC)	
<b>Main Performance Impact</b>	KPA-03 Cost-Effectiveness; KPA-04 Efficiency; KPA-05 Environment; KPA-09 Predictability	
<b>Operating Environment/Flight Phases</b>	Surface in, turn around, surface out	
<b>Applicability Considerations</b>	AOP: for use at all the airports (sophistication will depend on the complexity of the operations and their impact on the network). APOC: will be implemented at major/complex airports (sophistication will depend on the complexity of the operations and their impact on the network). Not applicable to aircraft.	
<b>Global Concept Component(s)</b>	AO – Airport Operations IM – Information Management	
<b>Global Plan Initiatives (GPI)</b>	GPI-13 Aerodrome design and management	
<b>Pre-Requisites</b>	B0-80, B0-35	
<b>Global Readiness Checklist</b>		<b>Status</b> (ready now or estimated date)
	Standards Readiness	<b>Est. 2018</b>
	Avionics Availability	NA
	Ground System Availability	<b>Est. 2018</b>
	Procedures Available	<b>Est. 2018</b>
	Operations Approvals	<b>Est. 2018</b>

### 1. Narrative

#### 1.1 General

Major airports are complex organizations involving multiple stakeholders / partners. Each has its own operations principles and sub-process and mostly operates in independent and non-collaborative manner. Optimization based on those individual processes very often lead to a sub optimal and inefficient total airport performance.

Uncoordinated operations at an airport often translate into additional delays, holding times on the surface and in the air and greater cost of operations and impact on the environment. This not only affects the airport efficiency and overall performance but also impacts the efficiency of the entire ATM network.

The lack of timely access to information regarding flight operations (e.g. arrival, departure turnaround and surface movement sequencing) increases gate to gate times and decreases the utilization efficiency of airport resources such as aircraft stands, ground equipment and services. For example delays in managing demand increase delays and holding times (airborne and ground) resulting in greater fuel burn with a negative environmental impact.

Today, information on airport operations such as the resources availability plan (e.g. runway, taxiway, gate), and aircraft readiness is not fully taken into account into the flow planning of the overall ATM System.

The improvement of the planning and management of airport operations and their full and seamless integration in the overall ATM system through exchange of information between stakeholders are crucial to achieve the performance targets set in the most congested and complex regions of the world.

**1.1.1 Baseline**

The baseline for this module is Airport CDM as described in module N°B0-80 and Air Traffic Flow and Capacity Management as described in module N° B0-35.

**1.1.2 Change brought by the module**

This module provides enhancement to the planning and management of airport operations and allows their full integration in the air traffic management through the implementation of the following:

- A collaborative Airport Operations Plan (AOP) which encompasses ‘local’ airport information and ‘shared’ information with the ATM system/ ATM network manager in order to develop a synchronized view and fully integrate the airport operations into the overall ATM network.
- An Airport Performance framework and steering with specific performance indicators and targets fully integrated into the AOP and aligned with the regional / national performance frameworks.
- A decision making support enabling airport stakeholders to communicate and co-ordinate, to develop and maintain dynamically joint plans and to execute those in their respective area of responsibility.
- Information aggregation of resources availability plans and aircraft operations planning into a consistent and pertinent reference for the different operational units on the airport and elsewhere in ATM.
- A real-time monitoring capability, as a trigger (e.g. alerts & warnings) to decision making processes, and a set of collaborative procedures to ensure a fully integrated management of airside airport processes, taking the impact on landside processes into account and supported by up-to-date and pertinent meteorological information.

**2. Intended Performance Operational Improvement**

**Metrics to determine the success of the module are proposed in the *Manual on Global Performance of the Air Navigation System (Doc 9883)*.**

<i>Cost-Effectiveness</i>	Through collaborative procedures, comprehensive planning and pro-active action to foreseeable problems a major reduction in on-ground and in-air holding is expected thereby reducing fuel consumption. The planning and pro-active actions will also support efficient use of resources, however some minor increase in resources may be expected to support the solution/s.
<i>Efficiency</i>	Through collaborative procedures, comprehensive planning and pro-active action to foreseeable problems a major reduction in on-ground and in-air holding is expected thereby reducing fuel consumption. The planning and pro-active actions will also support efficient use of resources, however some minor increase in resources may be expected to support the solution/s.
<i>Environment</i>	Through collaborative procedures, comprehensive planning and pro-active action to foreseeable problems a major reduction in on-ground and in-air holding is expected thereby reducing Noise and Air pollution in the vicinity of the airport.
<i>Predictability</i>	Through the operational management of performance, reliability and accuracy of the schedule and demand forecast will increase (in association with initiatives being developed in other modules).

<a href="#">CBA</a>	TBD
---------------------	-----



### **3. Necessary Procedures (Air & Ground)**

Procedures to instantiate and update the AOP, to collaboratively manage the airport operations and to allow communication between all the airport stakeholders and the ATM System are needed.

### **4. Necessary System Capability**

#### **4.1 Avionics**

#### **4.2 Ground Systems**

The following supporting systems functions need to be developed and implemented: a data repository to host the AOP, a display and human-machine interfaces to provide an access to the AOP and warn the appropriate airport stakeholders when a decision is required, some airport Monitoring tools and decision support tools.

A communication network across the major airport stakeholders (e.g. [AOC](#), APOC) and the Network Management Systems need to be deployed.

### **5. Human Performance**

#### **5.1 Human Factors Considerations**

**5.1.1** The identification of Human Factors considerations is an important enabler in identifying processes and procedures for this module. In particular, the human-machine interface for the automation aspects of this performance improvement will need to be considered and where necessary accompanied by mitigation risk mitigation strategies such as training, education and redundancy.

#### **5.2 Training and Qualification Requirements**

5.2.1 Training in the operational standards and procedures will be identified along with the standards and recommended practices necessary for this module to be implemented. Likewise the qualifications requirements will be identified and included in the regulatory readiness aspects of this module when they become available.

### **6. Regulatory/standardization needs and Approval Plan (Air & Ground)**

- Regulatory/Standardization: To Be Determined
- Approval Plans: To Be Determined.

### **7. Implementation and Demonstration Activities**

#### **7.1 Current Use**

- None at this time

#### **7.2 Planned or Ongoing Trials**

- **Europe:** For SESAR validation carried out by 2015.
- **USA:** For NextGen validation carried out by 2015

### **8. Reference Documents**

#### **8.1 Standards**

#### **8.2 Procedures**

#### **8.3 Guidance Material**

#### **8.4 Approval Documents**



This Page Intentionally Left Blank

## **Performance Improvement Area 1: Greener Airports**

***Thread: Remote Aerodrome Control Towers***

This Page Intentionally Left Blank

## Module N° B1-81: Remotely Operated Aerodrome Control

<b>Summary</b>	To provide a safe and cost effective ATS from a remote facility, to one or more aerodromes where dedicated, local ATS is no longer sustainable or cost effective, but there is a local economic and social benefit from aviation. This can also be applied to contingency situations and depends on enhanced situational awareness of the aerodrome under remote control.	
<b>Main Performance Impact</b>	KPA-02 Capacity, KPA-03 Cost-effectiveness; KPA-06 Flexibility; KPA-10 Safety	
<b>Operating Environment / Flight Phases</b>	TMA, Descent, Airport Surface, Climb Out.	
<b>Applicability Considerations</b>	<p>The main target for the Single and Multiple Remote Tower Services are small rural airports, which today are struggling with low business margins. Both <a href="#">ATC</a> and AFIS aerodromes are expected to benefit.</p> <p>The main targets for the Contingency Tower solution are medium to large airports – those that are large enough to require a contingency solution, but who require an alternative to <a href="#">A-SMGCS</a> based “heads down” solutions or where maintaining a visual view is required.</p> <p>Although some cost benefits are possible with remote provision of ATS to a single aerodrome, maximum benefit is expected with the remote of ATS to multiple aerodromes.</p>	
<b>Global Concept Component(s)</b>	CM: Conflict Management AO: Airport Operations	
<b>Global Plan Initiatives (GPI)</b>	GPI-13 Aerodrome design and management GPI-15 Match IMC and VMC operating capacity GPI-9 Situational awareness	
<b>Main Dependencies</b>	None	
<b>Global Readiness Checklist</b>		<b>Status (ready or date)</b>
	Standards Readiness	Est. 2018
	Avionics Availability	Est. 2018
	Infrastructure Availability	Est. 2018
	Ground Automation Availability	Est. 2018
	Procedures Available	Est. 2018
	Operations Approvals	Est. 2018

### 1. Narrative

#### 1.1 General

Remotely Operated Aerodrome Control concerns the provision of ATS to aerodrome(s) from a facility which is not located at the aerodrome itself.

Remotely Operated Aerodrome Control can be applied for a single aerodrome (either [ATC](#) or AFIS) where the local tower can be replaced by a remote facility; for multiple aerodromes where the local towers of several aerodromes can be replaced by a single remote facility; or for larger single aerodromes that require a facility to be used in contingency situations. This is illustrated in the figure overleaf.

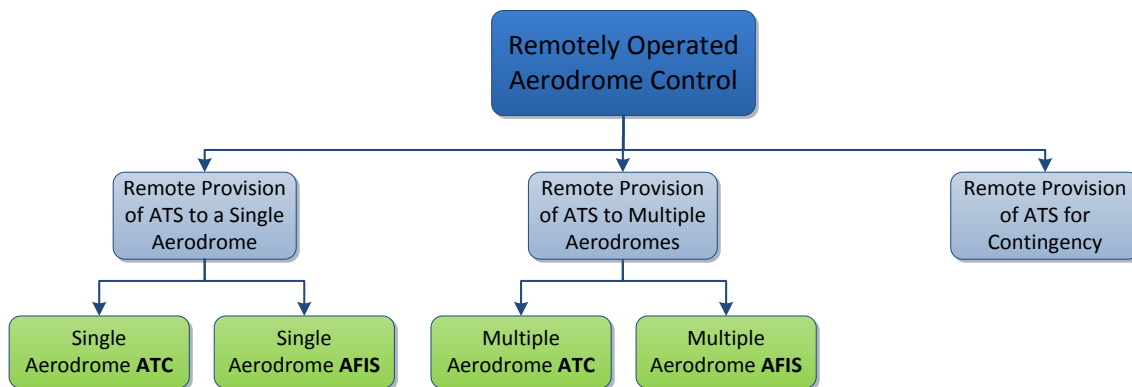

The concept does not seek to change the air traffic services provided to airspace users or change the levels of those services. Instead it changes the way those same services will be provided through the introduction of new technologies and working methods.

The visual surveillance will be provided by a reproduction of the Out of The Window (OTW) view, by using visual information capture and/or other sensors. The visual reproduction can be overlaid with information from additional sources if available, for example, surface movement radar, surveillance radar, multilateration or other positioning and surveillance implementations providing the positions of moving object within the airport movement area and vicinity. The collected data, either from a single source or combined, is reproduced for the [ATCO/AFISO](#) on data/monitor screens, projectors or similar technical solutions.

The provision of ATS from a local tower building (as in today's operations) has some constraints at some airports due to the single operational viewpoint from a central, high up perspective, and subject to prevailing viewing conditions at the time (e.g. clear, foggy). This can create some minor limitations in capability, which is accepted in 'traditional' air traffic control. With the use of reproduced visual views, these limitations can potentially be eliminated. Visual information capture and reproduction can still be done in order to replicate the operational viewpoint obtained from a traditional tower view and this may ease the transition from current operations to remote operations and also provide some common reference points. Alternatively, several operational viewpoints may be based on information captured from a range of different positions, not necessarily limited to the original tower position. This may provide an enhanced situational awareness and/or a progressive operational viewpoint. In all cases, the visual reproduction shall enable visual surveillance of the airport surface and surrounding area.

With the digitization, or computer generation of the relayed information, visual enhancements are possible. These can be used to enhance situational awareness in all visibilities.

With the removal or decommissioning of individual local towers, disparate systems and procedures can be standardized to a greater level in a shared uniform facility.

With many aerodromes operating from a shared facility using common systems, the possibility to share system wide information can increase.

The ATCO/AFISO will not have the ability to perform any tasks that are external to the control facility e.g. physical runway inspection. The aim is that that they primarily will focus on the pure ATS tasks, and other tasks will be secondary and/or performed by personnel local to the aerodrome.

Although it is not necessary, it will be possible to remove the local control tower as it will no longer be used for the provision of air traffic services. The need to have a single, tall tower building at the aerodrome will disappear. The infrastructure (service, maintenance etc.) that goes along with maintaining such a building will also become redundant. Instead, a local installation consisting of systems/sensors will be maintained (perhaps less frequently) by central maintenance teams. The remote facility will also require maintenance, but it is expected that a more 'traditional' building using common systems and components will lead to a reduction in overall maintenance costs.

### 1.1.1 Baseline

Remotely Operated Aerodrome Control will be built on today's local aerodrome operations and services.

### 1.1.2 Change brought by the module

The Single Tower services will be implemented first (2012 onwards), thereby acting as a baseline for the Multiple Tower services. Contingency services are already in initial service and will evolve with the capabilities developed for Remotely Operated Aerodrome Control.

Specifically, the Out of the Window component of this solution will enhance existing contingency solutions, e.g. London Heathrow Virtual Contingency Facility.

The main improvements will be:

- Safety;
- Lower operating costs for the aerodrome;
- Lower cost of providing ATS to the airspace users;
- More efficient use of staff resources;
- Higher levels of standardization/interoperability across remote aerodrome systems and procedures;
- Higher situational awareness in low visibility conditions using visual enhancements;
- Greater capacity in low visibility conditions;
- Greater capacity in contingency situations.

### 1.2 *Element 1: Remote Provision of ATS for Single Aerodromes*

The objective of Remote Provision for a Single Aerodrome is to provide the ATS defined in ICAO Documents 4444, 9426 and EUROCONTROL's Manual for AFIS for one aerodrome from a remote location. The full range of ATS should be offered in such a way that the airspace users are not negatively impacted (and possibly benefit) compared to local provision of ATS. The overall ATS will remain broadly classified into either of the two main service subsets of TWR or AFIS.

The main change is that the [ATCO](#) or [AFISO](#) will no longer be located at the aerodrome. They will be re-located to Remote Tower facility or a Remote Tower Centre (RTC).

It is likely that an RTC will contain several remote tower modules, similar to sector positions in an ACC/ATCC. Each tower module will be remotely connected to (at least) one airport and consist of one or several Controller Working Positions (CWP), dependent on the size of the connected airport. The ATCO will be able to perform all ATS tasks from this CWP.

### 1.3 *Element 2: Remote Provision of ATS for Multiple Aerodromes*

The objective of Remote Provision for Multiple Aerodromes is to provide aerodrome ATS for more than one aerodrome, by a single ATCO/AFISO, from a remote location i.e. not from individual control towers local to the individual aerodromes. As with Single Aerodromes, the full range of ATS should be offered in such a way that the airspace users are not negatively impacted (and possibly benefit) compared to local provision of ATS and the overall ATS will remain broadly classified into either of the two main service subsets of TWR or AFIS.

The Remote Provision of ATS to Multiple Aerodromes can be operated in a number of ways depending on several factors. The common, general principle is that a single ATCO/AFISO will provide ATS for a number of aerodromes. A number of staff resources (ATS personnel) and a number of CWP will be co-located in an RTC which may be a separate facility located far from any airport, or an additional facility co-located with a local facility at an aerodrome.

The additional factors to be considered for remote ATS to multiple Aerodromes include:

- Resource Management – balancing of shift size according to the number of aerodromes, traffic demand, and the number of aerodromes a single ATCO/AFISO can provide service to;
- Controller Working Positions – the number and configuration of [CWP](#) in the RTC. A single CWP may serve one aerodrome, several aerodromes, or share service provision to the same aerodrome with other CWP (larger aerodromes only);
- Operating Methods – it is expected that the [ATCO/AFISO](#) will be able to provide ATS to more aerodromes when there are no current aircraft movements at those aerodromes yet the airspace is established and provision of ATS is required. As traffic increases, the maximum number of aerodromes per single ATCO/AFISO will decrease;
- Air Traffic Management – The ability to accommodate both [IFR](#) and VFR traffic requires management – demand and capacity balance. Slot coordination and traffic synchronization across multiple aerodromes will help extract maximum benefit from Multiple Tower by reducing the occasions when several aerodromes have simultaneous aircraft movements;
- Aerodrome clustering – the selection of which aerodromes can be operated in parallel by a single ATCO/AFISO;
- Approach Control – whether the approach control is also provided by the multiple aerodrome ATCO/AFISO, whether it is provided by a dedicated APP controller, or a combination of both;
- Each factor contains several options and it is the combination of these options for a given set of aerodromes that determines the make-up of an RTC.

#### **1.4 Element 3: Remote Provision of ATS for Contingency Situations**

The objective of this service is to apply the principles used for Remote ATS in order to establish standby installations and a contingency solution for medium to high density airports, to assist in cases where the primary (local) tower is out of service and contingency is required.

A Remotely Operated Aerodrome Control facility can be used to provide alternative facilities, and the Remote Tower can provide alternative services, without compromising safety and at a reasonable cost, in cases where:

- Visual operations are required;
- Radar coverage is not available;
- Systems such as A-SMGCS are not available.

This service provides a cost effective alternative to the systems used at many large airports (e.g. A-SMGCS based). This may enable also the small and medium size airports (i.e. those without 'traditional' contingency solutions) to fulfil or improve upon their obligations with respect to European SES regulation CR §8.2 "An [ANSP](#) shall have in place contingency plans for all services it provides in cases of events which result in the significant degradation or interruption of its services".

## 2. Intended Performance Operational Improvement

Metrics to determine the success of the module are proposed in the *Manual on Global Performance of the Air Navigation System (Doc 9883)*.

<i>Capacity</i>	Capacity may be increased through the use of digital enhancements in low visibility
<i>Efficiency</i>	Efficiency benefits are provided in three main areas. The first is the cost effectiveness benefits described above, centred around using assets and resources more efficiently thus leading to a more cost effective service. The second is the ability to exploit the use of technology in the provision of the services. Digital enhancements can be used to maintain throughput in low visibility conditions, thus making a more efficient use of available capacity
<i>Cost Effectiveness</i>	The benefit is expected through provision of air traffic services from remote facilities. For single aerodromes these facilities will be cheaper to maintain, able to operate for longer periods and enable lower staffing costs (through centralised training and resource pools). For multiple aerodrome additional cost effectiveness benefits can be achieved through the ability to control a greater number of aerodromes with fewer individual facilities and controllers.
<i>Flexibility</i>	Flexibility may be increased through a greater possibility to extend opening hours when through remote operations
<i>Safety</i>	The provision of air traffic services (facilities and staff) from a remote location should provide the same, or greater if possible, levels of safety as if the services were provided locally. The use of the digital visual technologies used in the RVT may provide some safety enhancements in low visibility.

<a href="#">CBA</a>	<p>Cost Benefit Assessments for previous remote tower research programs have shown a cost benefit to exist in the target environment. Since there are no current operational remote towers these CBA were necessarily based on some assumptions. However, these assumptions were developed by a working group of subject matter experts and considered reasonable working assumptions.</p> <p>There are costs associated with remote tower implementation including the costs of procurement and installation of equipment. There are additional capital costs in terms of new hardware and adaptation of buildings. New operating costs are incurred in the form of facilities leases, repairs and maintenance and communication links. There are then short term transition costs such as staff re-training, re-deployment and relocation costs.</p> <p>Against this, savings are derived from remote tower implementation. A significant portion of these result from savings in employment costs due to reduction in shift size. Previous CBA indicated a reduction in staff costs of 10% to 35% depending on the scenario. Other savings arise from reduced capital costs, particularly savings from not having to replace and maintain tower facilities and equipment and from a reduction in tower operating costs.</p> <p>The CBA concluded that remote tower does produce positive financial benefits for <a href="#">ANSP</a>. Further Assessment of Costs and Benefits (ACB) will be conducted during 2012 and 2013 using a range of implementation scenarios (Single, Multiple, Contingency).</p>
---------------------	---



### 3. Necessary Procedures (Air & Ground)

The concept aims to maintain as many current air and ground procedures as possible. The Air Traffic Services provided remain the same and there should be no impact on airspace users.

Some new operating methods may be required for tasks which are external to the current aerodrome tower. The [ATCO/AFISO](#) will not have the ability to perform any tasks that are external to the control facility e.g. physical runway inspection. The aim is that they primarily will focus on the pure ATS tasks, and other tasks will be secondary and/or performed by personnel local to the aerodrome.

New fallback procedures are required in case of full or partial failure of the RTC. In cases of complete failure, there is no possibility for reduced operations. All ATS will be suspended until the system can be at least partially restored and traffic may be re-routed to other aerodromes in the meantime.

In cases of partial failure, it is expected that the failure scenario can be mapped to existing procedures. For example, loss of visual reproduction when operating remotely can be likened to low visibility when operating from a local tower. Therefore 'local' [LVP](#) could be adapted for use under visual reproduction failure. However, this will only apply when contingency procedures do not require a local solution.

### 4. Necessary System Capability

#### 4.1 Avionics

NIL

#### 4.2 Ground Systems

For Remotely Operated Aerodrome Control the main technology is the development of camera-based solutions. Camera and display technologies are focused at creating a uniform visual view which is perceived as smooth and delivers the level of quality and information required to provide safe and efficient ATS. Other CWP and [HMI](#) technologies are focused on creating an acceptable method for interaction with the remote tower systems and controller working position as a whole.

Situational awareness is addressed by looking at placement of visual surveillance sensors, to enhance the visual view by means of night vision and image enhancement, and extend it with graphical overlay such as tracking information, weather data, visual range values and ground light status etc.

Except for the implementation of sensors and facilities on the airport, suitable communication capabilities between the airports and the RTC are required.

### 5. Human Performance

#### 5.1 Human Factors Considerations

**5.1.1** The identification of Human Factors considerations is an important enabler in identifying processes and procedures for this module. In particular, the human-machine interface for the automation aspects of this performance improvement will need to be considered and where necessary accompanied by mitigation risk mitigation strategies such as training, education and redundancy.

#### 5.2 Training and Qualification Requirements

**5.2.1** Training in the operational standards and procedures will be identified along with the standards and recommended practices necessary for this module to be implemented. Likewise the qualifications requirements will be identified and included in the regulatory readiness aspects of this module when they become available.

### 6. Regulatory/standardization needs and Approval Plan (Air & Ground)

- Regulatory/Standardization: To Be Determined
- Approval Plans: To Be Determined.

Discussion: Material for provision of ATS in Contingency situations already exists, but not for the solutions delivered by this concept. However, no regulatory or standardisation material exists for the remote provision of ATS. It will therefore need assessment, development and approval as appropriate before operations.

## 7. Implementation and Demonstration Activities

### 7.1 Current Use

There is no current operational use of Remotely Operated Aerodrome Control in normal operations. Some aerodromes have contingency facilities, but none that include an OTW view.

**Europe** - An implementation project in Sweden began in 2011 for Sundsvall and Örnsköldsvik aerodromes. The system, jointly developed by Saab and LFV, is expected to be installed and tested in 2012 and to become operational in 2012/2013. Air traffic at Sundsvall and Örnsköldsvik airports will then be controlled from a joint air traffic control centre located in Sundsvall.

### 7.2 Planned or Ongoing Trials

In support of ongoing implementations and further developments, several trials are planned during the 2011 to 2014 period. A range of candidate operational environments in Sweden (ATC) Norway (AFIS) and Australia will be selected. Trial and environment specific methods and procedures will be developed. The set of trials is shown in the figure below.

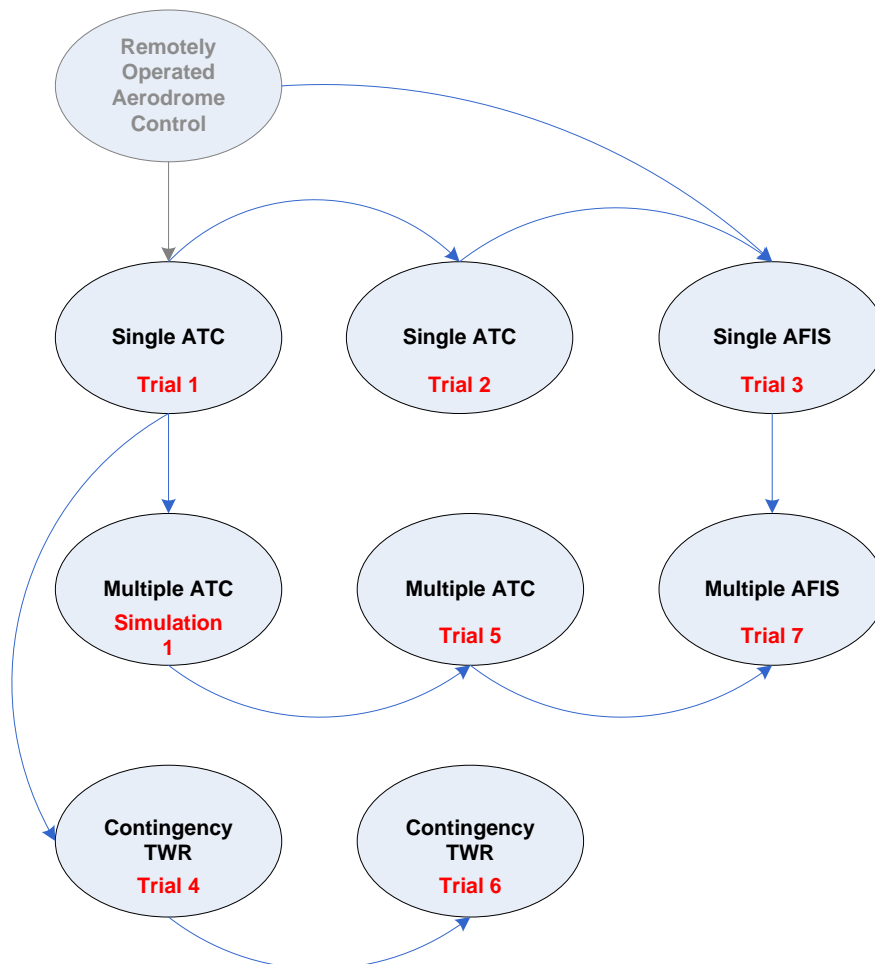

Shadow Mode trials for the Single Tower service will take place in 2011 and 2012.

A Real Time Simulation for the Multiple Tower service will be conducted in 2012, followed by Shadow Mode trials in 2013 and 2014. Shadow Mode trials for the Contingency Service will take place in 2013 and 2014.

**United States** – Completed trial for Staffed NextGen Towers (SNT) which conducted Shadow Mode for Single Tower Services in 2011.

**SESAR:** - 2011 a live trial was conducted for providing ATS to Ängelholm airport from the Malmö ATCC R&D Remote Tower Centre, testing the feasibility of conducting remotely nominal and non-nominal operations, as well as the technical feasibility of capturing the "out of window" traffic situation and operational environment from a single airport and displaying this picture in the remote site.

Trials on remote provision of ATS to an airdrome during contingency situations in the 2012 – 2014 timeframe.

Trials on remote provision of ATS to multiple aerodromes in parallel from one single remote control facility in the 2012 – 2014 timeframe.

## **8. Reference Documents**

### **8.1 Standards**

### **8.2 Procedures**

### **8.3 Guidance Material**

### **8.4 Approval Documents**

This Page Intentionally Left Blank

**Performance Improvement Area 2: Globally Interoperable  
Systems and Data - Through Globally Interoperable System  
Wide Information Management**

*Thread: FF/ICE*

## Module N° B0-25: Increased Interoperability, Efficiency and Capacity through Ground-Ground Integration

<b>Summary</b>	To improve coordination between Air Traffic Service Units (ATSUs) by using ATS Inter-facility Data Communication (AIDC) defined by ICAO Doc 9694. The transfer of communication in a data link environment improves the efficiency of this process particularly for Oceanic ATSUs..	
<b>Main Performance Impact</b>	KPA-02 Capacity, KPA-04 Efficiency, KPA-07 Global Interoperability, KPA-10 Safety	
<b>Operating Environment/Phases of Flight</b>	All flight phases and all type of ATS units	
<b>Applicability Considerations</b>	Applicable to at least 2 ACCs dealing with en-route and/or TMA airspace. A greater number of consecutive participating ACCs will increase the benefits.	
<b>Global Concept Component(s)</b>	CM - Conflict management IM - Information Management	
<b>Global Plan Initiatives (GPI)</b>	GPI-16 Decision Support Systems	
<b>Pre-Requisites</b>	Linkage with B0-40	
<b>Global Readiness Checklist</b>		<b>Status (ready now or estimated date)</b>
	Standards Readiness	√
	Avionics Availability	No requirement
	Ground systems Availability	√
	Procedures Available	√
	Operations Approvals	√

### 1. Narrative

#### 1.1 General

Flights which are being provided with an [ATC](#) service are transferred from one ATC unit to the next in a manner designed to ensure full safety. In order to accomplish this objective, it is a standard procedure that the passage of each flight across the boundary of the areas of responsibility of the two units is co-ordinated between them beforehand and that the control of the flight is transferred when it is at, or adjacent to, the said boundary.

Where it is carried out by telephone, the passing of data on individual flights as part of the co-ordination process is a major support task at ATC units, particularly at Area Control Centres (ACCs). The operational use of connections between Flight Data Processing Systems (FDPs) at ACCs replacing phone coordination (On-Line Data Interchange (OLDI)) is already proven in Europe.

This is now fully integrated into the "ATS Inter-facility Data Communications" (AIDC) messages in the PANS-ATM, which describes the types of messages and their contents to be used for operational communications between ATS unit computer systems. This type of data transfer (AIDC) will be the basis for migration of data communications to the aeronautical telecommunication network (ATN).

The AIDC module is aimed at improving the flow of traffic by allowing neighbouring air traffic control units to exchange flight data automatically in the form of coordination and transfer messages.

With the greater accuracy of messages based on the updated trajectory information contained in the system and where possible updated by surveillance data, controllers have more reliable information on the

conditions at which aircraft will enter in their airspace of jurisdiction with a reduction of the workload associated to flight coordination and transfer. The increased accuracy and data integrity permits the safe application of reduced separations.

Combined with data link applications it also allows the coordination and transfer of control.

These improvements translate directly into a combination of performance improvements.

Information exchanges between flight data processing systems are established between air traffic control units for the purposes of notification, coordination and transfer of flights and for the purposes of civil-military coordination. This information exchanges rely upon appropriate and harmonized communication protocols to secure their interoperability. They apply to:

(a) communication systems supporting the coordination procedures between air traffic control units using a peer-to-peer communication mechanism and providing services to general air traffic;

(b) communication systems supporting the coordination procedures between air traffic services units and controlling military units, using a peer-to-peer communication mechanism.

### 1.1.1 Baseline

The baseline for this module is the classical coordination by phone, and procedural and/or radar distance separations.

### 1.1.2 Change brought by the module

The module makes available a set of messages to describe consistent transfer conditions via electronic means across centre boundaries. It consists of the implementation of the set of [AIDC](#) messages in the Flight Data Processing Systems (FDPS) of the different ATS units involved and the establishment of a Letter of Agreement (LoA) between these units to set the appropriate parameters.

Prerequisites for the module, generally available before its implementation are an ATC system with a flight data processing functionality and a surveillance data processing system connected to each other.

### 1.1.3 Other remarks

This module is a first step towards the more sophisticated 4D trajectory exchanges between both ground/ground and air/ground according to the ICAO Global ATM Operational Concept.

## 2. Intended Performance Operational Improvement

**Metrics to determine the success of the module are proposed in the *Manual on Global Performance of the Air Navigation System (Doc 9883)*.**

<i>Capacity</i>	Reduced controller workload and increased data integrity supporting reduced separations translating directly to cross sector or boundary capacity flow increases.
<i>Efficiency</i>	The reduced separation can also be used to offer more frequently to aircraft flight levels closer to the flight optimum; in certain cases, this also translates in reduced en-route holding.
<i>Global Interoperability</i>	Seamlessness: the use of standardized interfaces reduces the cost of development, allows controller to apply the same procedures at the boundaries of all participating centres and border crossing becomes more transparent to flights.
<i>Safety</i>	Better knowledge of more accurate flight plan information

<a href="#">CBA</a>	Increase of throughput at <a href="#">ATC</a> unit boundary, reduced ATCo Workload will exceed FDPS software changes cost. The business case is dependent on the environment
---------------------	--

## 3. Necessary Procedures (Air & Ground)

Required procedures exist. They need local instantiation on the specific flows and should be spelled out in Letter of Agreement between ATC Units; the experience from other regions can be a useful reference.

## 4. Necessary System Capability

### 4.1 Avionics

No specific airborne requirements

### 4.2 Ground Systems

Technology is available. It consists in implementing the relevant set of [AIDC](#) messages in Flight Data Processing and could use the ground network standard [AFTN-AMHS](#) or [ATN](#). Europe is presently implementing it over [IP](#) Wide Area Networks.

It also includes for oceanic ATSUs a function supporting transfer of communication via data link.

## 5. Human Performance

### 5.1 Human Factors Considerations

**5.1.1** Ground interoperability reduces voice exchange between ATCOs and decreases workload. System supporting appropriate [HMI](#) for ATCOs is required.

Human Factors have been taken into consideration during the development of the processes and procedures associated with this module. Where automation is to be used, the Human-Machine interface has been considered from both a functional and ergonomic perspective (See Section 6 for examples). The possibility of latent failures however, continues to exist and vigilance is requested during all implementation actions. It is further requested that human factor issues, identified during implementation, are reported to the international community through ICAO as part of any safety reporting initiative.

### 5.2 Training and Qualification Requirements

**5.2.1** Training for making the most of the automation support will be required. Training in the operational standards and procedures are required for this module and can be found in the links to the documents in Section 8 to this module. Likewise, the qualifications requirements are identified in the regulatory requirements in Section 6 which form an integral part to the implementation of this module.

## 6. Regulatory/standardization needs and Approval Plan (Air & Ground)

- Regulatory/Standardization: Use current published criteria that include:
  - ICAO Doc 4444, *Procedures for Air Navigation Services — Air Traffic Management*;
  - EU Regulation, EC No 552/2004.
- Approval Plans: To Be Determined, based upon regional consideration of AIDC.

## 7. Implementation and Demonstration Activities

Although already implemented in several areas, but there is a need to complete the existing standards to avoid system specific and bilateral protocol. For oceanic data link application, [NAT](#) and APIRG (cf ISPCG PT/8- WP.02 - GOLD) have defined some common coordination procedures and messages between oceanic centers for data link application (ADS-C CPDLC).



## 7.1 Current Use

- **Europe** - it is mandatory for exchange between ATS units.

[http://europa.eu/legislation\\_summaries/transport/air\\_transport/l24070\\_en.htm](http://europa.eu/legislation_summaries/transport/air_transport/l24070_en.htm)

European Commission has already issued a mandate for this level of [IOP](#) (Law 552/2004, 10/04/2004; Implementing Rule 1032/2006, on the interoperability of the European Air Traffic Management network, "COTR"; Community Specification OLDI 4.1) based on the so-called OLDI standard. [OLDI](#) is considered as the European Implementation of ICAO's AIDC.

EUROCONTROL Specification of Interoperability and Performance Requirements for the Flight Message Transfer Protocol (FMTP). The available set of messages to describe and negotiate consistent transfer conditions via electronic means across centres' boundaries have been used for trials in Europe in 2010 in the scope of EUROCONTROL's FASTI initiative.

- **India** - AIDC implementation is in progress in Indian airspace for improved coordination between ground ATC centres. Major Indian airports/ATC centres have integrated ATS automation systems having AIDC capability. AIDC functionality is operational between Mumbai and Chennai ACCs. AIDC will be implemented within India by 2012. AIDC trials are underway between Mumbai and Karachi (Pakistan) and are planned between India and Muscat in coordination with Oman.

AIDC is in use In Asia-Pacific region Australia, New-Zealand, Indonesia and others

## 7.2 Planned or Ongoing Activities

## 8. Currently in operation. Reference Documents

### 8.1 Standards

- ICAO Doc 4444, *Procedures for Air Navigation Services - Air Traffic Management*, Appendix 6 - ATS Interfacility Data Communications (AIDC) Messages
- ICAO Doc 9880, *Manual on Detailed Technical Specifications for the Aeronautical Telecommunication Network (ATN) using ISO/OSI Standards and Protocols*, Part II — Ground-Ground Applications — Air Traffic Services Message Handling Services (ATSMHS).

### 8.2 Procedures

To be determined.

### 8.3 Guidance Material

- ICAO Doc 9694, *Manual of Air Traffic Services Data Link Applications*; part 6
- GOLD Global Operational Data Link Document ([APANPIRG](#), NAT SPG), June 2010;
- Pan Regional Interface Control Document for Oceanic ATS Interfacility Data Communications (PAN ICD) Coordination Draft Version 0.3. 31 August 2010;
- Asia/Pacific Regional Interface Control Document (ICD) For ATS Interfacility Data Communications (AIDC). ICAO Asia/Pacific Regional Office. [http://www.bangkok.icao.int/edocs/icd\\_aidc\\_ver3.pdf](http://www.bangkok.icao.int/edocs/icd_aidc_ver3.pdf)
- EUROCONTROL Standard for On-Line Data Interchange (OLDI); and EUROCONTROL Standard for ATS Data Exchange Presentation (ADEXP)

This Page Intentionally Left Blank

## Module N° B1-25: Increased Interoperability, Efficiency and Capacity through [FF-ICE/1](#) application before Departure

<b>Summary</b>	To introduce FF-ICE step 1, providing ground-ground exchanges using common flight information reference model (FIXM) and XML standard formats before departure.	
<b>Main Performance Impact</b>	KPA-02 Capacity, KPA-04 Efficiency KPA-06 Flexibility, KPA-07 Global Interoperability, KPA-08 Participation by the ATM Community; KPA-10 Safety,	
<b>Operating Environment / Flight Phases</b>	Planning phase for FF-ICE/1	
<b>Applicability Considerations</b>	Applicable between <a href="#">ATC</a> units and to facilitate exchange between <a href="#">ASP</a> , Airspace user operations and airport operations.	
<b>Global Concept Component(s)</b>	DCB – Demand capacity Balancing CM - Conflict management IM - Information Management	
<b>Global Plan Initiatives (GPI)</b>	GPI-6 <a href="#">ATFM</a> GPI-7 Dynamic and flexible route management GPI-16 Decision Support Systems	
<b>Main Dependencies</b>	Successor of B0-25 and B0-30 ( <a href="#">AIXM</a> ) Connection to B1-30 (AIRM) and B1-31 (SWIM)	
<b>Global Readiness Checklist</b>		<b>Status (ready or estimated date)</b>
	Standards Readiness	Est 2016
	Avionics Availability	No requirement
	Ground systems Availability	Est 2018
	Procedures Available	Est 2018
	Operations Approvals	Est 2018

### 1. Narrative

#### 1.1 General

The use of [FF-ICE/1](#) permits a better sharing of Flight information before departure for improved Flight planning submission and amendment, and for pre-flight ATFM by facilitating the flight information sharing between all stakeholders (Airspace users, Airport and ASP).

##### 1.1.1 Baseline

The baseline for this module is present process for submission of [FPL](#) through ICAO standardized FPL/2012 messages (Amendment 1 to PANS/ATM) and automated standard for information exchange through a set of messages and limited need for direct speech coordination (B0-25).

##### 1.1.2 Change brought by the module

This module implements FF-ICE/1 before departure.

ICAO SARPs for FF-ICE/1 will be developed by ICAO groups between 2012 and 2015. It will facilitate the exchange of information associated to Flight plan, allowing more flexibility for flight data submission, amendment and publishing.

The objective of FF-ICE/1 is to establish the basis for transition towards a full FF-ICE deployment. This basis consists of:

- Introduction of a Globally Unique Flight Identifier: [GUF](#)
- Introduction of common data format, i.e. Flight Information eXchange Model (FIXM) in the context of the overall transition to XML for aeronautical information.
- Introduction of basic roles, rules and procedures for submission and maintenance of FF-ICE information including provisions for the early sharing of trajectory information.

The use of the new format will facilitate the evolution of the contents of [FPL](#) to introduce new data and solve specific regional needs.

The changes included in FF-ICE/1 are the following:

- Support for early provision of flight intention information.
- Support for exchange of 4D Trajectory information between the AOC and the [ASP](#)
- New format for flight and flow information using internet protocol and XML
- Globally Unique Flight Identifier (GUF)
- FF-ICE/1 Information Elements (first list of Information elements).

The foreseen Services related to Flight Information Submission and Management in the frame of FF-ICE/1 are:

- Initial submission
- Validation
- GUF Allocation (after the initial submission)
- Nominal trajectory Generation (in absence of Airspace users defined trajectory)
- Flight Information Negotiation (to solve conflict between Airspace users flight and existing constraints)
- Flight Information Update (to change or add to current flight information)
- Acknowledgement/rejection
- Flight Information Publication
- Flight Information Subscription
- Flight Information Cancellation
- Flight Suspension
- Flight Information

### 1.1.3 Other remarks

This module is a first step towards the more sophisticated 4D trajectory for both ground/ground and air/ground exchanges according to the ICAO Global ATM Operational Concept.

## 2. Intended Performance Operational Improvement

Metrics to determine the success of the module are proposed at Doc 9883.

<i>Capacity</i>	Reduced controller workload and increased data integrity supporting reduced separations translating directly to cross sector or boundary capacity flow increases.
<i>Efficiency</i>	Better knowledge of aircraft capabilities allows trajectories closer to Airspace user preferred trajectories and better planning
<i>Flexibility</i>	The use of <a href="#">FF-ICE/1</a> allows a quicker adaptation on route changes.
<i>Global Interoperability</i>	The use of new mechanism for <a href="#">FPL</a> filling and information sharing will facilitate the Flight data sharing among the actors.
<i>Participation by the ATM community</i>	<a href="#">FF-ICE/1</a> for Ground-Ground application will facilitate <a href="#">CDM</a> , the implementation or the systems interconnection for Information sharing, trajectory or slot negotiation before departure providing better use of capacity and better flight efficiency...
<i>Safety</i>	More accurate flight information

<a href="#">CBA</a>	The new services have to be balanced by the cost of software change in the <a href="#">ASP</a> , <a href="#">AOC</a> and airport ground systems
---------------------	---

### 3. Necessary Procedures (Air & Ground)

- The use of FF-ICE/1 will require significant change in the procedures of Flight information submission from the initial intention to the full set of data before departure and the sharing and use by the actors (Airports operators, Air Traffic Services, ATFM).
- FF-ICE/1 Manual, SARPS and concept of use to be developed.

### 4. Necessary System Capability

#### 4.1 Avionics

There are no specific airborne requirements, but use of Electronic Flight Bag onboard associated to high speed connection, in particular when aircraft is on the ground, could facilitate the FF-ICE information sharing with both AOC and ASP.

#### 4.2 Ground Systems

Ground ATC functionalities dealing with flight information will need to be updated to cater for FF-ICE/1.

Airspace users systems will need to be modified to support the provision of FF-ICE to ANSPs.

### 5. Human Performance

#### 5.1 Human Factors Considerations

**5.1.1** The identification of Human Factors considerations is an important enabler in identifying processes and procedures for this module. In particular, the human-machine interface for the automation aspects of this performance improvement will need to be considered and where necessary accompanied by mitigation risk mitigation strategies such as training, education and redundancy.

#### 5.2 Training and Qualification Requirements

**5.2.1** Training to the new procedures and change in flight data information is required for operators in charge of their provision and for the users of this information.

**5.2.2** Training in the operational standards and procedures will be identified along with the standards and recommended practices necessary for this module to be implemented. Likewise the qualifications requirements will be identified and included in the regulatory readiness aspects of this module when they become available.

### 6. Regulatory/standardization needs and Approval Plan (Air & Ground)

- **Regulatory/Standardization:** Use current published requirements given in Section 8.4.  
New standards and recommended procedures documentation is needed for FF-ICE at this time.
- **Approval Plans:** To Be Determined, based upon regional consideration of advanced [AIDC](#) and FF-ICE.

**Discussion:** For advanced AIDC, ICAO material is available (PANS-ATM, ATN). Regions should consider the possible mandating of AIDC. Means of compliance are also described in EUROCONTROL [OLDI](#) standard and EU regulations: i.e. Implementing Rule on Coordination and Transfer (CE 1032/2006).

For FF-ICE/1 SARPS should be developed and validated (cf [ATMRPP](#) tasks, ref WP470, 479, 480)

### 7. Implementation and Demonstration Activities

#### 7.1 Current Use

None at this time.

#### 7.2 Planned or Ongoing Trials

- **SESAR:** Flight Object validation is taking place in the frame of the SESAR projects 10.2.5 and 4.3 and is planned between 2011 and 2013.
- FF-ICE/1 could be considered as part of SESAR WP8 and WP14 in the development of [AIRM](#).

- United States – Flight Information Exchange Model with full FF-ICE functionality will be standardized will be available by 2018.

## 8. Reference Documents

Same as B0-25 +

### 8.1 Standards

- Eurocae ED-133 June 09 Flight Object Interoperability Specification;
- [FF-ICE/1](#) based on FIXM to be developed.

### 8.2 Procedures

### 8.3 Guidance Material

- FF-ICE concept document;
- EUROCONTROL Specification for On-Line Data Interchange (OLDI), V4.2.

### 8.4 Approval Documents

- ICAO Doc 4444, *Procedures for Air Navigation Services — Air Traffic Management*;
- EU Regulation, EC No 552/2004.

## Module N° B2-25 Improved Coordination through multi-centre Ground-Ground Integration: ([FF-ICE/1](#) and Flight Object, SWIM)

<b>Summary</b>	FF-ICE supporting Trajectory based Operations through exchange and distribution of information for multicentre operations using Flight Object implementation and Interoperability (IOP) standards.  Extension of use of FF-ICE after departure supporting Trajectory based Operations. New system interoperability standards will support the sharing of ATM services involving more than two ATSUs.	
<b>Main Performance Impact</b>	KPA-02 Capacity, KPA-04 Efficiency KPA-06 Flexibility, KPA-07 Global Interoperability, KPA-08 Participation by the ATM community KPA-10 Safety,	
<b>Operating Environment/Phases of Flight</b>	All flight phases and all types of ground stakeholders	
<b>Applicability Considerations</b>	Applicable to all ground stakeholders (ATS, Airports, Airspace Users) in an homogeneous areas, potentially global.	
<b>Global Concept Component(s)</b>	AUO –Airspace User Operations AO – Airport Operations DCB – Demand capacity Balancing CM - Conflict management IM - Information Management	
<b>Global Plan Initiatives (GPI)</b>	GPI-7 Dynamic and flexible route management GPI-12 Functional integration of ground systems with airborne systems GPI-16 Decision Support Systems	
<b>Pre-Requisites</b>	B1-25, B1-31	
<b>Global Readiness Checklist</b>		<b>Status (ready now or estimated date)</b>
	Standards Readiness	Est; 2018
	Avionics Availability	No requirement
	Ground Systems Availability	Est; 2020
	Procedures Available	Est. 2020
	Operations Approvals	Est; 2020

### 1. Narrative

#### 1.1 General

##### 1.1.1 Baseline

The baseline for this module is coordination transfers and negotiation as described in B0-25 and B1-25 and the first step of [FF-ICE/1](#) for ground application, during the planning phase before departure.

##### 1.1.2 Change brought by the module

Sharing of all the Flight and Flow information during Planning and Execution Flight Phase

FF-ICE/1 will be extended for a complete use of FF-ICE after departure supporting Trajectory based Operations. The technical specification for FF-ICE will be implemented in the ground systems (ASP, [AOC](#), Airport) using Flight Object implementation and IOP standard.

The module makes available a protocol to support exchange and distribution of information for multicentre operations.

The Flight Object (FO) concept has been developed to specify the information on environments, flights and flows managed by and exchanged between [FDPS](#). FF-ICE is a subset of FO but includes, at conceptual level, the interface with the Airspace User (AOC and aircraft). FO will be deployed in the target period of FF-ICE/1. FF-ICE/1 standards should therefore be consistent with the evolving standards for FO and especially complement them with standards on the ground-ground interactions with the Air Space Users.”

The first implementations of SWIM (B1-31, B2-31) will facilitate flight information sharing.

### 1.1.3 Other remarks

This module is a second step towards the more sophisticated 4D trajectory exchanges between both ground/ground and air/ground according to the ICAO Global ATM Operational Concept.

## 2. Intended Performance Operational Improvement

**Metrics to determine the success of the module are proposed in the *Manual on Global Performance of the Air Navigation System (Doc 9883)*.**

<i>Capacity</i>	Reduced controller workload and increased data integrity and improved seamlessness at borders of ATSU's
<i>Efficiency</i>	Through more direct route and use of RTA to upstream centers.
<i>Flexibility</i>	Better adaptation to user request change through facilitated information exchange
<i>Global Interoperability</i>	Easier facility of system connexion and wide exchange of the information among the actors
<i>Participation by the ATM community</i>	FF-ICE will facilitate the participation of all interested parties
<i>Safety</i>	More accurate and updated information
<i>Human performance</i>	Positive impact of more accurate information.

<a href="#">CBA</a>	Balance between cost of ground system change and improved capacity/flight efficiency to be determined.
---------------------	--

## 3. Necessary Procedures (Air & Ground)

There is a need for new procedures for new set of applications towards Trajectory Based operation.

## 4. Necessary System Capability

### 4.1 Avionics

Aircraft access to SWIM will be introduced by B2-31.

### 4.2 Ground Systems

ATM ground systems need to support [IOP](#) and SWIM concept.

Data communication infrastructure is required to support high speed ground-ground communication between ground systems and be connected to air-ground data links.



## 5. Human Performance

### 5.1 Human Factors Considerations

5.1.1 The identification of Human Factors considerations is an important enabler in identifying processes and procedures for this module. In particular, the human-machine interface for the automation aspects of this performance improvement will need to be considered and where necessary accompanied by mitigation risk mitigation strategies such as training, education and redundancy.

### 5.2 Training and Qualification Requirements

5.2.1 This module will eventually contain and number of personnel training requirements. As and when they are developed, they will be included in the documentation supporting this module and their importance signified. Likewise, any qualifications requirements that are recommended will become part of the regulatory needs prior to implementation of this performance improvement.

## 6. Regulatory/standardization needs and Approval Plan (Air & Ground)

- **Regulatory/Standardization:** Updates required to current published requirements given in Section 8.4 Of this material ED133, addresses only civil [ATSU's FDP](#) interoperability needs. Other Flight Information users needs will also be accommodated.

New standards for CDM applications and Flight Information sharing/access are needed.

- **Approval Plans:** To Be Determined.

## 7. Implementation and Demonstration Activities

### 7.1 Current Use

### 7.2 Planned or Ongoing Activities

In SESAR Project 10.2.5, Flight Object Interoperability (IOP) System Requirement & Validation using Eurocae ED133 first demonstration and validation activities are planned during 2012-2014 period and first developments in industrial systems are available from 2015.

It is anticipated that the initial implementation date in Europe between two ATSUs from two system providers and two ANSPs will occur between 2018 and 2020.

SESAR R&D projects on SWIM are in WP14 SWIM technical architecture and WP8 Information management.

United States – Flight Information Exchange Model will be standardized by 2018

## 8. Reference Documents

### 8.1 Standards

- EUROCAE ED-133, Flight Object Interoperability Standard
- [FF-ICE FIXM](#) SARPs (to be developed)

### 8.2 Procedures

### 8.3 Guidance Material

- FF-ICE Concept Document

### 8.4 Approval Documents

- ICAO Doc 4444, *Procedures for Air Navigation Services — Air Traffic Management*;
- EUROCAE ED-133, Flight Object Interoperability Standard

## Module N° B3-25 Improved Operational Performance through the introduction of Full FF-ICE

<b>Summary</b>	Data for all relevant Flights systematically shared between the air and ground systems using SWIM in support of collaborative ATM and Trajectory Based Operations.	
<b>Main Performance Impact</b>	KPA-04 Efficiency KPA-06 Flexibility, KPA-07 Global Interoperability, KPA-08 Participation by the ATM community, KPA-10 Safety,	
<b>Operating Environment/Phases of Flight</b>	All phases of flight from initial planning to post-flight	
<b>Applicability Considerations</b>	Air and ground	
<b>Global Concept Component(s)</b>	IM-information management	
<b>Global Plan Initiatives (GPI)</b>	GPI-7 Dynamic and flexible route management GPI-12 Functional integration of ground systems with airborne systems GPI-16 Decision Support Systems	
<b>Pre-Requisites</b>	B2-25, B2-31	
<b>Global Readiness Checklist</b>		<b>Status (ready now or estimated date)</b>
	Standards Readiness	Est 2023
	Avionics Availability	Est 2025
	Ground Systems Availability	Est 2025
	Procedures Available	Est 2025
	Operations Approvals	Est 2025

## 1. Narrative

Refer to ICAO Draft Brochure: FLIGHT & FLOW INFORMATION FOR A COLLABORATIVE ENVIRONMENT (FF-ICE) - A Concept to Support Future ATM systems.

- **The Role of FF-ICE:** As a product of the ICAO Global ATM Concept, FF-ICE defines information requirements for flight planning, flow management and trajectory management and aims to be a cornerstone of the performance-based air navigation system. Flight information and associated trajectories are principal mechanisms by which ATM service delivery will meet operational requirements.

FF-ICE will have global applicability and will support all members of the ATM community to achieve strategic, pre-tactical and tactical performance management.

FF-ICE emphasizes the need for information sharing to enable significant benefits.

The exchange of flight/flow information will assist the construction of the best possible integrated picture of the past, present and future ATM situation. This exchange of information enables improved decision making by the ATM actors involved in the entire duration of a flight, i.e. gate-to-gate, facilitating management of the full 4-D trajectory.

FF-ICE ensures that definitions of data elements are globally standardized and provides the mechanisms for their exchange. Thus, with appropriate information management a Collaborative Decision Making environment is created enabling the sharing of appropriate data across a wider set of participants resulting in greater coordination of the ATM community, situational awareness and the achievement of global performance targets.

The future collaborative and dynamic flight information process will involve the full spectrum of ATM Community members as envisaged in the ATM Global Operational Concept. The cornerstone of future air traffic management is the interaction between these various parties and FF-ICE allows dynamic exchange of information.

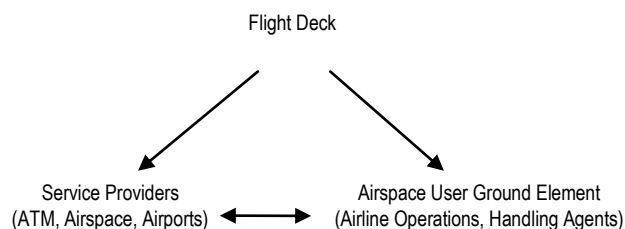

The Global ATM concept, implemented through regional programmes such as SESAR (Single European Sky ATM Research) in Europe, NextGen (Next Generation Air Transportation System) in North America and CARATS (Collaborative Action for Renovation of Air Traffic Systems) in Japan, foresees Air Traffic Control becoming traffic management by trajectory. The roles of the parties illustrated above will evolve to support the requirements of this concept which will:

- Entail systematic sharing of aircraft trajectory data between actors in the ATM process
- Ensure that all actors have a common view of a flight and have access to the most accurate data available
- Allow operations respecting the airspace users' individual business cases
- Improvement of the performance of aeronautical Search and Rescue Services (JAPAN)

### The Need for Change

The Global ATM Concept envisages an integrated, harmonized and globally interoperable system for all users in all phases of flight. The aim is to increase user flexibility and maximize operating

efficiencies while increasing system capacity and improving safety levels in the future ATM system. The current system, including the flight planning process, has many limitations. [FF-ICE](#) helps to address these limitations and establishes the environment to enable improvements such as:

- Reduced reliance on voice radio communications for air/ground links
- Increased collaborative planning amongst ATM actors
- Providing facilities for real time information exchange
- Maximizing benefits of advanced equipment and encouraging deployment of improved air and/or ground systems

## 1.1 General

### 1.1.1 Baseline

FF-ICE step 1 is implemented and initial SWIM applications are available on the ground as a result of modules B2-25 and B1-31. Flight-Object has been deployed as basis of the new [FDP](#) systems.

### 1.1.2 Change brought by the module

The module brings a new way to exchange trajectory data to provide better ATM services to airspace users.

Flight-object will be implemented in the ground systems and will support the flight information and trajectory sharing through SWIM during all phases of flight between air and ground. All messages between air and ground systems will use XML format to facilitate development and evolution.

The main challenge is to implement FF-ICE in airborne systems and use SWIM for airborne access to ATM information.

## 2. Intended Performance Operational Improvement

Metrics to determine the success of the module are proposed at Doc 9883.

<i>Efficiency</i>	Better knowledge of trajectory information will allow more optimum flight profile.
<i>Global Interoperability</i>	Global interoperability is facilitated by easier connection of all stakeholders
<i>Participation by the ATM community</i>	Participation of all stakeholders is facilitated through real-time data sharing
<i>Predictability</i>	The sharing of information between aircraft and ground systems will enhance the predictability
<i>Safety</i>	System wide data sharing will allow early detection of inconsistencies and updated information which will improve situation awareness.

<a href="#">CBA</a>	To be demonstrated by the balance of cost of system change with other performance improvement.
---------------------	--

## 3. Necessary Procedures (Air & Ground)

Publish and subscribe mechanisms will allow real-time sharing of the Flight Information for concerned and authorized actors.

The use of these data will be mainly for decision making tools and further automation.

## 4. Necessary System Capability

### 4.1 Avionics

Connection of the Flight Deck systems to the ground systems through a high speed data communication system.

Necessary distributed applications to manage the new services

## **4.2 Ground Systems**

There is a need for full secure and high throughput ground-ground and air-ground communications networks supporting SWIM access for exchange of Flight and Flow information from planning phase to post-Flight phase.

Necessarily distributed applications to manage the new services.

## **5. Human Performance**

### **5.1 Human Factors Considerations**

**5.1.1** This technological evolution does not affect directly the pilots or controllers and could be transparent. (System to system exchange, more accurate and updated data) however, this module is still in the research and development phase so the human factors considerations are still in the process of being identified through modelling and beta testing. Future iterations of this document will become more specific about the processes and procedures necessary to take the human factors considerations into account. There will be a particular emphasis on identifying the human-machine interface issue if there are any and providing the high risk mitigation strategies to account for them.

### **5.2 Training and Qualification Requirements**

**5.2.1** Training of pilot, controller to use the new services associated to decision support tools through new procedures. This module will eventually contain and number of personnel training requirements. As and when they are developed, they will be included in the documentation supporting this module and their importance signified. Likewise, any qualifications requirements that are recommended will become part of the regulatory needs prior to implementation of this performance improvement

## **6. Regulatory/standardization needs and Approval Plan (Air & Ground)**

- **Regulatory/Standardization:** Updates required to current published requirements given in Section 8.4
- **Approval Plans:** To Be Determined.

## **7. Implementation and Demonstration Activities**

### **7.1 Current Use**

None at this time

### **7.2 Planned or Ongoing Activities**

- Full-FF-ICE could be considered as the ultimate goal of the Trajectory Based Operations and it is part of NextGen and SESAR R&D plan.
- List of SESAR Projects: WP/14 and WP/8.

## **8. Reference Documents**

### **8.1 Standards**

### **8.2 Procedures**

### **8.3 Guidance Material**

- FF-ICE concept document
- Trajectory Based Operations documents

### **8.4 Approval Documents**

ICAO Doc 4444, *Procedures for Air Navigation Services — Air Traffic Management*

**Performance Improvement Area 2: Globally Interoperable Systems and Data - Through Globally Interoperable System Wide Information Management.**

***Thread: Digital Aeronautical Information Management***

This Page Intentionally Left Blank

## Module N° B0-30: Service Improvement through Digital Aeronautical Information Management

<b>Summary</b>	The initial introduction of digital processing and management of information, through <a href="#">AIS</a> /AIM implementation, use of <a href="#">AIXM</a> , migration to electronic <a href="#">AIP</a> and better quality and availability of data.	
<b>Main Performance Impact</b>	KPA-03 Cost-Effectiveness, KPA-05 Environment, KPA-07 Global Interoperability; KPA-10 Safety	
<b>Operating Environment/Phases of Flight</b>	All phases of flight	
<b>Applicability Considerations</b>	Applicable at State level, with increased benefits as more States participate	
<b>Global Concept Component(s)</b>	IM – Information Management	
<b>Global Plan Initiatives (GPI)</b>	GPI-18 Electronic information services	
<b>Pre-Requisites</b>	NIL	
<b>Global Readiness Checklist</b>		<b>Status (ready now or estimated date)</b>
	Standards Readiness	✓
	Avionics Availability	✓
	Ground Systems Availability	✓
	Procedures Available	✓
	Operations Approvals	✓

### 1. Narrative

#### 1.1 General

The subject has been discussed at the Eleventh Air Navigation Conference (Doc 9829, AN-Conf/11) which made the following recommendation:

Recommendation 1/8 — Global aeronautical information management and data exchange model

That ICAO:

- a) when developing ATM requirements, define corresponding requirements for safe and efficient global aeronautical information management that would support a digital, real-time, accredited and secure aeronautical information environment;
- b) urgently adopt a common aeronautical information exchange model, taking into account operational systems or concepts of data interchange, including specifically, [AICM/AIXM](#), and their mutual interoperability; and
- c) develop, as a matter of urgency, new specifications for Annexes 4 and 15 that would govern provision, electronic storage, on-line access to and maintenance of aeronautical information and charts.

The long term objective is the establishment of a network-centric information environment, also known as System Wide Information Management (SWIM).

In the short to medium term, the focus is on the definition and harmonized transition from the present Aeronautical Information Services (AIS) to Aeronautical Information Management (AIM). AIM envisages a migration from a focus on products to a data centric environment where aeronautical data will be provided in a digital form and in a managed way. This transition includes both static (AIP) and dynamic (NOTAM) data.



This can be regarded as the first stage of SWIM, which is based on common data models and data exchange formats. The next (long term) SWIM level implies the re-thinking of the data services from a “network” perspective, which in the first level remains a centralised State service.

The aeronautical information services must transition to a broader concept of aeronautical information management, with a different method of information provision and management given its data-centric nature as opposed to the product-centric nature of AIS.

The expectations are that the transition to AIM will not involve many changes in terms of the scope of information to be distributed. The major change will be the increased emphasis on data distribution, which should place the future AIM in a position to better serve airspace users and ATM in terms of their information management requirements.

This is the first step towards SWIM. This first step is easy to make because it concerns information that is static or does not change often, yet it generates substantial benefits even for small States. It provides initial experience before making further steps towards full-SWIM.

### 1.1.1 Baseline

The baseline is the traditional aeronautical information service and processes, based on paper publications and NOTAMs.

AIS information published by the ICAO Member States has traditionally been based on paper documents and text messages (NOTAM) and maintained and distributed as such. In spite of manual verifications, this did not always prevent errors or inconsistencies. In addition, the information had to be recaptured from paper to ground and airborne systems, thus introducing additional risks. Finally, the timeliness and quality of more dynamic information could not always be guaranteed.

### 1.1.2 Change brought by the module

The module makes AIS move into AIM, with standardized formats based on widely used information technology standards (UML, XML/GML), supported by industrial products and stored on electronics devices. Information quality is increased, as well as that of the management of aeronautical information in general. The [AIP](#) moves from paper to electronic support.

## 2. Intended Performance Operational Improvement

**Metrics to determine the success of the module are proposed in the *Manual on Global Performance of the Air Navigation System (Doc 9883)*.**

<i>Cost Effectiveness</i>	Reduced costs in terms of data inputs and checks, paper and post, especially when considering the overall data chain, from originators, through AIS, to the end users.
<i>Environment</i>	Reduced use of paper; also, more dynamic information should allow shorter flight trajectories, based on more accurate information about the current status of the airspace structure.
<i>Global Interoperability</i>	Essential contribution to interoperability
<i>Safety</i>	Reduction in the number of possible inconsistencies. Module allows to reduce the number of manual entries and ensures consistency among data through automatic data checking based on commonly agreed business rules.

<a href="#">CBA</a>	The business case for <a href="#">AIXM</a> has been conducted in Europe and in the United States and has shown to be positive. The initial investment necessary for the provision of digital AIS data may be reduced through regional cooperation and it remains low compared with the cost of other ATM systems. The transition from paper products to digital data is a critical pre-requisite for the implementation of any current or future ATM or air navigation concept that relies on the accuracy, integrity and timeliness of the data.
---------------------	---

### 3. Necessary Procedures (Air & Ground)

No new procedures for ATC are required, but the process for [AIS](#) needs to be revisited. Full benefit requires new procedures for data users in order to retrieve the information digitally. For example, to allow airlines provide digital AIS data to on-board devices, in particular electronic flight bags (EFBs).

### 4. Necessary System Capability

#### 4.1 Avionics

No avionics requirements.

#### 4.2 Ground Systems

The AIS information is made available to the AIS service through IT and to external users via either a subscription to an electronic access or physical delivery; the electronic access can be based on internet protocol services. The physical support does not need to be standardized. The main automation functions that need to be implemented to support provision of electronic AIS are the national aeronautical data, NOTAM (both national and international) and meteorological management including data collection, verification and distribution.

### 5. Human Performance

#### 5.1 Human Factors Considerations

**5.1.1** The automated assistance is proven to be well accepted and tend to reduce errors in manual transcription of data.

**5.1.2** Human Factors have been taken into consideration during the development of the processes and procedures associated with this module. Where automation is to be used, the Human-Machine interface has been considered from both a functional and ergonomic perspective (See Section 6 for examples). The possibility of latent failures however, continues to exist and vigilance is requested during all implementation actions. It is further requested that human factor issues, identified during implementation, be reported to the international community through ICAO as part of any safety reporting initiative.

#### 5.2 Training and Qualification Requirements

**5.2.1** Training is required for AIS/AIM personnel. Training in the operational standards and procedures are required for this module and can be found in the links to the documents in Section 8 to this module. Likewise, the qualifications requirements are identified in the regulatory requirements in Section 6 which form an integral part to the implementation of this module.

### 6. Regulatory/standardization needs and Approval Plan (Air & Ground)

- **Regulatory/Standardization:** Use current published requirements that includes material given in Section 8.4.
- **Approval Plans:** To Be Determined, based upon regional applications.

### 7. Implementation and Demonstration Activities

#### 7.1 Current Use

- **Europe:** the European [AIS](#) Database (EAD) became operational in June 2003. Electronic [AIP](#) (eAIP), fully digital versions of the paper document and based on a EUROCONTROL eAIP specification have been implemented (on-line or on a CD) in a number of States (e.g. Armenia, Belgium & Luxemburg, Hungary, Jordan, Latvia, Moldova, Netherlands, Portugal, Slovak Republic, Slovenia, etc.). Both are essential milestones in the realization of the digital environment. The EAD had been developed using the Aeronautical Information Conceptual Model (AICM) and Aeronautical Information Exchange Model (AIXM). Some European states have chosen to implement their own AIM solution instead. This is for example the case for France AIS which operates its own AIM system called NOPIAUS: Digital NOTAM is currently deployed and in use in the US using the AIXM 4.0.
- **Other regions** Azerbaijan, Japan, Jordan, Taiwan have implemented the eAIP. Mongolia: TBC

- [AIXM](#) based system recently ordered several countries around the world, including Australia, Canada, South Africa, Brazil, India, Fiji, Singapore, ASECNA, Panama etc.

## **7.2 Planned or Ongoing Activities**

The current trials in Europe and USA focus on the introduction of Digital NOTAM, which can be automatically generated and used by computer systems and do not require extensive manual processing, as compared with the text NOTAM of today. More information is available on the EUROCONTROL and FAA Web sites:

[http://www.EUROCONTROL.int/aim/public/standard\\_page/xnotam.html](http://www.EUROCONTROL.int/aim/public/standard_page/xnotam.html) and  
<http://notams.aim.faa.gov/fnsstart/>.

Planned compliance with AIXM v5.x when new version is finalized.

## **8. Reference Documents**

### **8.1 Standards**

TBD

### **8.2 Procedures**

TBD

### **8.3 Guidance Material**

- ICAO Doc 8126, *Aeronautical Information Services Manual*, incl. AIXM and eAIP as per Edition 3;
- ICAO Doc 8697, *Aeronautical Chart Manual*; and
- Manuals on AIM quality system and AIM training.

## Module N° B1-30: Service Improvement through Integration of all Digital ATM Information

<b>Summary</b>	To implement the ATM information reference model integrating all ATM information using common formats (UML/XML and WXXM for meteorological information and FIXM for flight and flow information) and internet protocols.	
<b>Main Performance Impact</b>	KPA-01 Access & Equity; KPA-03 Cost-Effectiveness; KPA-07 Global Interoperability; KPA-10 Safety; KPA-11 Security	
<b>Operating Environment/Phases of Flight</b>	All phases of flight	
<b>Applicability Considerations</b>	Applicable at State level, with increased benefits as more States participate	
<b>Global Concept Component(s)</b>	IM – Information Management	
<b>Global Plan Initiatives (GPI)</b>	GPI-18 Electronic information services	
<b>Pre-Requisites</b>	B0-30 Parallel progress with: B1-25, B1-31	
<b>Global Readiness Checklist</b>		<b>Status</b> (ready now or estimated date)
	Standards Readiness	<b>Est. 2018</b>
	Avionics Availability	<b>NA</b>
	Ground Systems Availability	<b>Est. 2018</b>
	Procedures Available	✓
	Operations Approvals	<b>Est. 2018</b>

### 1. Narrative

#### 1.1 General – eTOD, AMDB, Electronic Aero Chart, Digital NOTAM to be explicitly included (JAPAN)

The module captures two main actions which capitalize on the advances made in the previous block on the same subject. The module will implement the ATM Information Reference Model (AIRM) capturing **all** the types of information used by ATM in a consistent set of data and service models (using UML, GML/XML) and that can be accessed via internet protocol based tools. The module also implements a second step of digital information management, with exchange data models for meteorological information (WXXM), flight and flow information (FIXM) and aircraft performance related data.(JAPAN) The further standardization of aircraft performance data is also to be considered.

##### 1.1.1 Baseline

The baseline at the implementation level is the use of [AIXM](#) for [AIS](#) data, resulting from module B0-30. The AIXM, the WXXM, and FIXM models are compatible with the AIRM.

##### 1.1.2 Change brought by the module

This module expands the approach pioneered by AIXM to the other forms of information by providing the overall reference model framework, allowing each type of data to fit into a consistent picture, the implementation of AIXM providing the foundation for many data that refer to AIM data. It also proceeds with the additional capability to manage, distribute and process the weather, possibly flight & flow and aircraft

performance related data. In addition to interoperable data, the module starts to provide interoperable information services as part of the transition to a Service Oriented Architecture.

## 2. Intended Performance Operational Improvement

Metrics to determine the success of the module are proposed in the *Manual on Global Performance of the Air Navigation System (Doc 9883)*.

<i>Access and Equity</i>	Greater and timelier access to up-to-date information by a wider set of users.
<i>Cost Effectiveness</i>	Reduction of time to process a new piece of information; reduced use of paper; higher agility of the system to create new applications through the availability of standardized data.
<i>Global Interoperability</i>	Essential for global interoperability.
<i>Safety</i>	Reduced probability of error or inconsistency in/across data; reduced possibility to introduce additional errors by subsequent manual inputs.
<i>Security</i>	Information security considerations are embedded in the developments.

<a href="#">CBA</a>	Business case to be established in the course of the projects defining the models and their possible implementation.
---------------------	--

## 3. Necessary Procedures (Air & Ground)

No new procedures for ATM, but a revisited process for management of information.

## 4. Necessary System Capability

### 4.1 Avionics

AWAIT Material from Didier.

### 4.2 Ground Systems

All users/producers of the information need to implement [AIRM](#) in support of their exchanges with other members of the ATM community.

## 5. Human Performance

### 5.1 Human Factors Considerations

**5.1.1** The use of a common model supported by the industrial IT tools is of a nature reduce errors in manual transcription of data and in the management of information.

**5.1.2** The identification of Human Factors considerations is an important enabler in identifying processes and procedures for this module. In particular, the human-machine interface for the automation aspects of this performance improvement will need to be considered and where necessary accompanied by mitigation risk mitigation strategies such as training, education and redundancy.

### 5.2 Training and Qualification Requirements

**5.2.1** Training is required for personnel managing the ATM information and for their users if the interfaces and access conditions change.

**5.2.2** Training in the operational standards and procedures will be identified along with the standards and recommended practices necessary for this module to be implemented. Likewise the qualifications requirements will be identified and included in the regulatory readiness aspects of this module when they become available.

## 6. Regulatory/standardization needs and Approval Plan (Air & Ground)

- **Regulatory/Standardization:** New standards and guidance needed to address all formatting/template type information including that given in Section 8.4.
- **Approval Plans:** To Be Determined

## 7. Implementation and Demonstration Activities

### 7.1 Current Use

None identified

### 7.2 Planned or Ongoing Activities

- **SESAR:** SESAR is currently defining and validating the ATM Information Reference Model (AIRM) & Information Service Reference Model (ISRM) including the specific data models: Aeronautical Information Exchange Model (AIXM), Weather Exchange model (WXXM), Flight Information Exchange Model (FIXM).
- **US:** This is covered through the EA OV-7 and associated service model activities of the NextGen programme.
- US-Europe cooperation is in place on the joint development and maintenance of the data models [AIXM/WXXM/FIXM](#)
- AIXM – FAA and JCAB is planning on demonstrating AIM capabilities in 2013.
- FIXM – US is also validating standards within internal automation systems.
- FIXM – Validating fleet prioritization information exchange with US Carriers.
- FIXM – UAS 4D Trajectory demonstration validated initial feasibility of trajectory based operations using initial FIXM standard for air-ground exchange of flight information.
- FIXM/AIXM – Mini Global – US/Europe/Pacific – validating the use of exchange standards across European, Asian, and US Systems.
- WXXM – FAA – Demonstrated a “publish and subscribe” capability to exchange weather information between the FAA and National Weather Service.

## 8. Reference Documents

### 8.1 Standards

- ICAO Doc 8126, *Aeronautical Information Services Manual*
- New PANS-AIM document (2016) to address all formatting/template type information of Annex 15, Aeronautical Information Services

### 8.2 Procedures

### 8.3 Guidance Material

### 8.4 Approval Documents

- Annex 15
- Doc8126
- PANS-AIM due for publication in 2016.

**Performance Improvement Area 2: Globally Interoperable Systems and Data - Through Globally Interoperable System Wide Information Management.**

***Thread: System Wide Information Management***

This Page Intentionally Left Blank



## Module N° B1-31: Performance Improvement through the application of System Wide Information Management (SWIM)

<b>Summary</b>	Implementation of SWIM services (applications and infrastructure) creating the aviation intranet based on standard data models, and internet-based protocols to maximize interoperability.	
<b>Main Performance Impact</b>	KPA-03 Cost-Effectiveness, KPA-04 Efficiency KPA-05 Environment, KPA-10 Safety; KPA-11 Security,	
<b>Operating Environment/Phases of Flight</b>	All phases of flight	
<b>Applicability Considerations</b>	Applicable at State level, with increased benefits as more States participate	
<b>Global Concept Component(s)</b>	IM – Information Management	
<b>Global Plan Initiatives (GPI)</b>	GPI-18 Electronic information services	
<b>Pre-Requisites</b>	Successor of: B0-30 Parallel progress with: B1-30	
<b>Global Readiness Checklist</b>		<b>Status</b> (ready now or estimated date)
	Standards Readiness	<b>Est. 2016</b>
	Avionics Availability	<b>NA</b>
	Ground Systems Availability	<b>Est. 2018</b>
	Procedures Available	<b>Est. 2016</b>
	Operations Approvals	<b>Est. 2016</b>

### 1. Narrative

#### 1.1 General

A goal of the Global ATM Operational Concept is a net-centric operation where the ATM network is considered as a series of nodes, including the aircraft, providing or using information. Aircraft operators with operational control centre facilities will share information while the individual user will be able to do the same via applications running on any suitable personal device. The support provided by the ATM network will in all cases be tailored to the needs of the user concerned.

The sharing of information of the required quality and timeliness in a secure environment is an essential enabler to the ATM Target Concept. The scope extends to all information that is of potential interest to ATM including trajectories, surveillance data, aeronautical information of all types, meteorological data etc. In particular, all partners in the ATM network will share trajectory information in real time to the extent required from the trajectory development phase through operations and post-operation activities. ATM planning, collaborative decision making processes and tactical operations will always be based on the latest and most accurate trajectory data. The individual trajectories will be managed through the provision of a set of ATM services tailored to meet their specific needs, acknowledging that not all aircraft will (or will need to) be able to attain the same level of capability at the same time.

SWIM is an essential enabler for ATM applications which provides an appropriate infrastructure and ensures the availability of the information needed by the applications run by the users. The related geo / time enabled, seamless and open interoperable data exchange relies on the use of common methodology and the use of a suitable technology and compliant system interfaces. The availability of SWIM will make

possible the deployment of advance end-user applications as it will provide extensive information sharing and the capability to find the right information wherever the provider is.

The phased approach to the deployment of SWIM has been developed to ensure that benefits start of be realised at the earliest possible time by integrating simple end-user applications first. The deployment of SWIM is not dependent on the deployment of ATM changes, benefits can be achieved in largely legacy environments though regulations might be required notably concerning the liability, use rights and intellectual property rights aspects of data provision.

At each stage, the phased implementation of SWIM will consider the three inter-related dimensions (applications, information and infrastructure):

- Applications represent the user side of SWIM. They will be addressed through the identification of “communities of interest” gathering stakeholders that have to share information to serve their interests. The partners in the community know the information they need to share with what quality of service and for effective collaboration they require a common understanding of the information and the information has to be available in a commonly agreed structure. Initially the communities will comprise a core of airports and aircraft operators evolving to include more complex collaborations across the whole ATM business chain.
- Information covers both the semantic and syntactic aspects of data composing information and the Information Management functions. The former is dealt with by modelling activities which aim to use and or define common standards while the latter include mainly distribution, quality, maintenance, user identity and profile to enable data exchange and sharing within a community of interest and between communities independently of the underlying communication infrastructure.
- Infrastructure will be concerned mainly by the connectivity aspects: It will be built on existing legacy infrastructure as far as practicable until an [IP](#) based network communications is available. The air/ground segment is an example of SWIM connectivity that is intended to be added at a later stage as aircraft are integrated into the communities of interest (see B1-40).

The combination of the above three areas at particular stages of their common evolution constitute the ATM Capability Levels for Information Management.

### 1.1.1 Baseline

Module B0-30 will have created a nucleus of modern information management and provided experience to move forward in domains other than AIM. Module B1-30 will in parallel allow ATM information to be structured and managed in fully digital and consistent manner, using the same standards for their description. B0-30 remained a traditional environment where information needed to be requested or was the subject of distribution via classical subscriptions. It was not adapted to the fully dynamic environment that ATM is about, and therefore is started with information not considered as safety critical and/or integrated with other data.

### 1.1.2 Change brought by the module

This module allows, thanks to the notion of SWIM, to ensure that the right, up-to-date and accurate data is timely available to the right user with the required performance and quality. It represents the achievement of a significant paradigm shift in ATM and is the enabler, together with the appropriate telecommunication infrastructure, of the most advanced features of the Global concept, in particular seamless trajectory based operations.

The module addresses applications of SWIM on the ground. Most of the air ground data exchanges will remain based on point-to-point communication.

## 2. Intended Performance Operational Improvement

**Metrics to determine the success of the module are proposed in the *Manual on Global Performance of the Air Navigation System (Doc 9883)*.**

<i>Cost Effectiveness</i>	further reduction of costs; all information can be managed consistently across the network, limiting bespoke developments, flexible to adapt to state-of-the-art industrial products and making use of scale economies for the exchanged volumes
<i>Efficiency</i>	Using better information allows operators and service providers to plan

	and execute better trajectories
<i>Environment</i>	further reduction of paper usage more cost-efficient flights as the most up to date is available to all stakeholders in the ATM system
<i>Safety</i>	access protocols and data quality will be designed to reduce current limitations in these area
<i>Security</i>	access protocols and data quality will be designed to reduce current limitations in these area

<a href="#">CBA</a>	The business case is to be considered in the full light of other modules of this block and the next one. Pure SWIM aspects unlock ATM information management issues; operational benefits are more indirect
---------------------	---

### 3. Necessary Procedures (Air & Ground)

SWIM implies new procedures regarding access to and delivery of information. While most of them should be transparent to tactical ATC functions, there will be a need to be able to distinguish, at least during a transition period, those operators which will be able to access and deliver information via SWIM from those which still need less advanced modes.

### 4. Necessary System Capability

#### 4.1 Avionics

No avionics requirement.

#### 4.2 Ground Systems

The ground SWIM infrastructure (i.e. inter-networking between stakeholders and communication protocols) and its oversight functions to allow the progressive connection of ATM stakeholder systems while meeting the necessary safety, security and reliability requirements. The ATM stakeholder systems adaptation will vary from low to high depending on their architecture and their ability to transform this architecture into a concrete Service Oriented one.

### 5. Human Performance

#### 5.1 Human Factors Considerations

**5.1.1** SWIM is a new concept to address information and its use. In essence it is close to the notion of an intranet. It therefore needs to be understood as such by all personnel, which will need to be aware of the principles and conditions of use. In addition, the architecture (logical and physical) and the management of the information data will be different from today and affect those that were in charge of these functions. End-users will be affected only if their access to data via interfaces does not remain stable.

**5.1.2** The identification of Human Factors considerations is an important enabler in identifying processes and procedures for this module. In particular, the human-machine interface for the automation aspects of this performance improvement will need to be considered and where necessary accompanied by mitigation risk mitigation strategies such as training, education and redundancy

## 5.2 Training and Qualification Requirements

**5.2.1** Training requirements will be required and will have a high necessity. (JAPAN). Training in the operational standards and procedures will be identified along with the standards and recommended practices necessary for this module to be implemented. Likewise the qualifications requirements will be identified and included in the regulatory readiness aspects of this module when they become available

## 6. Regulatory/standardization needs and Approval Plan (Air & Ground)

- **Regulatory/Standardization:** New standards and guidance needed to address all formatting/template type information including that given in Section 8.4;
- **Approval Plans:** To Be Determined.

## 7. Implementation and Demonstration Activities

### 7.1 Current Use

- **Europe:** use of [PENS](#) as backbone for IP ground-ground communications, but currently with no SWIM application. Use of [CFMU NOP](#) Portal Web services and [EAD](#) AIM services.
- **United States:** Using SWIM with FTI Backbone (TCP/IP) sharing of data such as terminal weather data, and special activity airspace information will be implemented in 2013.

### 7.2 Planned or Ongoing Activities

- **SESAR:**
  - SWIM Step1 infrastructure demonstration by the end of 2011
  - Planned Release 2 V&V SWIM-enabled exercises :
    - IOP Validation”: ATC-ATC Coordination by means of a new mechanism based on the Flight Object
    - Validation of the first AIM service through SWIM using a [AIXM5](#) data simulator
    - “Slot Swapping”: [DMEAN](#) implemented improvement (slot swapping). Prototype of enhanced slot swapping function to cover extension to all flights from/to a given airport.
    - “AIMQuick win (Step1)”: Validate new ways of publishing complex up-to-date aeronautical information based on the Digital NOTAM concept with its particular temporality data representation.
  - SESAR trials in 2013-16 for SWIM protocols and prototype
- **United States:** Flight Data Publication and Additional weather information are currently being planned to be on-ramped enabling publication / subscription and registry capabilities

## 8. Reference Documents

### 8.1 Standards

- ICAO Doc 8126, *Aeronautical Information Services Manual*;
- New PANS-AIM document (2016) to address all formatting/template type information of Annex 15, Aeronautical Information Services.

### 8.2 Procedures

### 8.3 Guidance Material

- WXXM

### 8.4 Approval Documents

- Annex 15;
- Doc8126;
- PANS-AIM due for publication in 2016.

## Module N° B2-31: Enabling Airborne Participation in collaborative ATM through SWIM

<b>Summary</b>	This allows the aircraft to be fully connected as an information node in SWIM, enabling full participation in collaborative ATM processes with access to voluminous dynamic data including meteorology. This will start with non-safety critical exchanges supported by commercial data links	
<b>Timescale</b>	From 2023	
<b>Main Performance Impact</b>	KPA-01 Access & Equity, KPA-04 Efficiency, KPA-05 Environment, KPA-08 Participation by the ATM Community, KPA-09 Predictability, KPA-10 Safety	
<b>Operating Environment / Flight Phases</b>	All phases of flight	
<b>Applicability Considerations</b>	long-term evolution potentially applicable to all environments	
<b>Global Concept Component(s)</b>	IM – Information Management	
<b>Global Plan Initiatives (GPI)</b>	GPI-17 Implementation of data link applications GPI-18 Electronic information services	
<b>Main Dependencies</b>	B1-30, B1-31, B1-80, B1-105,	
<b>Global Readiness Checklist</b>		<b>Status (ready or date)</b>
	Standards Readiness	<b>2023</b>
	Avionics Availability	<b>2023</b>
	Infrastructure Availability	<b>2023</b>
	Ground Automation Availability	<b>2023</b>
	Procedures Available	<b>2023</b>
	Operations Approvals	<b>2023</b>

### 1. Narrative

#### 1.1 General

The Global concept envisages that the aircraft is an integral part of the collaborative, information-rich ATM environment. This ultimately makes it a regular node of the SWIM processes and infrastructure, able to participate in the 4D trajectory management and collaborative processes. Enabling the aircraft to participate in SWIM is the availability of a low cost data link capability for strategic information exchange.

##### 1.1.1 Baseline

Modules B1-30 and B1-31 have created the ground SWIM infrastructure and the information reference model, and implemented processes and applications for ground users. Through datalinks such as WiMax, a high capacity data link exists for aircraft at the gate (end of pre-flight phase). Aviation, motivated first by non-ATM needs, has access to commercial satellite communication.

##### 1.1.2 Change brought by the module

This module allows the aircraft to be fully connected as an information node in SWIM, enabling full participation in collaborative ATM processes with access to voluminous dynamic data including meteorology, initially for non-safety critical exchanges supported by commercial data links. The applications of this module are integrated into the processes and the information infrastructure which had evolved over the previous blocks.

The module can then evolve smoothly to the use of other technologies as they become available for the air-ground link when the aircraft is airborne. To enable the Collaborative ATM, and meteorological information exchange capabilities in this module, network access on the aircraft is required on the ground and in the air. However, since these capabilities are not safety-critical, the security and reliability requirements are lower than those of critical systems such as the VDL network, a commercial system utilizing cell-based or satellite based internet services could be used.

## 2. Intended Performance Operational Improvement/Metric to determine success

Metrics to determine the success of the module are proposed in the *Manual on Global Performance of the Air Navigation System (Doc 9883)*.

<i>Access and Equity</i>	Access by the aircraft to the ATM information environment
<i>Efficiency</i>	Better exploitation of meteorological and other operational (e.g. airport situation) information to optimize the trajectory
<i>Environment</i>	Better exploitation of meteorological information to optimize the trajectory
<i>Participation by the ATM community</i>	The aircraft becomes an integral part of continuous collaboration and of the overall information pool.
<i>Predictability</i>	Anticipation of situations affecting the flight through the access to relevant information
<i>Safety</i>	Anticipation of potentially hazardous or safety bearing situations affecting the flight through the access to relevant information

<a href="#"><u>CBA</u></a>	The business case will be established in the relevant validation programmes.
<i>Human Performance</i>	<p>A critical element is the integration of the new information processes in the tasks of the pilot; they may also affect the respective duties of the aircraft crew and the airline dispatchers.</p> <p>The use of the applications during demanding flight conditions will need careful investigation.</p> <p>Training will be required.</p>

## 3. Necessary Procedures (Air & Ground)

Procedures are to be defined. They will define the conditions of access to information and the use to supported applications depending on the characteristics of these and of the communication channels available, in particular safety, security and latency.

## 4. Necessary System Capability

### 4.1 Avionics

The enabling technologies are under development. The most important one is the availability of a suitable combination of air-ground data links to support safety- and non-safety applications

### 4.2 Ground Systems

The enabling technologies are under development.

## 5. Human Performance

### 5.1 Human Factors Considerations

**5.1.1** A critical element is the integration of the new information processes in the tasks of the pilot; they may also affect the respective duties of the aircraft crew and the airline dispatchers.

**5.1.2** The use of the applications during demanding flight conditions will need careful investigation. This module is still in the research and development phase so the human factors considerations are still in the process of being identified through modelling and beta testing. Future iterations of this document will become more specific about the processes and procedures necessary to take the human factors considerations into account. There will be a particular emphasis on identifying the human-machine interface issue if there are any and providing the high risk mitigation strategies to account for them.

## **5.2 Training and Qualification Requirements**

**5.2.1** This module will eventually contain a number of personnel training requirements. As and when they are developed, they will be included in the documentation supporting this module and their importance signified. Likewise, any qualifications requirements that are recommended will become part of the regulatory needs prior to implementation of this performance improvement

## **6. Regulatory/standardization needs and Approval Plan (Air & Ground)**

- **Regulatory/Standardization:** New standards and guidance needed to enable aircraft to participate as full information node, and full participation in collaborative ATM.
- **Approval Plans:** To Be Determined

## **7. Implementation and Demonstration Activities**

### **7.1 Current Use**

- None

### **7.2 Planned or Ongoing Trials**

- **United States** – Airborne Access to SWIM Simulations are planned to begin in 2012, with multiple operational trials occurring in 2013-2014. Expected specifications and performance requirements to be defined as part of trials

## **8. Reference Documents**

### **8.1 Standards**

### **8.2 Procedures**

### **8.3 Guidance Material**

- FF-ICE Manual (under development).

### **8.4 Approval Documents**

**Performance Improvement Area 2: Globally Interoperable Systems and Data - Through Globally Interoperable System Wide Information Management.**

***Thread: Improved Meteorological Information***



## Module N° B0-105: Meteorological information supporting enhanced operational efficiency and safety

<b>Summary</b>	<p>Global, regional and local meteorological information:</p> <ul style="list-style-type: none"> <li>• Aerodrome warnings to give concise information of meteorological conditions that could adversely affect all aircraft at an aerodrome including windshear.</li> <li>• Forecasts provided by world area forecast centres (WAFC), volcanic ash advisory centres (VAAC) and tropical cyclone advisory centres (TCAC)</li> </ul> <p>This information will support flexible airspace management, improved situational awareness and collaborative decision making, and dynamically-optimized flight trajectory planning</p>	
<b>Main Performance Impact</b>	<p>List of affected KPAs</p> <p>KPA-02 (Capacity); KPA-03 (Cost effectiveness); KPA-05 (Environment); KPA-06 (Flexibility); KPA-07 (Global interoperability);</p>	
<b>Operating Environment/ Phases of Flight</b>	<p>Single word entries explaining operating environment(s), i.e airport surface, etc. and/or phases of flight, i.e. approach, en-route, etc.</p> <p>All phases of flight.</p>	
<b>Applicability Considerations</b>	<p>Specifics on operating environment and/or types of airspace where Module is applicable</p> <p>Applicable to traffic flow planning, and to all aircraft operations in all domains and flight phases, regardless of level of aircraft equipage.</p>	
<b>Global Concept Component(s)</b>	<p>Up to three.</p> <p>AOM - Airspace Operations and Management</p> <p>DCB - Demand and Capacity Balancing</p> <p>AO - Aerodrome Operations</p>	
<b>Global Plan Initiatives (GPI)</b>	<p>Up to three</p> <p>GPI-19 Meteorological Systems</p> <p>GPI-6 Air Traffic Flow Management</p> <p>GPI-16 Decision Support Systems and Alerting Systems</p>	
<b>Pre-Requisites</b>	<p>Modules that must be implemented to support this module.</p> <p>None. Meteorological information and supporting distribution systems are in existence today.</p>	
<b>Global Readiness Checklist</b>		<b>Status</b> (ready now or estimated date).
	Standards Readiness	Ready now
	Avionics Availability	Ready now
	Ground System Availability	Ready now
	Procedures Available	Ready now
	Operations Approvals	Ready now

### 1. Narrative

#### 1.1 General

General description of the module with focus on the operational benefit or capability provided, operating environment and applicability

Elements 1 to 3 of this module illustrate the meteorological information made available by world area forecast centres (WAFc), volcanic ash advisory centres (VAAC) and tropical cyclone advisory centres (TCAC) respectively, within the frameworks of the world area forecast system (WAFS), international airways volcano watch (IAVW) and the tropical cyclone watch, that can be used by the air traffic management (ATM) community to support dynamic and flexible management of airspace, improved situational awareness and collaborative decision making, and (in the case of WAFS forecasts) dynamically-optimized flight trajectory planning.

Elements 4 and 5 of this module illustrate the meteorological information issued by aerodrome meteorological offices in the form of aerodrome warnings, wind shear warnings and alerts (including those generated by automated meteorological systems) that contribute to improving safety and maximizing runway capacity. In some instances, the systems used for the detection of wind shear (such as ground based [LIDAR](#)) have proven utility in wake turbulence detection and tracking/monitoring, and thus also support the improving safety and maximising runway capacity.

### 1.1.1 Baseline

Capability in place prior to the implementation of this module. This section is appropriate where the module provides an improvement over an existing capability.

WAFcs within the framework of the WAFS prepare global gridded forecasts of upper wind, upper-air temperature and humidity, geopotential altitude of flight levels, flight level and temperature of tropopause, direction, speed and flight level of maximum wind, cumulonimbus clouds, icing, and clear-air and in-cloud turbulence. These global gridded forecasts are issued 4-times per day, with fixed time validity T+0 to T+36 at 3-hour time-steps. In addition, the WAFcs prepare global forecasts of significant weather (SIGWX) phenomena in binary code form. These global forecasts of SIGWX phenomena are issued 4-times per day, with validity at T+24. The United Kingdom and United States are designated as WAFc provider States. Accordingly, WAFcs London and Washington make available the aforementioned forecasts on the ICAO Aeronautical Fixed Service (AFS).

VAACs within the framework of the IAVW respond to a notification that a volcano has erupted, or is expected to erupt or volcanic ash is reported in its area of responsibility. The VAACs monitor relevant satellite data to detect the existence and extent of volcanic ash in the atmosphere in the area concerned, and activate their volcanic ash numerical trajectory/dispersion model in order to forecast the movement of any ash cloud that has been detected or reported. The VAACs issue advisory information (in plain language textual form and graphical form) concerning the extent and forecast movement of the volcanic ash cloud, with fixed time validity T+0 to T+18 at 6-hour time-steps. The VAACs issue these forecasts at least every six hours until such time as the volcanic ash cloud is no longer identifiable from satellite data, no further reports of volcanic ash are received from the area, and no further eruptions of the volcano are reported. The VAACs maintain a 24-hour watch. Argentina, Australia, Canada, France, Japan, New Zealand, the United Kingdom and the United States are designated (by regional air navigation agreement) as the VAAC provider States. Accordingly, VAACs Buenos Aires, Darwin, Montreal, Toulouse, Tokyo, Wellington, London, Anchorage and Washington make available the aforementioned forecasts on the ICAO AFS.

TCACs within the framework of the tropical cyclone watch monitor the development of tropical cyclones in their area of responsibility, using satellite data, radar data and other meteorological information. The TCACs are meteorological centres designated by regional air navigation agreement on the advice of the World Meteorological Organization (WMO). The TCACs issue advisory information (in plain language textual form and graphical form) concerning the position of the tropical cyclone centre, its direction and speed of movement, central pressure and maximum surface wind near the centre, with fixed time validity T+0 to T+24 at 6-hour time-steps. The TCACs issue updated advisory information for each tropical cyclone, as necessary, but at least every six hours. Australia, Fiji, France, India, Japan and the United States are designated (by regional air navigation agreement) as TCAC provider States. Meteorological centres within these States make available the aforementioned forecasts on the ICAO AFS, through TCACs located in Darwin, Nadi, La Reunion, New Delhi, Tokyo, Honolulu and Miami.

Aerodrome warnings give concise information of meteorological conditions that could adversely affect aircraft on the ground, including parked aircraft, and the aerodrome facilities and services.

Wind shear warnings are prepared for aerodromes where wind shear is considered a factor. Wind shear warnings give concise information on the observed or expected existence of wind shear which could adversely affect aircraft on the approach path or take-off path or during circling approach between runway level and 500 m (1,600 ft) above that level and aircraft on the runway during the landing roll or take-off run.

Note that where local topography has been shown to produce significant wind shears at heights in excess of 500 m (1,600 ft) above runway level, then 500 m (1,600 ft) is not to be considered restrictive.

### **1.1.2 Change brought by the module**

Additional information on the operational benefit or capability plus any significant change to operations.

The global availability of meteorological information provided by designated Centres within the WAFS, IAVW and the tropical cyclone watch (as described above and principally in the form of forecast information) on the ICAO AFS enhances pre-tactical and/or tactical decision making for aircraft surveillance, air traffic flow management and flexible/dynamic aircraft routing. The locally-arranged availability of aerodrome warnings, wind shear warnings and alerts (where wind shear is considered a factor), contributes to improved safety and maximized runway capacity during adverse meteorological conditions. Wind shear detection systems can, in some instances, be utilised for wake turbulence detection and tracking/monitoring.

#### **1.1 Element 1: WAFS**

The WAFS is a worldwide system within which two designated WAFCs provide aeronautical meteorological en-route forecasts in uniform standardized formats. The grid point forecasts are prepared by the WAFCs in a regular grid with a horizontal resolution of 1.25 degrees of latitude and longitude, and issued in binary code form using the GRIB code form as prescribed by WMO. The significant weather (SIGWX) forecasts are issued by the WAFCs in accordance with the provisions in Annex 3 (Chapter 3 and Appendix 2) in binary code form using the BUFR code form prescribed by WMO. ICAO administers the WAFS with the cooperation of the WAFS provider States and concerned international organizations through the World Area Forecast System Operations Group (WAFSOPSG).

#### **1.2 Element 2: IAVW**

The IAVW ensures international arrangements for monitoring and providing warnings to aircraft of volcanic ash in the atmosphere. The IAVW is based on the cooperation of aviation and non-aviation operational units using information derived from observing sources and networks that are provided by States for the detection of volcanic ash in the atmosphere. The forecasts issued by the nine designated VAACs are in plain language text and PNG chart form. The advisory information on volcanic ash is prepared by VAACs in accordance with Annex 3 (Chapter 3 and Appendix 2). ICAO administers the IAVW with the cooperation of the VAAC provider States and concerned international organizations through the International Airways Volcano Watch Operations Group (IAVWOPSG).

#### **1.3 Element 3: Tropical cyclone watch**

The tropical cyclone watch ensures international arrangements for monitoring the formation, movement and degradation of tropical cyclones. The forecasts issued by the TCACs are in plain language text and graphical form. The advisory information on tropical cyclones is prepared by TCACs in accordance with Annex 3 (Chapter 3 and Appendix 2).

#### **1.4 Element 4: Aerodrome warnings**

Aerodrome warnings give concise information of meteorological conditions that could adversely affect aircraft on the ground, including parked aircraft, and the aerodrome facilities and services. Aerodrome warnings are issued in accordance with Annex 3 (Chapter 7 and Appendix 6) where required by operators or aerodrome services. Aerodrome warnings should relate to the occurrence or expected occurrence of one or more of the following phenomena: tropical cyclone, thunderstorm, hail, snow, freezing precipitation, hoar frost or rime, sandstorm, dust-storm, rising sand or dust, strong surface wind and gusts, squall, frost, volcanic ash, tsunami, volcanic ash deposition, toxic chemicals, and other phenomena as agreed locally. Aerodrome warnings are issued usually for validity periods of not more than 24 hours. Aerodrome warnings are disseminated within the aerodrome in accordance with local arrangements to those concerned, and should be cancelled when the conditions are no longer occurring and/or no longer expected to occur at the aerodrome.

#### **1.5 Element 5: Wind shear warnings and alerts**

Wind shear warnings are prepared for aerodromes where wind shear is considered a factor. Wind shear warnings give concise information on the observed or expected existence of wind shear which could adversely affect aircraft on the approach path or take-off path or during circling approach between runway level and 500 m (1,600 ft) above that level and aircraft on the runway during the landing roll or take-off run.

Where local topography has been shown to produce significant wind shears at heights in excess of 500 m (1,600 ft) above runway level, then 500 m (1,600 ft) must not be considered restrictive.

Wind shear warnings are issued in accordance with Annex 3 (Chapter 7 and Appendix 6) and disseminated within the aerodrome in accordance with local arrangements to those concerned. Wind shear conditions are normally associated with the following phenomena: thunderstorms, microbursts, funnel cloud (tornado or waterspout), and gust fronts, frontal surfaces, strong surface winds coupled with local topography; sea breeze fronts, mountain waves (including low-level rotors in the terminal area) and low-level temperature inversions.

At aerodromes where wind shear is detected by automated, ground-based, wind shear remote-sensing or detection equipment, wind shear alerts generated by these systems are issued. Wind shear alerts give concise, up-to-date information related to the observed existence of wind shear involving a headwind/tailwind change of 7.5 m/s (15 kt) or more which could adversely affect aircraft on the final approach path or initial take-off path and aircraft on the runway during the landing roll or take-off run. Wind shear alerts should be updated at least every minute. Wind shear alerts are disseminated from automated, ground-based, wind shear remote-sensing or detection equipment in accordance with local arrangements to those concerned.

In some instances, the systems used for the detection of wind shear have proven utility in wake turbulence detection and tracking/monitoring. This may prove especially beneficial for congested and/or complex aerodromes (e.g. close parallel runways) since ground-based LIDAR at an aerodrome can serve a dual purpose – i.e. wake vortices are an issue when wind shear is not.

## 2. Intended Performance Operational Improvement/Metric to determine success

<b>KPAs</b>	Specific improvement provided.
<i>KPA-02: Capacity</i>	Optimized usage of airspace capacity, thus achieving arrival and departure rates.  Metric: <a href="#">ACC</a> and aerodrome throughput.
<i>KPA-03: Cost effectiveness</i>	Reduction in costs through reduced arrival and departure delays (viz. reduced fuel burn).  Metric: Fuel consumption and associated costs.
<i>KPA-04: Efficiency</i>	Harmonized arriving air traffic (en-route to terminal area to aerodrome) and harmonized departing air traffic (aerodrome to terminal area to en-route) will translate to reduced arrival and departure holding times and thus reduced fuel burn.  Metric: Fuel consumption and flight time punctuality.
<i>KPA-05: Environment</i>	Reduced fuel burn through optimized departure and arrival profiling/scheduling.  Metric: Fuel burn and emissions.
<i>KPA-06: Flexibility</i>	Supports pre-tactical and tactical arrival and departure sequencing and thus dynamic air traffic scheduling.  Metric: <a href="#">ACC</a> and aerodrome throughput.
<i>KPA-07: Global interoperability</i>	Gate-to-gate seamless operations through common access to, and use of, the available WAFS, IAVW and tropical cyclone watch forecast information.  Metric: <a href="#">ACC</a> throughput.
<i>KPA-08: Participation by the ATM community</i>	Common understanding of operational constraints, capabilities and needs, based on expected (forecast) meteorological conditions.  Metric: Collaborative decision making at the aerodrome and during all phases of flight.
<i>KPA-09: Predictability</i>	Decreased variance between the predicted and actual air traffic schedule.

	Metric: Block time variability, flight-time error/buffer built into schedules.
<i>KPA-10: Safety</i>	Increased situational awareness and improved consistent and collaborative decision making. Metric: Incident occurrences.

<a href="#"><u>CBA</u></a>	To be developed]
----------------------------	------------------

### 3. Necessary Procedures (Air & Ground)

Description of new procedures. Where procedures exist or are under development, references to these must be provided. For procedures to be developed, the requirement must be clearly stated (This is applicable to latter blocks).

No new procedures necessary.

ICAO Annex 3 – *Meteorological Service for International Air Navigation* provides the internationally agreed requirements pertaining to, *inter alia*, the WAFS, the IAVW, the tropical cyclone watch, and aerodrome warnings, wind shear warnings and alerts.

Supporting guidance material is contained in a number of ICAO manuals, including but not limited to: *Manual of Aeronautical Meteorological Practice* (Doc 8896); *Manual on Coordination between Air Traffic Services, Aeronautical Information Services and Aeronautical Meteorological Services* (Doc 9377); *Handbook on the International Airways Volcano Watch – Operational Procedures and Contact List* (Doc 9766); and *Manual on Low Level Wind Shear* (Doc 9817). In addition, the *Manual on volcanic ash, radioactive material and toxic chemical clouds* (Doc 9691) provides extensive guidance on, *inter alia*, the observation/detection and forecasting of volcanic ash in the atmosphere and the effect of volcanic ash on aircraft.

ICAO Regional Air Navigation Plans contain region-specific requirements pertaining to WAFS, IAVW and tropical cyclone watch information and exchange.

### 4. Necessary System Capability

#### 4.1 Avionics

Description of required avionics. Where avionics exist or are under development, references to these must be *provided*. For avionics to be developed, the requirement must be clearly stated (This is applicable to latter blocks).

No new or additional avionics requirements and brought about by this module.

#### 4.2 Ground Systems

ANSPs, Airport operators and Airspace users may want to implement functionalities allowing them to display in plain text the different messages provided by the different Met organisations. For Block 0 airspace users may use their [AOC](#) data link connection to the aircraft to send the information where appropriate.

## 5. Human Performance

### 5.1 Human Factors Considerations

#### 5.1.1 General statements on the impact on operational functions

This module will not necessitate significant changes in how air navigation service providers and users access and make use of the available meteorological information today.

### 5.2 Training and Qualification Requirements

Description of required training and qualification requirements: Where they exist or are under development, references to these must be provided. For training and qualification requirements to be developed, the requirement must be clearly stated (This is applicable to latter blocks).

No new or additional training and qualification requirements are brought about by this module.

### 5.3 Others

None.

## 6. Regulatory/standardization needs and Approval Plan (Air and Ground)

No new or additional regulatory/standardization needs and approval plan(s) are brought about by this module. Provisions relating to the WAFS, the IAVW and the tropical cyclone watch, as well as aerodrome warnings, wind shear warnings and alerts, already exist within ICAO Annex 3, regional air navigation plans, and supporting guidance.

## 7. Implementation and Demonstration Activities

### 7.1 Current Use

Description and results of current demonstration activities and implementation status, for each known region

The elements of this module are in current use.

Elements 1 to 3:

Information made available by the WAFCs, VAACs and TCACs within the framework of the WAFS, IAVW and the tropical cyclone watch respectively is available via the ICAO AFS and public Internet as follows:

- i) the Satellite Distribution System for Information Relating to Air Navigation (SADIS) Second Generation (2G) satellite broadcast;
- ii) the International Satellite Communications Systems (ISCS) Third generation (G3) satellite broadcasts. [Note: ISCS G3 service will be withdrawn by the United States as the ISCS provider State on 1 July 2012];
- iii) the Secure SADIS File Transfer Protocol (FTP) service; and
- iv) the World Area Forecast System Internet File Service (WIFS).

The United Kingdom, as the SADIS provider State, provides (i) and (iii) for authorized users in the ICAO EUR, MID, AFI Regions and Western part of the ASIA Region; whilst the United States, as the ISCS/WIFS provider State, provides (ii) and (iv) for authorized users in the rest of the world.

Authorized access to the SADIS/SADIS FTP and ISCS/WIFS services is determined by the Meteorological Authority of the State concerned in consultation with the users.

In addition to the above, volcanic ash and tropical cyclone advisory information in alphanumeric form is available on the ICAO Aeronautical Fixed Telecommunication Network (AFTN).

Elements 4 and 5:

Aerodrome warnings are in current use at all aerodromes worldwide (except where a State difference is filed).

Wind shear detection and alerting systems are in current use at many aerodromes worldwide where wind shear is considered a factor – for example, Funchal airport in Maderia (Portugal), Hong Kong international airport (Hong Kong, China) and numerous aerodromes in the United States.

At the new Hong Kong International Airport (HKIA), which opened in July 1998, anemometers were installed at hilltops, valleys, outlying islands and weather buoys around the airport for the provision of wind shear warning services. An algorithm called Anemometer-based Windshear Alerting Rules — Enhanced (AWARE) using data from these anemometers was developed to generate wind shear alerts automatically, mainly for covering shear associated with sea breeze and low-level shear lines.

## **7.2 Planned or Ongoing Activities**

Description of planned demonstration and implementation activities, for each known region

Enhancement to the international provisions governing the meteorological information provided by the designated Centres within the frameworks of the WAFS, the IAVW and the tropical cyclone watch, and to aerodromes warnings, wind shear warnings and alerts, undergo periodic review and, where required, amendment, in accordance with standard ICAO procedure.

## **8. Reference Documents**

This section shall contain details of all known reference documents both published and in preparation.

### **8.1 Standards**

- ICAO and Industry Standards (ie; MOPS, [MASPS](#), SPRs).
- ICAO and World Meteorological Organization (WMO) international standards for meteorological information (including, content, format, quantity, quality, timeliness and availability).

### **8.2 Procedures**

Documented procedures by States and ANSPs. [To be developed]

### **8.3 Guidance Material**

- ICAO Manuals, Guidance Material and Circulars. Also any similar industry documents
- ICAO Doc 7192, Training Manual - Part F1 – *Meteorology for Air Traffic Controllers and Pilots*;
- ICAO Doc 8896, *Manual of Aeronautical Meteorological Practice*;
- ICAO Doc 9161, *Manual on Air Navigation Services Economics*;
- ICAO Doc 9377, *Manual on Coordination between Air Traffic Services, Aeronautical Information Services and Aeronautical Meteorological Services*;
- ICAO Doc 9691, *Manual on Volcanic Ash, Radioactive Material and Toxic Chemical Clouds*;
- ICAO Doc 9766, – *Handbook on the International Airways Volcano Watch – Operational Procedures and Contact List*;
- ICAO Doc 9817, *Manual on Low Level Wind Shear*;
- ICAO Doc 9855, *Guidelines on the Use of the Public Internet for Aeronautical Applications*
- *SADIS User Guide*;
- Agreement on the Sharing of Costs of the Satellite Distribution System for Information relating to Air Navigation.

### **8.4 Approval Documents.**

## Module N° B1-105: Enhanced Operational Decisions through Integrated Meteorological Information (Planning and Near-term Service)

<b>Summary</b>	This module enables the reliable identification of solutions when forecast or observed meteorological conditions impact aerodromes or airspace. Full ATM-Meteorology integration is needed to ensure that; meteorological information is included in the logic of a decision process and the impact of the meteorological conditions (the constraints) are automatically calculated and taken into account. The decision time-horizons range from several minutes to several hours ahead of the ATM operation (this includes optimum flight profile planning and tactical in-flight avoidance of hazardous meteorological conditions).	
<b>Main Performance Impact</b>	KPA-02 Capacity; KPA-04 Efficiency; KPA-05 Environment KPA-06 Flexibility, KPA-09 Predictability, KPA-10 Safety	
<b>Operating Environment/Phases of Flight</b>	All flight phases	
<b>Applicability Considerations</b>	Applicable to traffic flow planning, and to all aircraft operations in all domains and flight phases, regardless of level of aircraft equipage.	
<b>Global Concept Component(s)</b>	AOM - Airspace Operations and Management DCB - Demand and Capacity Balancing AO - Aerodrome Operations	
<b>Global Plan Initiatives (GPI)</b>	GPI-19 Meteorological Systems GPI-6 Air Traffic Flow Management GPI-16 Decision Support Systems and Alerting Systems	
<b>Pre-Requisites</b>	Module B0-10: Improved En-Route Profiles, Module B0-15: Runway Arrival Sequencing; Module B0-35: Air Traffic Flow Management/Network Operations Procedures ( <a href="#">ATFM/NOP</a> ) and Collaborative Decision Making (CDM); Parallel development with; Module B1-15 Arrival Management/Departure Management (AMAN/DMAN) Metroplex and Linked DMAN/Surface Management (SMAN); Module B1-35: Enhanced NOP, Integrated Airspace/Flow Management	
<b>Global Readiness Checklist</b>		<b>Status (ready now or estimated date).</b>
	Standards Readiness	Est 2018
	Avionics Availability	2018
	Infrastructure Availability	Est 2018
	Ground Automation Availability	Est 2018
	Procedures Available	Est 2018
	Operations Approvals	Est 2018

### 1. Narrative

#### 1.1 General

This module improves the current baseline case where ATM decision makers manually determine the amount of change in capacity associated with an observed or forecast meteorological condition (for example, thunderstorm activity), manually compare the resultant capacity with the actual or projected demand for the airspace or aerodrome, and then manually devise ATM solutions when the demand exceeds the meteorologically-constrained capacity value. This module also improves in-flight avoidance of hazardous meteorological conditions by providing more precise information on the location, extent, duration and severity of the hazard(s) affecting specific flights.



This module is a key component in the evolution of procedures and automation capabilities, both aircraft-based and ground-based, intended to mitigate the effects of hazardous meteorological conditions on flight planning, flight operations and flow management, whilst also enabling such users to make optimum use of meteorological conditions that are not hazardous to flight.

### **1.1.1 Baseline**

Meteorological conditions hazardous to flight are a major cause of flight delay in many airspace systems. Research analyses have suggested that a significant portion of this delay could be mitigated if meteorological forecasts were “perfect” (i.e. eradication of forecast uncertainty) and appropriate air traffic management (ATM) solutions could be consistently devised and employed. Rigid airspace structures often preclude the consistent employment of the best ATM solutions. However, such is the nature of earth’s atmosphere that forecast uncertainty could never be eradicated completely, particularly over extended time horizons. Therefore, there is a desire to reduce forecast uncertainty to the maximum extent possible (viz. maximum level of confidence) for given meteorological conditions.

ATM-Meteorology Integration (hereunder referred to as ATM-MET Integration) means that meteorological information is included in the logic of a decision process or aid such that the impact of the meteorological constraint is automatically calculated and taken into account when the decision is made or recommended. By minimizing the need for humans to manually assess meteorological constraints and determine the most appropriate mitigation of those constraints, ATM-MET Integration enables the best ATM solutions to be consistently identified and executed.

The concepts, capabilities and processes achieved in this module are applicable to multiple decision time frames, from pre-flight planning to daily flow planning to tactical flow planning. Initial improvements to tactical avoidance of hazardous meteorological conditions are also considered in this module, but utilization of advanced aircraft-based capabilities in this regard are emphasized in module B3-105.

### **1.1.2 Change brought by the module**

The transition to systems and processes embodied by ATM-MET Integration leads to the consistent identification and use of operationally effective ATM solutions to meteorologically-related demand/capacity imbalances, and tactical avoidance of hazardous meteorological conditions.

There are four elements of ATM-MET Integration as enabled by this module. With respect to airspace, the output of the first element, *Meteorological Information*, is ingested by automation associated with the second, *Meteorological Information Translation*. Through filters such as safety regulations and standard operating procedures, the meteorological information (observations and forecasts) is turned (“translated”) into a non-meteorological parameter called an airspace constraint, a measure of the expected capacity of the affected airspace. This parameter is, in turn, fed to the third component called *ATM Impact Conversion*. By comparing projected demand and meteorologically-constrained capacity, this component transforms (“converts”) the airspace constraint into an airspace impact. The fourth component, *ATM Decision Support*, takes the quantified impact values from *ATM Impact Conversion* and develops one or more strategic and tactical ATM solutions to the observed or forecast meteorological constraint.

## **1.2 Element 1: Meteorological Information**

Meteorological Information is the superset of all required aeronautical meteorological observations and forecasts available to operator and air navigation service provider (ANSP) decision makers. Included in this superset are data designated as the authoritative meteorological information based upon which ATM decision makers will build their solutions.

## **1.3 Element 2: Meteorological Information Translation**

Meteorological Information Translation refers to automated processes that ingest raw aeronautical meteorological information and translate them into characterized meteorological constraints and airspace or aerodrome threshold events. The output of the Meteorological Information Translation process is a non-meteorological value that represents a potential change in the permeability of airspace or capacity of the aerodrome.

It is unlikely that future automation systems will incorporate Meteorological Information Translation methodology without also including ATM Impact Conversion components. As such, this element is likely to be more of an enabler of the next element and the entire process rather than an interim end state.

**1.4 Element 3: ATM Impact Conversion**

The ATM Impact Conversion element determines the anticipated meteorologically-constrained capacity of the airspace or aerodrome and compares this to the projected demand. If an imbalance exists between the two, this information is provided to the system user and/or the ATM Decision Support element to inform development of mitigation strategies for dealing with the imbalance.

**1.5 Element 4: Meteorological Information Integrated Decision Support**

The final element is Meteorological Information Integrated Decision Support, comprised of automated systems and processes that create ranked mitigation strategies for consideration and execution by ATM decision makers. The solutions are based on requirements and rules established by the ATM community. These improvements also augment the communication and display of meteorological information to service providers and operators to support tactical avoidance.

**2. Intended Performance or Operational Improvement / Metric for Success**

<p><i>Capacity</i></p>	<p>Improvements in the content, format, quantity, quality, timeliness and availability of meteorological information (observations and forecasts) will lead to enhanced situational awareness of meteorological conditions, and in particular the location, extent, duration and severity of hazardous meteorological conditions and their impacts on airspace. This in turn enables more precise estimates of expected capacity of that airspace. <u>Associated Metric:</u> Improved meteorological information in reference to the number of user-preferred profiles that can be accommodated.</p> <p>Maximum use of available airspace capacity. <u>Associated Metric:</u> With respect to capacity, the number of user-preferred profiles that can be accommodated would be an appropriate metric for Meteorological Information Integrated Decision Support.</p>
<p><i>Efficiency</i></p>	<p>Improvements in the content, format, quantity, quality, timeliness and availability of meteorological information (observations and forecasts) will lead to enhanced situational awareness of meteorological conditions, and in particular the location, extent, duration and severity of hazardous meteorological conditions and their impacts on airspace. <u>Associated Metric:</u> An improvement in efficiency associated with improved meteorological information would be the number of deviations from user-preferred flight profiles.</p> <p>Advanced decision support tools, fully integrated with meteorological information, support stakeholders in planning for the most efficient routes possible, given the forecast meteorological conditions. <u>Associated Metric:</u> Among the measures of success for Meteorological Information Integrated Decision Support in the area of efficiency would be the number of deviations from user-preferred flight profiles.</p>
<p><i>Environment</i></p>	<p>More precise planning for mitigation of hazardous meteorological conditions produces safer, more efficient routes, less fuel burn, and reduction of emissions due to fewer ground hold/delay actions. <u>Associated Metric:</u> Fewer reroutes and less variability in associated traffic management initiatives (TMIs) can be expected.</p>
<p><i>Flexibility</i></p>	<p>Users have greater flexibility in selecting trajectories that best meet their needs, taking into account the observed and forecast meteorological conditions. <u>Associated Metric:</u> Fewer reroutes and less variability in associated traffic management initiatives (TMIs) can be expected.</p>

<p><i>Predictability</i></p>	<p>Meteorological Information Translation combined with ATM Impact Conversion leads to more consistent evaluations of meteorological constraints, which in turn will allow users to plan trajectories that are more likely to be acceptable from the standpoint of the <a href="#">ANSP</a>. <u>Associated Metric:</u> Fewer reroutes and less variability in associated traffic management initiatives (TMIs) can be expected. Consequently, airspace users will be able to carry less contingency fuel than is felt necessary today, resulting in lower fuel burn.</p> <p>Fewer reroutes and less variability in associated traffic management initiatives (TMIs) can be expected. Consequently, airspace users will be able to carry less contingency fuel than is felt necessary today, resulting in lower fuel burn. <u>Associated Metric:</u> Among the measures of success for both Meteorological Information Translation and ATM Impact Conversion are decreases in the variability and numbers of responses to a given meteorological conditions, along with reduced contingency fuel carriage for the same meteorological situation.</p> <p>Advanced decision support tools, fully integrated with meteorological information, produce consistent, optimal solution sets, and allow users to plan trajectories that are more likely to be acceptable from the standpoint of the ANSP. Fewer reroutes and less variability in other associated traffic management initiatives (TMIs) can be expected. In turn, this will allow airspace users to carry less contingency fuel than is felt necessary today, resulting in lower fuel burn. <u>Associated Metric:</u> Decreases in the variability and numbers of ATM responses to a given meteorological situation, along with reduced contingency fuel carriage for the same meteorological situation.</p>
<p><i>Safety</i></p>	<p>Meteorological information improvements lead to increased situational awareness by pilots, AOCs and ANSPs, including enhanced safety through the avoidance of hazardous meteorological conditions. <u>Associated Metric:</u> Safety improvement associated with enhanced (quantity, quality and availability of) meteorological information would be the number of meteorologically-related aircraft incidents and accidents.</p> <p>Advanced decision support tools, fully integrated with meteorological information, produce solution sets that minimize pilot exposure to hazardous meteorological conditions. This, combined with increased situational awareness of observed and forecast meteorological conditions by pilots and ANSPs, enables avoidance of hazardous conditions. <u>Associated Metric:</u> Decreases in the variability and numbers of responses to a given meteorological condition, along with reduced contingency fuel carriage for the same meteorological condition.</p>
<p><a href="#">CBA</a></p>	<p>The business case for this element is still to be determined as part of the development of this overall module, which is in the research phase. Current experience with utilization of ATM decision support tools, with basic meteorological input parameters to improve ATM decision making by stakeholders has proven to be positive in terms of producing consistent responses from both the ANSP and user community.</p>

### 3. Necessary Procedures (Air & Ground)

Procedures exist today for ANSPs and users to collaborate on meteorologically-related decisions. Extension to these procedures must be developed to reflect the increased use of decision support automation capabilities by both. International standards for information exchange between systems to support global operations must be developed, including the enhancement of existing global standards concerning the transmission/reception of meteorological information to/by the end user.

## **4. Necessary System Capability**

### **4.1 Avionics**

This module does not depend on significant additional avionics. Improved meteorological information can be disseminated to the pilot via flight operations centres, controllers, or via air-ground links (e.g. FIS) where available. The extensive use of aircraft-based capabilities to support tactical avoidance of hazardous meteorological conditions is the focus of module B3-105.

### **4.2 Ground Systems**

Technology development in support of this element will include the creation and implementation of a consistent, integrated four-dimensional (4-D) database of global meteorological information (observations and forecasts), including linkage (through information exchange and communications standards) between global, regional or sub-regional meteorological information systems.

Technology development in support of this element will include the introduction of:

- a) automated meteorological information translation methodologies based on the operational needs for such information:
- b) automated methodologies that use meteorological information translation data to assess the impact on ATM operations, for flows and individual flights: and
- c) decision support tools, for both ANSPs and users, which automatically ingest ATM Impact Conversion information, and support decision making via generation of candidate mitigation strategies.

## **5. Human Performance**

### **5.1 Human Factors Considerations**

This module will necessitate significant changes in how service providers and users deal with meteorological conditions. The availability of decision support tools, integrated with enhanced observation and forecast meteorological information, will enable more efficient and effective development of mitigation strategies. But, procedures will need to be developed, and changes to cultural aspects of how decision making is done today will need to be considered. Also, the realization of a “common view” of meteorological conditions between service providers, flight operations and pilots will require trust in a single, common set (a single authoritative source) of meteorological information.

### **5.2 Training and Qualification Requirements**

Automation support, integrated with meteorological information is needed for flight operations, pilots and service providers. Training in the concepts behind the automation capabilities will be necessary to enable the effective integration of decision support tools into operations. Also, enhanced procedures for collaboration on ATM decision-making will need to be developed and training provided, again to ensure effective operational use.

## **6. Regulatory/Standardization needs and Approval Plan (Air & Ground)**

This module requires the development of global standards for meteorological information exchange, with emphasis on the exchange of 4-D (latitudinal, longitudinal, vertical and temporal) digitized meteorological information, and regulatory agreement on what constitutes required meteorological information in the digital information exchange era versus traditional gridded, binary, alphanumeric and graphic formats. Standardized Meteorological Information Translation parameters and ATM Impact Conversion parameters will also require development.

## **7. Implementation and Demonstration Activities**

### **7.1 Current Use**

A considerable amount of research and analysis is currently underway. The development of the United States' 4-D Weather Data Cube is underway. Decisions concerning internal infrastructure, data exchange standards and communications are nearing completion, and initial demonstrations of the system have taken place.

### **7.2 *Planned or Ongoing Activities***

No global demonstration trials are currently planned for this element. There is a need to develop such an activity as part of the collaboration on this module.

## **8. Reference Documents**

### **8.1 *Standards***

ICAO and World Meteorological Organization (WMO) international standards for meteorological information (including, content, format, quantity, quality, timeliness and availability).

Others TBD; to be developed as part of this research

### **8.2 *Procedures***

To be developed

### **8.3 *Guidance material***

To be developed.

### **8.4 *Approval Documents***

This Page Intentionally Left Blank

## Module N° B3-105: Enhanced Operational Decisions through Integrated Meteorological Information (Near-term and Immediate Service)

<b>Summary</b>	The aim of this module is to enhance global ATM decision making in the face of adverse meteorological conditions. This module builds upon the initial information integration concept and capabilities developed under B1-105. Key points are a) tactical avoidance of hazardous meteorological conditions in the 0-20 minute timeframe, b) greater use of aircraft based capabilities to detect meteorological parameters (e.g. turbulence, winds, and humidity), and c) display of meteorological information to enhance situational awareness. This module also promotes the establishment of standards for the global exchange of the information.	
<b>Main Performance Impact</b>	KPA-02 Capacity; KPA-04 Efficiency; KPA-09 Predictability, KPA-10 Safety	
<b>Operating Environment/Phase of Flight</b>	All	
<b>Applicability Considerations</b>	Applicable to air traffic flow planning, en-route operations, terminal operations (arrival/departure), and surface. Aircraft equipage is assumed in the areas of <a href="#">ADS-B In/CDTI</a> , aircraft-based meteorological observations, and meteorological information display capabilities, such as EFBs.	
<b>Global Concept Component(s)</b>	AOM- Airport Operations and Management DCB -Demand and Capacity Balancing AO -Aerodrome Operations TM-Traffic Synchronization CM -Conflict Management	
<b>Global Plan Initiatives (GPI)</b>	GPI-9: Situational Awareness GPI-15: Match IMC and VMC Operating Capacity GPI-19: Meteorological Systems	
<b>Pre-Requisites</b>	Successor to B1-105	
<b>Global Readiness Checklist</b>		<b>Status (ready now or estimated date)</b>
	Standards Readiness	Est 2023
	Avionics Availability	Est 2023
	Infrastructure Availability	<b>Est 2023</b>
	Ground Automation Availability	Est 2023
	Procedures Available	Est 2023
	Operations Approvals	Est 2023

### 1. Narrative

#### 1.1 General

This module is focused on developing advanced concepts and necessary technologies to enhance global ATM decision making in the face of hazardous meteorological conditions. The major components include a consistent, integrated set of meteorological information available to all users and ANSPs, advanced decision support tools that utilize the information to assess the potential operational impacts of the meteorological situation and decision support tools that develop candidate mitigation strategies for dealing with the impacts.

The capabilities discussed in this module will primarily benefit in-flight operations and avoidance of hazardous meteorological conditions in the en-route, terminal area and aerodrome domains. But, this module will also extend initial pre-flight and flow planning capabilities realized in module B1-105. These negotiation capabilities will be globally interoperable to allow for seamless planning of trajectories for international flights.

### **1.1.2 Baseline**

The baseline for this module is the initial, enhanced operational decision making capabilities enabled by module B1-105. Decision support capabilities are available, and integrated with meteorological information, to assist ANSPs and users to make better decisions in the strategic timeframe (40 minutes or more). A consistent, integrated meteorological information base is available to all ANSPs and users, to inform ATM decision making.

### **1.1.3 Change brought by the module**

This module provides extensions to this baseline, with emphasis on the tactical (0-420 minute) timeframe, and greater use of aircraft-based capabilities for meteorological awareness and avoidance. A major focus is on the provision of enhanced automation capabilities (building on B1-105) for developing characterizations of potential meteorologically-impacted airspace, and for using those characterizations to determine impact on ATM operations and individual flights.

#### **1.2 Element 1: Enhanced Meteorological Information**

This element is focused on the development of enhanced meteorological information for integration into ATM decision making. The scope of meteorological information to be considered includes observations and forecasts of the full range of aviation-relevant phenomena. This also includes an emphasis on increasing the availability of characterizations of potentially meteorologically-constrained airspace which may be directly integrated into [ANSP](#) and user decision making. This element also focuses on the development or revision of global standards for meteorological information content and format, given the migration to four-dimensional (4-D) representations of meteorological information, versus traditional gridded, binary, alphanumeric and graphic formats.

#### **1.3 Element 2: Meteorology-Integrated Decision Support Tools**

This element continues the evolution to the utilization of ATM decision support tools, used by ANSPs and users, which directly integrates meteorological information into their processing. Based on experiences gained from development and deployment of initial capabilities as part of module B1-105, extensions are developed to generate more efficient and operationally acceptable meteorologically-related mitigation solutions. This element also develops direct automation-to-automation negotiation capabilities (both ground-based and aircraft-based) to streamline the development of mutually acceptable ATM decisions.

#### **1.4 Element 3: Cockpit Meteorological Information Capabilities**

This element will focus on aircraft-based capabilities that will assist pilots with avoidance of hazardous meteorological conditions, and thus enhance safety. Capabilities such as [ADS-B In](#), air-to-air information exchange, and integration of meteorological information into cockpit-based automation tools are considered. In addition, increased availability of aircraft-based meteorological observations will further enhance situational awareness, and help to improve meteorological forecasting capabilities. This element must focus on globally-harmonized standards development for meteorological information exchange to support these capabilities.



## 2. Intended Performance Operational Improvement/Metric to determine success

<i>Capacity</i>	Better information on the location, extent, duration and severity of hazardous meteorological conditions on airspace enables more precise estimates of expected capacity of that airspace.  Advanced decision support tools, integrated with meteorological information, supports stakeholders in assessing the meteorological situation and in planning mitigation strategies, which make maximum use of available airspace.
<i>Efficiency</i>	Better information on the location, extent, duration and severity of hazardous meteorological conditions on airspace enables better utilization of available capacity and accommodation of user-preferred profiles.
<i>Safety</i>	Increased situational awareness by pilots and ANSPs enables avoidance of hazardous meteorological conditions.

<a href="#">CBA</a>	The business case is still to be determined as part of the development of this module, which is in the research phase.
---------------------	--

To assess the operational improvement by the introduction of cockpit meteorological information capabilities, States can use, as appropriate, a combination of the following metrics:

### 3. Necessary Procedures (Air & Ground)

The necessary procedures basically exist for ANSPs and users to collaborate on meteorologically-related decisions. Extensions to those procedures will be developed to reflect the use of enhanced meteorological observation and forecast information, plus the use of characterizations of potential meteorologically-impacted airspace. International standards for information exchange between systems to support these improved ATM operations must be developed. This includes development of global standards for the delivery of meteorological information to aircraft.

The use of [ADS-B/CDTI](#) and other cockpit capabilities to support avoidance of hazardous meteorological conditions by pilots will necessitate procedure development, including the roles of ANSPs. International standards for meteorological information exchange between ground-based and aircraft-based systems to support these operations must be developed. This includes development of global standards for the delivery of meteorological information to aircraft.

### 4. Necessary System Capability

#### 4.1 Avionics

This module has a significant dependency on advanced aircraft capabilities being widely available. Although aircraft-based capabilities such as ADS-B/CDTI and EFBs exist, the level of equipage is still evolving, and applications are still being developed to support the objectives of this module. Also, integration of advanced (e.g. post-processed) meteorological information into aircraft-based decision support tools will be needed. Increased levels of aircraft equipage with meteorological sensors (e.g. turbulence, humidity, wind) will be necessary to ensure tactical situational awareness of meteorological conditions for all aircraft in an area of interest.

#### 4.2 Ground Systems

For this longer-term module, the needed ground-system technology is still in development. Research is ongoing into decision support tools that ingest meteorological information directly, and support the automated development of candidate mitigation strategies. For example, conflict resolution tools will be integrated with meteorological information to ensure aircraft are not inadvertently routed into hazardous meteorological conditions. Work is also needed to ensure a globally harmonized, common set (a single authoritative source) of meteorological information that is available to all ANSPs and users for decision making. Also, integration of ground-based and aircraft-based automation capabilities, including exchange of digital meteorological information, is needed to support tactical avoidance of hazardous meteorological conditions.

## 5. Human Performance

### 5.1 Human Factors Considerations

This module may necessitate changes in how service providers and users deal tactically with observed and/or forecast meteorological conditions. While pilots will continue to be responsible for the safe operation of their aircraft in hazardous meteorological conditions, the roles and responsibilities of controllers (informed by conflict resolution tools) must also be considered, in order to achieve safe and efficient approaches to avoidance of hazardous meteorological conditions. Also, the realization of a “common view” of the meteorological situation between service providers, flight operations and pilots will require trust in a single, common set (a single authoritative source of) meteorological information.

### 5.2 Training and Qualification Requirements

Automation support, integrated with meteorological information is needed for flight operations, pilots and service providers. Training in the concepts behind the automation capabilities will be necessary to enable the effective integration of the tools into operations. Also, enhanced procedures for collaboration on tactical avoidance of hazardous meteorological conditions will need to be developed and training provided, again to ensure effective operational use.

## 6. Regulatory/Standardization needs and Approval Plan (Air & Ground)

### 6.1 This module requires the following:

- Development of global standards for meteorological information exchange, with emphasis on exchange of 4-D (latitudinal, longitudinal, vertical, and temporal) digitized meteorological information.
- Regulatory agreement on what constitutes required meteorological information in the digital information exchange versus traditional gridded, binary, alphanumeric and graphic formats.
- Certification decisions on aircraft-based meteorological information display and dissemination. Dissemination includes air-to-ground for aircraft-based observations (e.g. turbulence and humidity), as well as possible air-to-air exchange of those observations (e.g. turbulence information to nearby aircraft) via [ADS-B](#).

## 7. Implementation and Demonstration Activities

### 7.1 Current Use

Many States and users have been utilizing a Collaborative Decision Making (CDM) process for developing coordinated strategies for dealing with adverse meteorological conditions. These efforts have included the application of enhanced meteorological observation and forecast information, as it has developed. The United States Federal Aviation Administration (FAA) and the United States National Weather Service (NWS) are, for example, continuing research on aviation-related weather forecasts, at all decision time horizons. Initial demonstrations of these candidate products are showing promise in enhancing the quality and quantity of meteorological information upon which ATM decisions can be made, by ANSPs and users.

Since this module is in the category of Long Term Issues, there are limited examples of current operational use. In the United States, experience with the use of FIS-B and the Alaska Capstone effort have shown a significant safety benefit, with increased cockpit meteorological information display capabilities. Also, for General Aviation aircraft, private vendors are making meteorological information available in the cockpit, as optional services. The FAA is conducting research on [ADS-B](#) In applications that relate to avoidance of hazardous meteorological conditions via cockpit functionality. In Europe, FIS-B-like capabilities are being deployed currently in Sweden and Russia that provide for enhanced meteorological information available to pilots. (Suggest ICAO amplify on this addition, as appropriate) Such United States and European research efforts will help to inform the work necessary under this module.

### 7.2 Planned or Ongoing Activities

No global demonstration trials are currently planned for this module. There is a need to develop such a plan as part of the collaboration process, and as an extension of other modules.

## **8. Reference Documents**

### **8.1 Standards**

- ICAO and World Meteorological Organization (WMO) international standards for meteorological information (including content, format, quantity, quality, timeliness and availability).
- Others TBD; to be developed as part of this research.

### **8.2 Procedures**

To be developed

### **8.3 Guidance material**

### **8.4 Approval documents**

## **Performance Improvement Area 3: Optimum Capacity and Flexible Flights – Through Global Collaborative ATM.**

***Thread: Free-Routing***

This Page Intentionally Left Blank

## Module N° B0-10: Improved Operations through Enhanced En-Route Trajectories

<b>Summary</b>	To allow the use of airspace which would otherwise be segregated (i.e. military airspace) along with flexible routing adjusted for specific traffic patterns. This will allow greater routing possibilities, reducing potential congestion on trunk routes and busy crossing points, resulting in reduced flight length and fuel burn.	
<b>Main Performance Impact</b>	KPA-01 Access & Equity; KPA-02 Capacity; KPA-04 Efficiency; KPA-05 Environment; KPA-06 Flexibility; KPA-09 Predictability	
<b>Operating Environment/Phases of Flight</b>	En-route, TMA	
<b>Applicability Considerations</b>	Applicable to en-route airspace. Benefits can start locally. The larger the size of the concerned airspace the greater the benefits, in particular for flex track aspects. Benefits accrue to individual flights and flows.  Application will naturally span over a long period as traffic develops. Its features can be introduced starting with the simplest ones.	
<b>Global Concept Component(s)</b>	AOM – Airspace Organisation & Management AUO – Airspace Users Operations DCB – Demand-Capacity Balancing	
<b>Global Plan Initiatives (GPI)</b>	GPI-1 Flexible use of airspace GPI-4 Align upper airspace classifications GPI-7 Dynamic and Flexible Airspace Route Management GPI-8 Collaborative airspace design and management	
<b>Pre-Requisites</b>	NIL	
<b>Global Readiness Checklist</b>		<b>Status</b> (ready now or estimated date)
	Standards Readiness	✓
	Avionics Availability	✓
	Ground Systems Availability	✓
	Procedures Available	✓
	Operations Approvals	✓

### 1. Narrative

#### 1.1 General

In many areas, flight routings offered by air traffic control (ATC) services are static and are slow to keep pace with the rapid changes of users operational demands, especially for long-haul city-pairs. In certain parts of the world, legacy regional route structures have become outdated and are becoming constraining factors due to their inflexibility.

The navigational capabilities of modern aircraft make a compelling argument to migrate away from the fixed route structure towards a more flexible alternative. Constantly changing upper winds have a direct influence on fuel burn and, proportionately, on the carbon footprint. Therein lies the benefit of daily flexible routings. Sophisticated flight planning systems in use at airlines now have the capability to predict and validate optimum daily routings. Likewise, ground systems used by ATC have significantly improved their communication, surveillance and flight data management capabilities.

Using what is already available on the aircraft and within ATC ground systems, the move from Fixed to Flex routes can be accomplished in a progressive, orderly and efficient manner.

### 1.1.1 Baseline

The baseline for this module is varying from a State/region to the next. However, while some aspects have already been the subject of local improvements, the baseline generally corresponds to an airspace organisation and management function which is at least in part characterized by: individual State action, fixed route network, permanently segregated areas, conventional navigation or limited use of RNAV, rigid allocation of airspace between civil and military authorities. Where it is the case, the integration of civil and military [ATC](#) has been a way to eliminate some of the issues, but not all.

### 1.1.2 Change brought by the module

This module is aimed at improving the profiles of flights in the en-route phase through the deployment and full application of procedures and functionalities on which solid experience is already available, but which have not been always systematically exploited and which are of a nature to make a better use of the airspace.

The module is the opportunity to exploit PBN capabilities in order to eliminate design constraints and operate more flexibly, while facilitating the overall handling of traffic flows.

The module is made of the following elements:

- Airspace Planning: possibility to plan, coordinate and inform on the use of airspace. This includes CDM applications for En-Route Airspace to anticipate on the knowledge of the airspace use requests, take into account preferences and inform on constraints.
- FUA: flexible use of airspace to allow both the use of airspace otherwise segregated, and the reservation of suitable volumes for military usage; this includes the definition of conditional routes.
- Flexible routing (Flex Tracking): route configurations designed for specific traffic pattern.

This module is a first step towards more optimized organisation and management of the airspace but which would require more sophisticated assistance. Initial implementation of PBN, RNAV for example, takes advantage of existing ground technology and avionics and allows extended collaboration of ANSPs with partners: military, airspace users, neighbouring States.

## 1.2 Element 1: Airspace Planning

Airspace planning entails activities to organise and manage airspace prior to the time of flight. Here it is more specifically referred to activities to improve the strategic design by a series of measures to better know the anticipated use of the airspace and adjust the strategic design by pre-tactical or tactical actions.

## 1.3 Element 2: FUA

Flexible use of airspace is an airspace management concept, according to which airspace should not be designated as either purely civil or purely military airspace, but should rather be considered as one continuum in which all users' requirements have to be accommodated to the maximum extent possible. There are activities which require the reservation of a volume of airspace for their exclusive or specific use for determined periods, owing to the characteristics of their flight profile or their hazardous attributes and the need to ensure effective and safe separation from non participating air traffic. Effective and harmonized application of FUA needs clear and consistent rules for civil-military coordination which should take into account all users' requirements and the nature of their various activities. Efficient civil-military coordination procedures should rely on rules and standards to ensure efficient use of airspace by all users. It is essential to further cooperation between neighbouring States and to take into account cross border operations when applying the concept of FUA.

Where various aviation activities occur in the same airspace but meet different requirements, their coordination should seek both the safe conduct of flights and the optimum use of available airspace.

Accuracy of information on airspace status and on specific air traffic situations and timely distribution of this information to civil and military controllers has a direct impact on the safety and efficiency of operations.

Timely access to up-to-date information on airspace status is essential for all parties wishing to take advantage of airspace structures made available when filing or re-filing their flight plans.

The regular assessment of airspace use is an important way of increasing confidence between civil and military service providers and users and is an essential tool for improving airspace design and airspace management.

[FUA](#) should be governed by the following principles:

(a) coordination between civil and military authorities should be organized at the strategic, pre-tactical and tactical levels of airspace management through the establishment of agreements and procedures in order to increase safety and airspace capacity, and to improve the efficiency and flexibility of aircraft operations;

(b) consistency between airspace management, air traffic flow management and air traffic services should be established and maintained at the three levels of airspace management in order to ensure, for the benefit of all users, efficiency in airspace planning, allocation and use;

(c) the airspace reservation for exclusive or specific use of categories of users should be of a temporary nature, applied only during limited periods of time-based on actual use and released as soon as the activity having caused its establishment ceases;

(d) States should develop cooperation for the efficient and consistent application of the concept of FUA across national borders and/or the boundaries of flight information regions, and should in particular address cross-border activities; this cooperation shall cover all relevant legal, operational and technical issues;

(e) air traffic services units and users should make the best use of the available airspace.

#### **1.4 Element 3: Flexible Routing**

Flexible routing is a design of routes (or tracks) designed to match the traffic pattern and other variable factors such as weather. The concept, used over the North-Atlantic since decades can be expanded to address seasonal or week end flows, accommodate special events, and in general better fit the weather conditions, by offering a set of routes which provide routings closer to the user preferences for the traffic flows under consideration.

When already in place, flex tracks systems can be improved in line with the new capabilities of ATM and aircraft, such as PBN and ADS.

A current application of the element is DARPS, Dynamic Air route Planning System, used in the Pacific Region with flexible tracks and reduced horizontal separation to 30 NM using RNP 4 and automatic dependent surveillance (ADS) and controller pilot data link communications (CPDLC).

Convective weather causes many delays in today's system due to the labor intensive voice exchanges of complex reroutes during the flight. New data communications automation will enable significantly faster and more efficient delivery of reroutes around convective weather. This operational improvement will expedite clearance delivery resulting in reduced delays and miles flown during convective weather.

## **2. Intended Performance Operational Improvement**

**Metrics to determine the success of the module are proposed in the *Manual on Global Performance of the Air Navigation System (Doc 9883)*.**

<i>Access and Equity</i>	Better access to airspace by a reduction of the permanently segregated volumes.
<i>Capacity</i>	The availability of a greater set of routing possibilities allows reducing potential congestion on trunk routes and at busy crossing points. The flexible use of airspace gives greater possibilities to separate flights horizontally. PBN helps to reduce route spacing and aircraft separations. This in turn allows reducing controller workload by flight.
<i>Efficiency</i>	The different elements concur to trajectories closer to the individual optimum by reducing constraints imposed by permanent design. In particular the module will reduce flight length and related fuel burn and emissions. The potential savings are a significant proportion of the ATM related inefficiencies. The module will reduce the number of flight diversions and cancellations. It will also better allow avoiding noise sensitive areas.
<i>Environment</i>	Fuel burn and emissions will be reduced; however, the area where



	emissions and contrails will be formed may be larger.
<i>Flexibility</i>	The various tactical functions allow reacting rapidly to changing conditions.
<i>Predictability</i>	Improved planning allows stakeholders to anticipate on expected situations and be better prepared.

<u><a href="#">CBA</a></u>	<p>Element 2: <a href="#">FUA</a></p> <p>As an example, over half of the UAE airspace is military. Currently, civil traffic is concentrated on the northern portion of the UAE.</p> <p>Opening up this airspace could potentially enable yearly savings in the order of:</p> <ul style="list-style-type: none"> <li>▪ 4.9 million litres of fuel</li> <li>▪ 581 flight hours.</li> </ul> <p>In the U.S. a study for NASA by Datta and Barington showed maximum savings of dynamic use of SUA of \$7.8M (1995 \$).</p> <p>Element 3: Flexible Routing.</p> <p>Early modelling of flexible routing suggests that airlines operating a 10-hour intercontinental flight can cut flight time by six minutes, reduce fuel burn by as much as 2% and save 3,000 kilograms of CO2 emissions. These improvements in efficiency directly help the industry in meeting its environmental targets.</p> <p>Some of the benefits that have accrued from Flex Route programs in sub-region flows include:</p> <ul style="list-style-type: none"> <li>▪ Reduced flight operating costs (1% to 2% of operating costs on long-haul flights)</li> <li>▪ Reduced fuel consumption (1% to 2% on long-haul flights)</li> <li>▪ More efficient use of airspace (access to airspace outside of fixed airway structure)</li> <li>▪ More dynamic flight planning (airlines able to leverage capability of sophisticated flight planning systems)</li> <li>▪ Reduced carbon footprint (reductions of over 3,000 kg of CO2 on long-haul flights)</li> <li>▪ Reduced controller workload (aircraft spaced over a wider area)</li> <li>▪ Increased passenger and cargo capacity for participating flights (approximately 10 extra passengers on long-haul flights)</li> </ul>
----------------------------	---

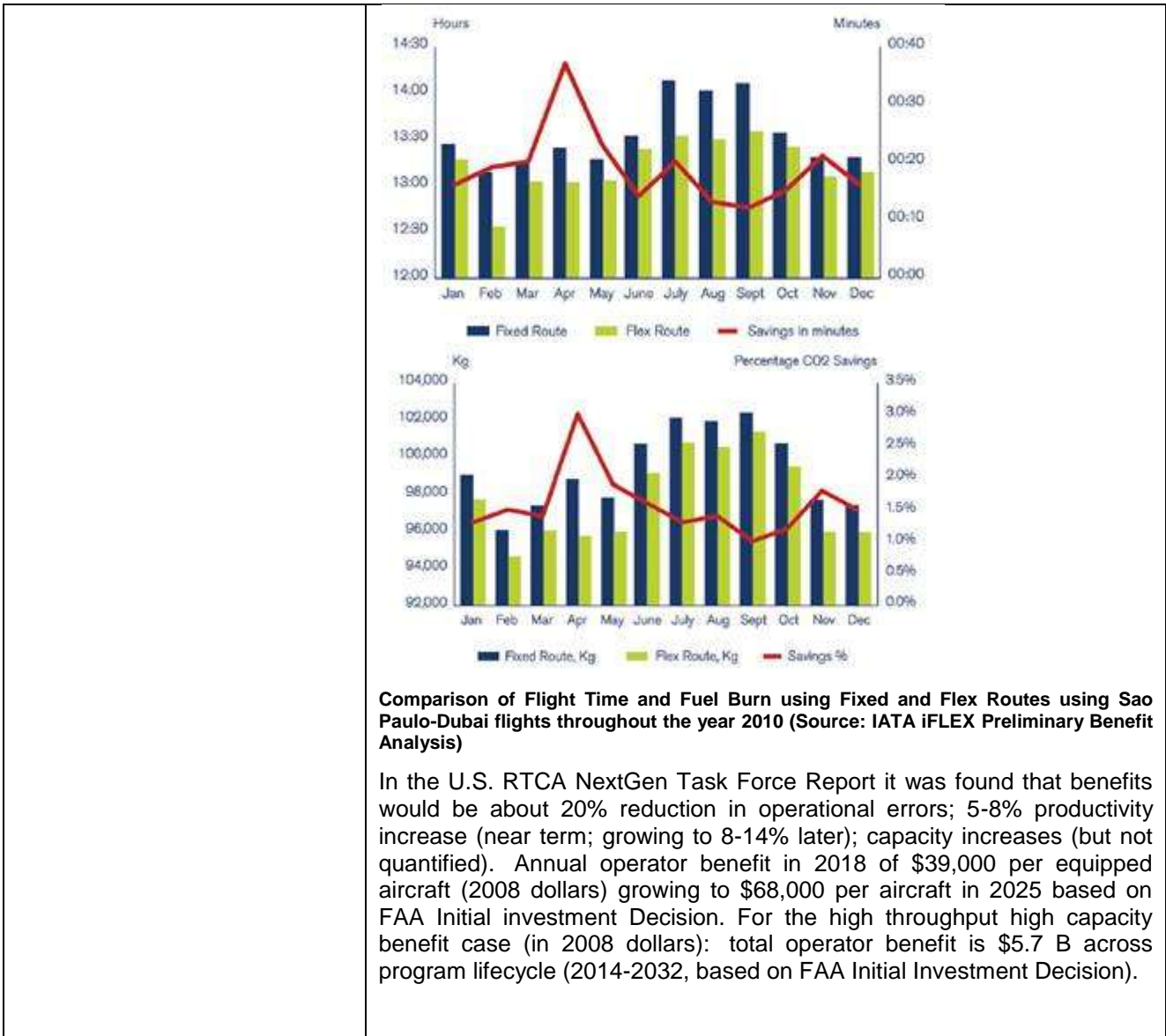

### 3. Necessary Procedures (Air & Ground)

Required procedures exist for the main. They may need to be complemented by local practical guidance and processes; however, the experience from other regions can be a useful reference source to be customised to the local conditions.

The development of new and/or revised ATM procedures is automatically covered by the definition and development of listed elements. However, given the interdependencies between some of the modules, care needs to be taken so that the development of the required ATM procedures provides for a consistent and seamless process across these modules.

The airspace requirements (RNAV, RNP and the value of the performance required) may require new ATS procedures and ground system functionalities. Some of the ATS procedures required for this module are linked with the processes of notification, coordination and transfer of control, supported by messages exchange (module B0-25).

#### 3.1 Element 1: Airspace Planning

See general remarks above.

### 3.2 **Element 2: [FUA](#)**

The ICAO Circular 330 AN/189 Civil/Military Cooperation in Air Traffic Management offers guidance and examples of successful practices of Civil and Military Cooperation. It realizes that successful cooperation requires collaboration that is based on communication, education, a shared relationship and trust.

### 3.3 **Element 3: Flexible Routing**

A number of operational issues and requirements will need to be addressed to enable harmonized deployment of Flex Route operations in a given area such as:

- Some adaptation of Letters of Agreement;
- Revised procedures to consider the possibility of transfer of control at other than published fixes;
- Use of lat/longs or bearing and distance from published fixes, as sector or [FIR](#) boundary crossing points;
- Review of controller manuals and current operating practices to determine what changes to existing practices will need to be developed to accommodate the different flows of traffic which would be introduced in a Flex Route environment;
- Specific communication and navigation requirements for participating aircraft will need to be identified;
- Developing procedures that will assist ATC in applying separation minima between flights on the fixed airway structure and Flex Routes both in the strategic and tactical phases;
- Procedures to cover the transition between the fixed network and the Flex Route airspace both horizontally and vertically. In some cases, a limited time application (e.g. during night) of Flex Route operations could be envisaged. This will require modification of ATM procedures to reflect the night traffic patterns and to enable the transition between night Flex Route operations and daytime fixed airway operations;
- Training package for ATC.

## 4. **Necessary System Capability**

### 4.1 **Avionics**

Deployment of PBN is ongoing. The benefits provided to flights can facilitate its dissemination, but it will remain linked to how aircraft can fly.

Dynamic re-routing can require aircraft connectivity (ACARS, ...) to its Flight Operating Centre for flight tracking and the up-load of new routes computed by the FOC [FPS](#), and possibly [FANS](#). A capability for the exchange of clearance with ATC,

### 4.2 **Ground Systems**

Technology is available. Even CDM can be supported by a form of internet portal. However, since aviation operations are global, standardization of the information and its presentation will be increasingly required (see thread 30 on SWIM).

Basic FUA concept can be implemented with the existing technology. Nevertheless for a more advanced use of conditional routes, a robust collaborative decision system will be required including function for the processing and display of Flexible or direct routes containing latitude/longitude in addition to published fixes. A coordination function is also needed and may need specific adaptations to support transfer of control over non published points.

Enhanced flight planning systems (FPS) today are predicated on the determination of the most efficient flight profile. The calculations of these profiles can be driven by cost, fuel, time, or even a combination of the factors. All airlines deploy FPS at different levels of sophistication and automation in order to assist flight dispatchers/planners to verify, calculate and file flight plans.

Additionally, the flight dispatcher would need to ensure the applicability of over-flight permissions for the over-flown countries. Regardless of the route calculated, due diligence must always be exercised by the airline in ensuring that NOTAMs and any restrictive flight conditions will always be checked and validated before a flight plan is filed. Further, most airlines are required to ensure a flight following or monitoring program to update the crews with any changes in the flight planning assumptions that might have changed since the first calculation was made.

## 5. Human Performance

### 5.1 Human Factors Considerations

**5.1.1** The roles and responsibilities of controller/pilot are not affected. However, Human Factors have been taken into consideration during the development of the processes and procedures associated with this module. Where automation is to be used, the Human-Machine interface has been considered from both a functional and ergonomic perspective (See Section 6 for examples). The possibility of latent failures however, continues to exist and vigilance is requested during all implementation actions. It is further requested that human factor issues, identified during implementation, be reported to the international community through ICAO as part of any safety reporting initiative.

### 5.2 Training and Qualification Requirements

**5.2.1** The required training is available and the change step is achievable from a human factors perspective. Training in the operational standards and procedures are required for this module and can be found in the links to the documents in Section 8 to this module. Likewise, the qualifications requirements are identified in the regulatory requirements in Section 6 which form an integral part to the implementation of this module.

## 6. Regulatory/standardisation needs and Approval Plan (Air & Ground)

- **Regulatory/Standardization:** Use current published requirements that includes the material give in Section 8.4.
- **Approval Plans:** To Be Determined, based upon regional applications. Possible regional mandates of PBN should be considered.

### 6.1 Element 1: Airspace Planning

See general remarks above.

### 6.2 Element 2: [FUA](#)

Until today, the Chicago Convention in its Article 3 expressly excludes the consideration of State aircraft from the scope of applicability.

Exemption policies for specific State aircraft operations and services are currently used as a method to cope with the discrepancy of civil and military aviation needs. Some States already realise that for State aircraft a solution lays in an optimum compatibility to civil aviation, although military requirements have to be met. (JAPAN)

ICAO provisions related to coordination between civil and military in support to the Flexible Use of Airspace can be found in several Annexes, PANS and Manuals.

Annex 11 — Air Traffic Services allows States to delegate responsibility for the provision of ATS to another State. However, States retain sovereignty over the airspace so delegated, as confirmed by their adherence to the Chicago Convention. This factor may require additional effort or coordination in relation to civil/military cooperation and an appropriate consideration in bilateral or multilateral agreements.

### 6.3 Element 3: Flexible Routing

LoA/LoCs: Letters of agreement (LoA) and/or letters of coordination (LoC) might be required to reflect the specificities of Flex Route operations. Local hand-off procedures, timings and frequency allocations must be clearly detailed. Allocation schemes are also useful in designing major unidirectional flows, such as the EUR-Caribbean flows.

### 6.4 Common Enabler: PBN Procedures

Within an airspace concept, PBN requirements will be affected by the communication, surveillance and ATM environments, the navaid infrastructure, and the functional and operational capabilities needed to meet the ATM application. PBN performance requirements also depend on what reversionary, non-RNAV means of navigation are available and what degree of redundancy is required to ensure adequate continuity of functions.

The selection of the PBN specification(s) for a specific area or type of operation has to be decided in consultation with the airspace users. Some areas need only a simple RNAV to maximize the benefits, while other areas such as nearby steep terrain or dense air traffic may require the most stringent RNP. (JAPAN)International public standards for PBN and RNP are still evolving. International PBN/RNP is not widespread. According to the ICAO/IATA Global PBN Task Force, International Air Traffic Management (ATM) and State flight standards rules and regulations lag behind airborne capability.

There is a need for worldwide harmonization of RNP requirements, standards, procedures and practices, and common Flight Management System functionality for predictable and repeatable RNP procedures, such as fixed radius transitions, radius-to-fix legs, Required Time of Arrival (RTA), parallel offset, VNAV, 4D control, [ADS-B](#), data link, etc.

A Safety Risk Management Document (SRMD) may be required for every new or amended procedure. That requirement will extend the time required to implement new procedures, especially [PBN](#)-based flight procedures.

## 7. Implementation and Demonstration Activities

### 7.1 Current Use

Most of the proposed elements have already been implemented in at least a region.

In particular, one will note the following realisations which can be taken as examples of how to achieve the module.

#### 7.1.1 Element 1: Airspace Planning

- **Europe:** Airspace planning is implemented in European States with Airspace Management cells, and at European scale through the Network Operations Plan (NOP) which provide advanced notice on the (de)-activation of segregated airspace and conditional routes.
- **LARA:** LARA (Local and Sub-Regional Airspace Management Support System) is an initiative aimed at improving performance-based Airspace Management (ASM).

LARA provides a software application to support ASM. It is focused on automation at local and regional levels for civil-military and military-military coordination. It is intended to provide a more efficient and transparent decision-making process between civil and military stakeholders for ATM performance enhancement. It will also provide information for civil-military coordination at network level to support the MILO function (Military Liaison - MILO - function at [CFMU](#)). The LARA application will support the following:

- airspace planning: to manage airspace bookings; to incorporate Air Traffic Flow and Capacity Management (ATFCM) data into the airspace planning process; to facilitate the analysis and creation of a national/regional Airspace Plan; to assess network scenario proposals and to facilitate coordination for decision-making on a national level.
- Airspace status: to provide real-time, airspace common situation awareness.
- Statistics: in collating airspace data and measuring airspace utilization through meaningful civil-military KPIs, LARA will archive the data for further analysis.

A demonstrator was developed and successfully tested in January 2008. In 2009 LARA first prototype and various incremental versions based on it were delivered. Support to a [FABEC](#) trial has been initiated.

#### 7.1.2 Element 2: FUA

FUA has been implemented in Europe in the 90s and regularly improved on an as-needed basis. It leans on the airspace planning features described above, and coordination mechanisms to address the tactical coordination actions.

[CDM](#) is implemented in the US NASCSC.

#### 7.1.3 Element 3: Flexible Routing

- **North-Atlantic:** Implemented with two daily sets of Organized Track Systems
- **Japan:** Coordination of Airspace Use: In the coordination of rerouting for avoidance of airspace capacity saturation or adverse weather conditions, [ATMC](#) and Airline Operators share and use "Rerouting List" of the flight routes between city pairs, which has been established and updated after making the necessary coordination with Airline Operators and ATC facilities. Using the Rerouting list

makes coordination simple and the coordination is effective to decrease the demand of the congesting airspace and to identify the variation of air traffic flow. The major Airline Operators are able to coordinate by ATM Workstations. ATMC coordinates usage of the areas for IFRs with the Military Liaison Officers, and then IFRs are able to fly through the areas under following ATC instructions. Also taking into account requirement which IFRs enter the area for avoiding adverse weather, ATMC is able to coordinate with Military Liaison Officers for using Military Training/Testing Areas temporarily.

- **IATA:** IATA in conjunction with Emirates Airlines and Delta Airlines proposes to conduct a proof of concept of Flex Route capability on the Dubai – Sao Paulo and Atlanta – Johannesburg city-pairs respectively. The goal of the proof of concept trial is to gather performance data, measure tangible results and identify areas where mitigation may be required to address operational, procedural, and technical issues. Dependent on the results of the proof of concept trial, an operational trial with broader participation may be initiated in the future. This will allow airlines and ANSPs to take advantage of past experience and provide valuable guidance on what can be achieved, as they seek to implement Flexible Routing.

- **United States:**

FAA published a number of PBN procedures to deliver more direct routes, saving time and fuel and reducing emissions. Specifically, the FAA published 50 required RNP authorization required and published 12 RNAV routes.

Alaska Airlines is saving more than 217 flight miles per day and nearly 200,000 gallons of fuel per year by using parallel flight routes, or Q routes, between Seattle, Portland and Vancouver on one end, and airports in the San Francisco Bay and Los Angeles basin areas on the other. The initial parallel routes were developed in 2004 in partnership with the FAA.

- **Oceanic areas:**

Pacific Region: DARPS, Dynamic Air route Planning System, used with flexible tracks and reduced horizontal separation to 30 NM using RNP 4 and automatic dependent surveillance (ADS) and controller pilot data link communications (CPDLC).

## 7.2 Planned or Ongoing Activities

- [ASPIRE](#)

Using [ATOP](#) conflict probe capabilities and improved communications techniques with the operators, a limited number of oceanic trajectory optimization demonstration flights were performed in 2008 in partnership with Air Europa. These demonstrations resulted in fuel savings of 0.5 percent-1 percent, validating the concept. During 2009, the additional partners participated in 119 oceanic optimization flights over the Atlantic. According to initial data analysis, the estimated fuel savings from re-routings on these flights averaged 1.4 percent, equivalent to about 230 gallons of fuel and more than 2 tons of carbon dioxide reductions per flight.

The 2008-09 demonstrations were limited to westbound routes and lateral rerouting. In 2010, the lateral reroute procedures tests continued, and the FAA initiated investigations on the benefits of vertical rerouting and eastbound routes. In addition, Automatic Dependent Surveillance-Contract climb and descent procedures were conducted in an operational trial over the Pacific Ocean to examine a reduction in oceanic separation from 30 miles to 15 miles, in an effort to better accommodate more efficient and user-preferred routes.

The ASPIRE initiative was launched in 2008 by the United States, Australia and New Zealand. Japan joined it in October 2009 and Singapore in January 2010. United Airlines, Qantas and Air New Zealand flew the original demonstrations. Japan Airlines' first demonstration flight, a Boeing 747 operating from Honolulu to Osaka, explored NextGen concepts such as user-preferred route and dynamic airborne rerouting capabilities, plus a number of weight- and energy-saving techniques. In gate-to-gate demonstrations of emissions reduction on transpacific routes, the average fuel saving during en route operations was 2.5 percent.

In its annual report for 2009, issued before Japan joined, ASPIRE estimated that if all 156 transpacific flights per week between Australia, New Zealand, the United States and Canada operated under conditions adopted for its demonstrations, airlines would save more than 10 million gallons of fuel and avoid more than 100,000 tons of carbon emissions per year. Air New Zealand in October 2009 cited



ASPIRE as a significant contributor to a fuel saving of 10 percent and a reduction of more than 385,000 tons of carbon emissions in its 2009 financial year compared with the previous year.

- DARP: Dynamic Airborne Reroute Procedure (DARP)

Flights take advantage of the six hourly update of the upper air wind and temperature forecast to effectively re-plan the flight en-route through a procedure called a DARP. This process can be completed as forecasts become available. Use of DARP commences with an aircraft data link request for a DARP to the Air New Zealand Flight Dispatch Office in Auckland. Immediately the latest wind/temperature forecast becomes available, the Flight Dispatch Officer recalculates the optimum track from a predetermined point just ahead of the current aircraft airborne position. Once calculated the revised route is uplinked to the aircraft for the crew to consider. The crew then downlink a request for the revised route to the Oceanic Control Centre and once approved, accept the revised route into the active side of the Flight Management Computer (FMC). Savings vary greatly from day to day dependent on the accuracy of the original forecast, the average AKL-SFO flight would save 70 US Gallons

## 8. Reference Documents

### 8.1 Standards

- ICAO Doc 4444, *Procedures for Air Navigation Services — Air Traffic Management*, Chapter 5

### 8.2 Procedures

Nil

### 8.3 Guidance Material

- ICAO Doc 9426, *Air Traffic Services Planning Manual*;
- ICAO Doc 9554, *Manual Concerning Safety Measures Relating to Military Activities Potentially Hazardous to Civil Aircraft Operations*;
- ICAO Doc 9613, *Performance-based Navigation (PBN) Manual*;
- ICAO Doc 9689, *Manual on Airspace Planning Methodology for the Determination of Separation Minima*;
- ICAO Global Collaborative Decision Making (CDM) Guidelines (under development);
- ICAO Circular 330 AN/189, *Civil/Military Cooperation in Air Traffic Management*.

### 8.4 Approval Documents

- ICAO Doc 9426, *Air Traffic Services Planning Manual*;
- ICAO Doc 9689, *Manual on Airspace Planning Methodology for the Determination of Separation Minima*;
- ICAO Doc 9613, *Performance-based Navigation (PBN) Manual*;
- ICAO Doc 9554, *Manual Concerning Safety Measures Relating to Military Activities Potentially Hazardous to Civil Aircraft Operations*;
- ICAO Global Collaborative Decision Making (CDM) Guidelines (under development)
- ICAO Circular 330 AN/189 *Civil/Military Cooperation in Air Traffic Management*.

## Module N° B1-10: Improved Operations through Free Routing

<b>Summary</b>	To provide, through <a href="#">PBN</a> , closer and consistent route spacing, curved approaches, parallel offsets and the reduction of holding area size. This will allow the sectorisation of airspace to be adjusted more dynamically. This will reduce potential congestion on trunk routes and busy crossing points and reduce controller workload. The main goal is to allow flight plans to be filed with a significant part of the intended route specified by the user-preferred profile. Maximum freedom will be granted within the limits posed by the other traffic flows. The overall benefits are reduced fuel burn and emissions.	
<b>Main Performance Impact</b>	KPA-02 Capacity, KPA-04 Efficiency, KPA-05 Environment; KPA-06 Flexibility	
<b>Operating Environment/Phases of Flight</b>	En-route, TMA, incl. Oceanic & Remote areas	
<b>Applicability Considerations</b>	Region or sub-region: the geographical extent of the airspace of application should be large enough; significant benefits arise when the dynamic routes can apply across <a href="#">FIR</a> boundaries rather than imposing traffic to cross boundaries at fixed pre-defined points.	
<b>Global Concept Component(s)</b>	AOM – Airspace Organisation and Management	
<b>Global Plan Initiatives (GPI)</b>	GPI-1 Flexible use of airspace GPI-8 Collaborative airspace design and management	
<b>Pre-Requisites</b>	B0-10	
<b>Global Readiness Checklist</b>		<b>Status</b> (ready now or estimated date)
	Standards Readiness	✓
	Avionics Availability	✓
	Ground System Availability	✓
	Procedures Available	<b>Est. 2018</b>
	Operations Approvals	<b>Est. 2018</b>

### 1. Narrative

#### 1.1 General

##### 1.1.1 Baseline

The baseline is the use of published routes and fixed sectors; some of them possibly defined flexibly as a result of FUA, or to better accommodate flows and/or other flight conditions such as weather. Published routes cannot afford for individual flight requirements as they are designed for significant/regular flows; typically flights from/to small airports with infrequent traffic will seldom find their optimum route pre-designed. In addition, published routes offer little freedom once they are published. This issue can be solved by authorizing flights to fly direct from a certain position to another point downstream their trajectory; this is generally a benefit to airspace users, but at the price of a significant workload for [ATC](#).

In addition, where/when traffic flows and density justifies the pre-arrangement of traffic over published routes as a means to systemise traffic management by ATC and maximize the resulting capacity, the dispersion of navigational errors, especially during turns of aircraft equipped with traditional RNAV, leads to apply spacing based on that dispersion and prevents the achievement of an efficient route design.



### 1.1.2 Change brought by the module

The module is the opportunity to exploit further PBN capabilities, beyond the benefits achieved by B0-10, in order to continue eliminating design constraints and operating more flexibly.

The module is made of the following elements:

- Free routing;
- Reduced route spacing;
- Dynamic sectorisation.

#### 1.2 *Element 1: Free Routing*

Free routing correspond to the ability for flights to file a flight plan with at least a significant part of the intended route which is not defined according to published route segments but specified by the airspace users. It is a user-preferred route, not necessarily a direct route, but the flight is supposed to be executed along the direct route between any specified way-point.

The use of free routing may be subject to conditions, in particular inside a defined volume of airspace, at defined hours, for defined flows. Its use may be limited to traffic under a certain density in order for controllers to be able to perform conflict detection and resolution with limited automation and while still being fully in the loop.

It is also in these conditions of density that the greater freedom for individual flights is less to be traded-off against the achievement of capacity objectives at the network level.

This module would mark the greatest advancement in terms of routings by providing maximum individual freedom. However, it is also recognized in the Global Concept that there are conditions where individual freedom has to give way to a more collective handling of traffic flows so as to maximize the overall performance.

The benefits of free routing are primarily in terms of adherence to the user-preferred profile. ATC may need to be provided with the necessary tools to ensure flight progress monitoring and coordination activities, and conflict prediction.

#### 1.3 *Element 2: Reduced Route Spacing*

A key tenet of the PBN concept is to combine the accuracy and functionality of navigation in specifications which can be tailored to the intended operations.

A serious problem with the use of classical RVAV in the last decades has not been the achieved accuracy on straight segments, but the behaviour of aircraft in transiting phases, especially turns, where significant differences are noted from one aircraft to the next and depending on conditions such as wind. This has resulted in the inability to exploit the intrinsic accuracy and to design better routes, due to the need to protect large volumes of airspace.

This element addresses not only routes. It also provides improvements to other issues related to lateral navigation and can be summarized as follows:

- Closer route spacing, particularly en route;
- Maintaining same spacing between routes on straight and turning segments without a need to increase route spacing on the turn;
- Reduction of the size of the holding area to permit holds to be placed closer together or in more optimum locations;
- Aircraft ability to comply with tactical parallel offset instructions as an alternative to radar vectoring;
- Means of enabling curved approaches, particularly through terrain rich areas.

The selection of a suitable PBN specification will eliminate the above shortcomings, and allow to design in both en-route and TMA routes which require lower spacing between them, directly resulting in higher airspace capacity, additional design flexibility and generally more efficient routes as well.

A safety assessment which considers operational errors may be required for the introduction of the reduced route spacing.

### 1.4 Element 3: Dynamic Sectorisation

The improvements in the design of the route network or the possibility to fly outside of a fixed route network make the pattern and concentration of traffic not always the same. Where sectorisation is designed to create capacity for ATC, the implementation of the above elements requires that the sectorisation be adjusted more dynamically than only in strategic ATC phases.

This dynamic sectorisation can take several forms, the most complex/dynamic ones with real-time design computing are considered beyond Block 1. In this module, dynamic sectorisation can take simple forms such as:

- a pre-defined volume of airspace being swapped from a sector to an adjacent sector;
- catalogues of pre-defined sector configurations based on a defined mosaic of elementary volumes, allowing a more general application of the above;
- sectors based on an organized (dynamic) track structure.

The dynamic sectorisation is applied in real-time by selecting the most suitable configuration among those available. Unlike grouping/de-grouping of sectors, it does not affect the number of control position in use. Dynamic sectorisation should be based on an assessment of the traffic situation expected in the next minute/hour.

Dynamic sectorisation can also be applied across [FIR/ANSP](#) boundaries.

## 2. Intended Performance Operational Improvement

**Metrics to determine the success of the module are proposed in the *Manual on Global Performance of the Air Navigation System (Doc 9883)*.**

<i>Capacity</i>	<p>The availability of a greater set of routing possibilities allows reducing potential congestion on trunk routes and at busy crossing points. This in turn allows reducing controller workload by flight.</p> <p>Free routings naturally spreads traffic in the airspace and the potential interactions between flights, but also reduces the “systematisation” of flows and therefore may have a negative capacity effect in dense airspace if it is not accompanied by suitable assistance.</p> <p>Reduced route spacing means reduced consumption of airspace by the route network and greater possibility to match it with flows.</p>
<i>Efficiency</i>	<p>Trajectories closer to the individual optimum by reducing constraints imposed by permanent design and/or by the variety of aircraft behaviours. In particular the module will reduce flight length and related fuel burn and emissions. The potential savings are a significant proportion of the ATM related inefficiencies.</p> <p>Where capacity is not an issue, fewer sectors may be required as the spreading of traffic or better routings should reduce the risk of conflicts.</p> <p>Easier design of high-level Temporary Segregated Airspace (TSAs).</p>
<i>Environment</i>	<p>Fuel burn and emissions will be reduced; however, the area where emissions and contrails will be formed may be larger.</p>
<i>Flexibility</i>	<p>Choice of routing by the airspace user would be maximized. Airspace designers would also benefit from greater flexibility to design routes that fit the natural traffic flows.</p>
<a href="#">CBA</a>	<p>The business case of free routing has proven to be positive due to the benefits that flights can obtain in terms of better flight efficiency (better routes and vertical profiles; better and tactical resolution of conflicts).</p>

### 3. Necessary Procedures (Air & Ground)

The airspace requirements (RNAV, RNP and the value of the performance and functionality required) may require new ATS procedures and ground system functionalities. Some of the ATS procedures required for this module are linked with the processes of notification, coordination and transfer of control. Care needs to be taken so that the development of the required ATM procedures provides for a consistent application across regions.

### 4. Necessary System Capability

#### 4.1 Avionics

Aircraft need to be suitably equipped. This is a matter of accuracy and functionality, i.e. a suitable PBN specification(s).

#### 4.2 Ground Systems

An adequate navigation infrastructure in the airspace of application is required that may be provided by ground navigation aids. For free routings, the flight planning and the flight data processing functionalities need to be upgraded to support the air traffic controller with the means to understand/visualise the flight paths and their interactions, as well as to communicate with adjacent controllers.

Dynamic sectorisation requires the flight data processing functionality to be able to work with different sector configurations and sector grouping/de-grouping functionality. This functionality is available in many systems today.

### 5. Human Performance

#### 5.1 Human Factors Considerations

5.1.1 The change step is achievable from a human factors perspective. The roles and responsibilities of controller/pilot are not affected. Free routing, when compared to a structured route system, can reduce the number of potential interactions between flights but makes their occurrence less predictable and their configurations more variable. This is why it needs to be supported by automated assistance to understand/visualise the flight paths and their interactions as soon as traffic is significant. It is easier to implement it progressively, e.g. starting in low traffic conditions/periods. Reduced route spacing has no direct human performance incidence.

5.1.2 The identification of Human Factors considerations is an important enabler in identifying processes and procedures for this module. In particular, the human-machine interface for the automation aspects of this performance improvement will need to be considered and where necessary accompanied by mitigation risk mitigation strategies such as training, education and redundancy.

#### 5.2 Training and Qualification Requirements

5.2.1 Training in the operational standards and procedures will be identified along with the standards and recommended practices necessary for this module to be implemented. Likewise the qualifications requirements will be identified and included in the regulatory readiness aspects of this module when they become available

### 6. Regulatory/standardization needs and Approval Plan (Air & Ground)

- **Regulatory/Standardization:** Use current published requirements that includes the material give in Section 8.4.
  - ICAO Doc 9426, *Air Traffic Services Planning Manual*;
  - ICAO Doc 9689, *Manual on Airspace Planning Methodology for the Determination of Separation Minima*;
  - ICAO Doc 9613, *Performance-based Navigation (PBN) Manual*;
  - ICAO Doc 9554, *Manual Concerning Safety Measures Relating to Military Activities Potentially Hazardous to Civil Aircraft Operations*;
  - Updates to ICAO Doc 4444 for new ATS procedures in PAN-ATM

- **Approval Plans:** To Be Determined, based upon regional applications. Specific PBN Applications such as Advanced RNP may be necessary

## 7. Implementation and Demonstration Activities

### 7.1 Current Use

- **US:** NRS Waypoints are currently implemented in the US since 2005. The approximately 1600 waypoints are spaced evenly covering the continental United States. Flights can file using the NRS Waypoints instead of VORs to take advantage of RNAV capabilities.
- **Europe:** several States have declared their airspace as “free routes”: Ireland, Portugal, Sweden or planning to do so (Albania, Benelux-Germany in Maastricht UAC, Cyprus, Denmark, Finland, Estonia, Latvia, Malta, Norway on a 24-hour basis; Bulgaria, Greece, Hungary, Italy, Romania, Serbia at night).

A CBA conducted in 2001 for a Free Route Airspace (FRA) implementation initially planned in Europe in 2006 concluded as follows:

FRA is planned to be introduced in 8 European States: Belgium, Denmark, Finland, Germany, Luxembourg, the Netherlands, Norway and Sweden. This CBA has assumed that it will be introduced from the end of 2006 and in the airspace above Flight Level 335.

The total costs of implementing FRA are estimated at € 53M, incurred mostly in 2005 and 2006. The benefit (reduced flight distances and times due to more direct flights) in the first year of operation, 2007, is € 27M, and the benefit is expected to increase each year with traffic growth. FRA is likely to become ‘financially beneficial’ (i.e. the financial benefits will be greater than the costs) because the costs are mostly incurred once while the benefits cumulate year on year. The CBA shows that, under the baseline assumptions, the cumulative benefits will overtake the costs in 2009. Over the 10 year project lifetime, from 2005 to 2014, the project has a Net Present Value (NPV) of € 76M and an Internal Rate of Return (IRR) of 40%.

The costs of FRA do not fall evenly to all stakeholders. Aircraft operators flying [GAT](#) (mostly civilian airlines) receive almost all the financial benefits. The main costs fall to civil and military Air Traffic Service Providers (ATSP) and Air Defence units that must implement changes to their ground systems. Their costs differ according to how much work they must do to implement the necessary changes for FRA. The range of ATSP costs is from less than € 1M (Denmark) to € 10M (Germany).

An estimate of the approximate costs and benefits to each State has been made. The analysis shows that, for most States, the total of [ATC](#) and Air Defence costs of FRA are much less than the benefit delivered to civil traffic in those States. For Germany, for example, FRA has an estimated NPV of € 53M when comparing all of the [DFS](#) ATC costs and Germany’s AD costs against the benefit that DFS will deliver to civil traffic. For Norway, however, FRA has a small net cost because Norway has relatively high system upgrade costs to support FRA. Belgium and the Netherlands are a special case. In these States, the Maastricht UAC will deliver a benefit to civil traffic in FRA, but their military ATC and Air Defence organisations will still incur costs to implement [FRA](#). In particular, the Belgian and Netherlands Air Forces will pay over € 9M to implement FRA and not see any significant financial benefits.

### 7.2 Planned or Ongoing Activities

- **SESAR:** Trials on User Preferred Routing within Functional Airspace Blocks environment in a predetermined area and time period in 2012.

Trials on User Preferred Routing Operations from TMA exit to TMA entry in the timeframe 2014-2015.

## 8. Reference Documents

### 8.1 Standards

- ICAO Doc 4444, *Procedures for Air Navigation Services — Air Traffic Management*, Chapter 5;

### 8.2 Procedures

### 8.3 Guidance Material

- ICAO Doc 9426, *Air Traffic Services Planning Manual*;

- ICAO Doc 9554, *Manual Concerning Safety Measures Relating to Military Activities Potentially Hazardous to Civil Aircraft Operations*;
- ICAO Doc 9613, *Performance-based Navigation (PBN) Manual*;
- ICAO Doc 9689, *Manual on Airspace Planning Methodology for the Determination of Separation Minima*;
- ICAO Global Collaborative Decision Making (CDM) Guidelines (under development);
- ICAO Circular 330 AN/189 Civil/Military Cooperation in Air Traffic Management.

#### **8.4 Approval Documents**

- ICAO Doc 9426, *Air Traffic Services Planning Manual*;
- ICAO Doc 9689, *Manual on Airspace Planning Methodology for the Determination of Separation Minima*;
- ICAO Doc 9613, *Performance-based Navigation (PBN) Manual*;
- ICAO Doc 9554, *Manual Concerning Safety Measures Relating to Military Activities Potentially Hazardous to Civil Aircraft Operations*;
- Updates to ICAO Doc 4444 for new ATS procedures in PAN-ATM.

## Module N° B3-10: Traffic Complexity Management

<b>Summary</b>	Introduction of complexity management to address events and phenomena that affect traffic flows due to physical limitations, economic reasons or particular events and conditions by exploiting the more accurate and rich information environment of a SWIM-based ATM. Benefits will include, optimized usage and efficiency of system capacity,	
<b>Main Performance Impact</b>	KPA-02 Capacity; KPA-04 Efficiency; KPA-06 Flexibility; KPA-09 Predictability	
<b>Operating Environment/Phases of Flight</b>	Pre-flight and in-flight	
<b>Applicability Considerations</b>	Regional or sub-regional. Benefits are only significant over a certain geographical size and assume that it is possible to know and control/optimize relevant parameters. Benefits mainly useful in the higher density airspace	
<b>Global Concept Component(s)</b>	AOM – Airspace Organisation and Management TS – Traffic Synchronization DCB – Demand & Capacity Balancing	
<b>Global Plan Initiatives (GPI)</b>	GPI-6 Air traffic flow management GPI-8 Collaborative airspace design and management	
<b>Pre-Requisites</b>	Successor of: B1-10, B2-35 Parallel progress with: B3-05, B3-15, B3-25, B3-85	
<b>Global Readiness Checklist</b>		<b>Status</b> (ready now or estimated date)
	Standards Readiness	<b>Est. 2028</b>
	Avionics Availability	<b>Est. 2028</b>
	Ground Systems Availability	<b>Est. 2028</b>
	Procedures Available	<b>Est. 2028</b>
	Operations Approvals	<b>Est. 2028</b>

### 1. Narrative

#### 1.1 General

With 4D trajectory operations, Block 3 will see the achievement of capabilities which optimize the individual trajectories, the traffic flows and the use of scarce resources such as runways and surface. This module is focused on the capabilities needed to solve issues related to the increased complexity of certain traffic situations.

While Trajectory-based Operations are the long-term evolution of the management of an individual trajectory, a number of events and phenomena affect traffic flows due to physical limitations, economic reasons or particular events and conditions. The long-term evolution of their management is addressed in this module in relation with traffic densities higher than the present ones, and/or with a view to improve the solutions applied so far and provide optimized services while working closer to the system limits. This is referred to as “managing complexity”.

The module integrates various ATM components to generate its extra performance benefits and will introduce further refinements in DCB, TS and AOM processes (and possibly SDM, AUO and AO) to exploit

the more accurate and rich information environment expected from TBO, SWIM and other longer term evolutions.

This is an area of active research, where innovative solutions are probably as important as the understanding of the uncertainties inherent to ATM and of the air transport mechanisms and behaviours to which ATM performance is sensitive to.

### 1.1.1 Baseline

Prior to this module, most of the ingredients of the Global ATM Concept will have been progressively put in place, but not yet completely pending the dissemination of a certain number of capabilities and enablers, and also not fully integrated. There remains room to achieve performance gains by addressing the issues that the lack of optimized integration will raise.

### 1.1.2 Change brought by the module

The module provides for the optimization of the traffic flows and air navigation resources usage. It addresses the complexity within ATM due to the combination of higher traffic densities, more accurate information on trajectories and their surrounding environment, closely interacting processes and systems, and the quest for greater levels of performance.

## 2. Intended Performance Operational Improvement

Metrics to determine the success of the module are proposed in the *Manual on Global Performance of the Air Navigation System (Doc 9883)*.

<i>Capacity</i>	Increase and optimized usage of system capacity.
<i>Efficiency</i>	Optimization of the overall network efficiency.
<i>Flexibility</i>	Accommodation of change requests.
<i>Predictability</i>	Minimise the impact of uncertainties and unplanned events on the smooth running of the ATM system.

<i>CBA</i>	To be established as part of the research related to the module.
------------	--

## 3. Necessary Procedures (Air & Ground)

To be defined.

## 4. Necessary System Capability

The module will exploit technology then available, in particular SWIM and TBO which will provide the accurate information on the flights and their environment. It will also likely rely on automation tools.

### 4.1 Avionics

None in addition to that required for participation in SWIM and/or TBO operations.

### 4.2 Ground Systems

Intensive use of automated functions and sophisticated algorithms to exploit information

## 5. Human Performance

### 5.1 Human Factors Considerations

**5.1.1** The high degree of integration of the traffic information and the optimization of the processes will likely require high levels of automation and the development of specific interfaces for the human operators.

**5.1.2** This module is still in the research and development phase so the human factors considerations are still in the process of being identified through modelling and beta testing. Future iterations of this document

will become more specific about the processes and procedures necessary to take the human factors considerations into account. There will be a particular emphasis on identifying the human-machine interface issue if there are any and providing the high risk mitigation strategies to account for them.

## **5.2 Training and Qualification Requirements**

**5.2.1** Training requirements will be high, not only prior to entry into service but also as a regular maintenance of the skills.

**5.2.2** This module will eventually contain and number of personnel training requirements. As and when they are developed, they will be included in the documentation supporting this module and their importance signified. Likewise, any qualifications requirements that are recommended will become part of the regulatory needs prior to implementation of this performance improvement.

## **6. Regulatory/standardization needs and Approval Plan (Air & Ground)**

- Regulatory/Standardization: To Be Determined
- Approval Plans: To Be Determined.

## **7. Implementation and Demonstration Activities**

### **7.1 Current Use**

None at this time.

### **7.2 Planned or Ongoing Activities**

- **Europe:** the SESAR programme has established a research network on “complexity” together with research projects addressing some of the relevant issues.
- **US:** research is being conducted at NASA and Universities.

No live trials in the foreseeable future.

## **8. Reference Documents**

### **8.1 Standards**

### **8.2 Procedures**

### **8.3 Guidance Material**



## **Performance Improvement Area 3: Optimum Capacity and Flexible Flights – Through Global Collaborative ATM.**

*Thread: Network Operations*

This Page Intentionally Left Blank

## Module N° B0-35: Improved Flow Performance through Planning based on a Network-Wide view

<b>Summary</b>	Air Traffic Flow Management (ATFM) is used to manage the flow of traffic in a way that minimizes delay and maximizes the use of the entire national airspace. ATFM can regulate traffic flows involving departure slots, smooth flows and manage rates of entry into airspace along traffic axes, manage arrival time at waypoints or <a href="#">FIR</a> /Sector boundaries and re-route traffic to avoid saturated areas. ATFM may also be used to address system disruptions including crisis caused by human or natural phenomena.	
<b>Main Performance Impact</b>	KPA-01 Access & Equity; <b>KPA-02 Capacity</b> ; KPA-04 Efficiency; KPA-05 Environment; KPA-08 Participation by the ATM community; KPA-09 Predictability	
<b>Operating Environment/Phases of Flight</b>	Pre-flight phases, some action during actual flight.	
<b>Applicability Considerations</b>	Region or sub-region	
<b>Global Concept Component(s)</b>	DCB – Demand-Capacity Balancing TS – Traffic Synchronization AOM – Airspace Organisation and Management	
<b>Global Plan Initiatives (GPI)</b>	GPI-1 Flexible use of airspace GPI-6 Air traffic flow management GPI-8 Collaborative airspace design and management	
<b>Pre-Requisites</b>	NIL	
<b>Global Readiness Checklist</b>		<b>Status (ready now or estimated date)</b>
	Standards Readiness	<b>2013</b>
	Avionics Availability	<b>N/A</b>
	Ground Systems Availability	<b>✓</b>
	Procedures Available	<b>2013</b>
	Operations Approvals	<b>2013</b>

### 1. Narrative

#### 1.1 General

The techniques and procedures brought by this module capture the experience and state-of-the-art of the current [ATFM](#) systems in place in some regions, and which have developed as they were facing demand-capacity imbalances. Global ATFM Seminars and bi-lateral contacts have allowed to disseminate good practices.

Experience clearly shows the benefits related to managing flows consistently and collaboratively over an area of a sufficient geographical size to take into account sufficiently well the network effects. The concept for ATFM/DCB should be further exploited wherever possible. System improvements are also about better procedures in these domains, and creating instruments to allow collaboration among the different actors.

Overall, to meet the objectives of balancing demand and capacity, keeping delays to a minimum and avoiding congestion, bottlenecks and overload, ATFM undertakes flow management in three broad phases. Each flight will usually have been subjected to these phases, prior to being handled operationally by ATC.

Strategic [ATFCM](#) activity takes place during the period from several months until a few days before a flight. During this phase, comparison is made between the expected air traffic demand and the potential ATC capacity. Objectives are set for each ATC unit in order for them to provide the required capacity. These objectives are monthly reviewed in order to minimise the impact of the missing capacity on the airspace users. In parallel, an assessment of the number and routings of flights, which aircraft operators are planning, enables ATFM to prepare a routing scheme, balancing the air traffic flows in order to ensure maximum use of the airspace and minimise delays.

Pre-tactical [ATFCM](#) is action taken during the few days before the day of operation. Based on the traffic forecasts, the information received from every [ATC](#) centre covered by the [ATFM](#) service, statistical and historical data, the ATFM Notification Message (ANM) for the next day is prepared and agreed through a collaborative process. The ANM defines the tactical plan for the next (operational) day and informs Aircraft Operators (AOs) and ATC units about the [ATFCM](#) measures that will be in force on the following day. The purpose of these measures is not to restrict but to manage the flow of traffic in a way that minimises delay and maximizes the use of the entire airspace.

Tactical [ATFCM](#) is the work carried out on the current operational day. Flights taking place on that day receive the benefit of [ATFCM](#), which includes the allocation of individual aircraft departure times, re-routings to avoid bottlenecks and alternative flight profiles to maximize efficiency.

ATFM has also progressively been used to address system disruptions and evolves into the notion of management of the performance of the Network under its jurisdiction, including management of crises provoked by human or natural phenomena.

### 1.1.1 Baseline

It is difficult to describe an exact baseline. The need for ATFM has emerged as traffic densities increased, and it took form progressively. It is observed that this need is now spreading progressively over all continents, and that even where overall capacity is not an issue, the efficient management of flows through a given volume of airspace deserves a specific consideration at a scale beyond that of a sector or an [ACC](#), in order to better plan resources, anticipate on issues and prevent undesired situations.

### 1.1.2 Change brought by the module

ATFM has developed progressively over the last 30 years. It is noticeable from the European experience that key steps have been to be able to predict traffic loads for the next day with a good accuracy, to move from measures defined as rate of entry into a given piece of airspace (and not as departure slots) to measures implemented before take-off and taking into account the flows/capacities in a wider area. More recently the importance of proposing alternative routings rather than only a delay diagnosis has been recognized, thereby also preventing over-reservations of capacity. ATFM services offer a range of web-based or B2B services to [ATC](#), airports and aircraft operators, actually implementing a number of CDM applications.

In order to regulate flows, [ATFM](#) may take measures of the following nature:

- Departure slots ensuring that a flight will be able to pass the sectors along its path without generating overflows;
- Rate of entry into a given piece of airspace for traffic along a certain axis;
- Requested time at a way-point or an FIR/sector boundary along the flight;
- Miles-in-trail figures to smooth flows along a certain traffic axis;
- Re-routing of traffic to avoid saturated areas;
- sequencing of flights on the ground by applying departure time intervals (MDI);
- level capping;
- delaying of specific flights on the ground by a few minutes ("Take Off Not Before").

These measures are not mutually exclusive. The first one has been the way to resolve the problem of multiple interacting flow regulation measures addressed independently by several ATFM units in Europe before the creation of the CFMU and proved to be more efficient than the second one which pre-existed CFMU.

## 2. Intended Performance Operational Improvement

Metrics to determine the success of the module are proposed in the *Manual on Global Performance of the Air Navigation System (Doc 9883)*.

<i>Access and Equity</i>	Improved access by avoiding disruption of air traffic in periods of demand higher than capacity; <a href="#">ATFM</a> processes take care of equitable distribution of delays.
<i>Capacity</i>	Better utilization of available capacity, network-wide; in particular the trust of <a href="#">ATC</a> not being faced by surprise to saturation tends to let it declare/use increased capacity levels; ability to anticipate difficult situations and mitigate them in advance.
<i>Efficiency</i>	Reduced fuel burn due to better anticipation of flow issues; a positive effect to reduce the impact of inefficiencies in the ATM system or to dimension it at a size that would not always justify its costs (balance between cost of delays and cost of unused capacity);  Reduced block times and times with engines on.
<i>Environment</i>	Reduced fuel burn as delays are absorbed on the ground, with shut engines; rerouting however generally put flight on a longer distance, but this is generally compensated by other airline operational benefits.
<i>Participation by the ATM community</i>	Common understanding of operational constraints, capabilities and needs.
<i>Predictability</i>	Increased predictability of schedules as the <a href="#">ATFM</a> algorithms tends to limit the number of large delays.
<i>Safety</i>	Reduced occurrences of undesired sector overloads.
<a href="#">CBA</a>	The business case has proven to be positive due to the benefits that flights can obtain in terms of delay reduction.

## 3. Necessary Procedures (Air & Ground)

An ICAO manual on ATFM is available in draft version and need to be .completed and approved. US/Europe experience is enough to help initiate application in other regions.

New procedures are required to link much closer the ATFM with ATS in the case of using miles-in-trail or Arrival management or Departure management (see module B0-15).

## 4. Necessary System Capability

### 4.1 Avionics

No avionics requirements.

### 4.2 Ground Systems

When serving several FIRs, ATFM systems are generally deployed as a specific unit, system and software connected to the ATC units and airspace users to which it provides its services. Regional ATFM units have been the subject of specific developments. The main system functions for an ATFM systems are: demand and capacity balancing, performance measurements & monitoring, network operations plan management and traffic demand management.

Some vendors propose light ATFM systems.

## 5. Human Performance

### 5.1 Human Factors Considerations

**5.1.1** Controllers are protected from overloads and have a better prediction of their workload. ATFM does not interfere in real-time with their ATC tasks. However, Human Factors have been taken into consideration during the development of the processes and procedures associated with this module. Where automation is to be used, the Human-Machine interface has been considered from both a functional and ergonomic perspective (See Section 6 for examples). The possibility of latent failures however, continues to exist and vigilance is requested during all implementation actions. It is further requested that human factor issues, identified during implementation, be reported to the international community through ICAO as part of any safety reporting initiative.

### 5.2 Training and Qualification Requirements

**5.2.1** Flow managers in the flow management unit and controllers in ACCs using the remote flow management information or applications needs specific training and airline dispatchers using the remote flow management information or applications need training.

**5.2.2** Training in the operational standards and procedures are required for this module and can be found in the links to the documents in Section 8 to this module. Likewise, the qualifications requirements are identified in the regulatory requirements in Section 6 which form an integral part to the implementation of this module.

## 6. Regulatory/standardization needs and Approval Plan (Air & Ground)

- **Regulatory/Standardization:** New standards and requirements is required for standard ATFM messages;
- **Approval Plans:** To Be Determined.

## 7. Implementation and Demonstration Activities

### 7.1 Current Use

- **Europe:** Detailed Example – Network Operations Plan (CFMU)

The NOP portal was launched in February 2009 and as it exists today is a recognized major step on simplifying the ATM partners' access to ATM information. The NOP portal through one application provides one single view for all partners of several relevant ATM information like: - a map displaying the air traffic flow information, including the status of the congested areas in Europe and a corresponding forecast for the next three hours; - scenarios and events enriched with context and cross-reference information; - the collaborative process for building the season operations plan is now formalized; - the summary information of the preceding day is now immediately available with access to archive reports.

- **United States:** Detailed Example – National Playbook (ATCSCC)

The National Playbook is a traffic management tool developed to give all stakeholders a common product for various system wide route scenarios. The purpose is to aid in expediting route coordination during periods of reduced capacity in the ATM System that occur en route or at the destination airport. The playbook contains the most common scenarios that occur each severe weather season. The "play" includes the resource or flow impacted, facilities included, and specific routes for each facility involved

### 7.2 Planned or Ongoing Activities

- **Europe:** The following improvement items are being validated or implemented in Europe for 2013 or earlier:
  - Enhanced Flight Plan Filing Facilitation;
  - Use of Free Routing for flight in special Airspace volumes;
  - Shared Flight Intentions;
  - Use of Aircraft Derived Data to enhance ATM ground system performance;
  - Automated Support for Traffic Load Management;
  - Automated Support for Traffic Complexity Assessment;
  - Network Performance Assessment;

- Moving Airspace Management into day of operation;
  - Enhanced Real-time Civil-Military Coordination of Airspace Utilization;
  - Flexible Sectorisation management;
  - Modular Sectorisation adapted to Variations in traffic flow;
  - Enhanced [ASM/ATFCM](#) coordination Process;
  - Short Term [ATFCM](#) Measures;
  - Interactive Network Capacity Planning;
  - SWIM enabled [NOP](#);
  - Management of Critical Events;
  - Collaborative Management of Flight updates;
  - ATFM Slot Swapping;
  - Manual User Driven Prioritisation Process.
- **United States** – Plans are currently being developed to test operational feasibility of strategic planning using severe weather and traffic forecast in the 24-48 hour timeframes.

## 8. Reference Documents

### 8.1 Standards

TBD

### 8.2 Procedures

TBD

### 8.3 Guidance Material

- ICAO Global Collaborative Decision Making (CDM) Guidelines (under development).

### 8.3 Approval Documents

- ICAO Doc XXXX, Global CDM Guidance Material (in preparation).

## Module N° B1-35: Enhanced Flow Performance through Network Operational Planning

<b>Summary</b>	To introduce enhanced processes to manage flows or groups of flights in order to improve overall flow. The resulting increased collaboration among stakeholders in real-time regarding user preferences and system capabilities will result in better use of airspace with positive effects on the overall cost of ATM.	
<b>Main Performance Impact</b>	KPA-02 Capacity; KPA-04 Efficiency; KPA-05 Environment; KPA-09 Predictability; KPA-10 Safety,	
<b>Operating Environment/Phases of Flight</b>	Mainly applicable to pre-flight phases, with some application in flight.	
<b>Applicability Considerations</b>	Region or sub-region for most applications; specific airports in case of initial UDPP. This module is more particularly needed in areas with the highest traffic density. However, the techniques it contains would also be of benefit to areas with lesser traffic, subject to the business case	
<b>Global Concept Component(s)</b>	DCB Demand-Capacity Balancing TS Traffic Synchronization AOM Airspace Organisation and Management	
<b>Global Plan Initiatives (GPI)</b>	GPI-1 Flexible use of airspace GPI-6 Air traffic flow management GPI-8 Collaborative airspace design and management	
<b>Pre-Requisites</b>	Successor of: B0-35, B0-10 ( <a href="#">FUA</a> aspects in particular)	
<b>Global Readiness Checklist</b>		<b>Status</b> (ready now or estimated date)
	Standards Readiness	<b>Est. 2018</b>
	Avionics Availability	<b>NA</b>
	Ground Systems Availability	<b>Est. 2018</b>
	Procedures Available	<b>Est. 2018</b>
	Operations Approvals	<b>Est. 2018</b>

### 1. Narrative

#### 1.1 General

This module introduces enhanced processes to manage flows or groups of flights in order to improve overall fluidity. It also increases the collaboration among stakeholders in real time so as to better know user preferences, inform on system capabilities, and further apply CDM in a certain set of problems/circumstances, in particular to take into account priorities of an airline among flights within its schedule. It also extends the notion of flexible use of airspace so as to include network efficiency considerations.

##### 1.1.1 Baseline

The previous module, B0-35, provided a solid foundation for regulating traffic flows, and B0-10 introduced flexible use of airspace (FUA). The experience shows that further improvements can be introduced: managing airspace and traffic flows needs to be better integrated into the notion of network operations,



[ATFM](#) techniques and algorithms can be improved and in particular could better take into account user preferences.

### **1.1.2 Change brought by the module**

This module introduces enhanced processes to manage flows or groups of flights in order to improve overall fluidity. This module refines ATFM techniques, integrates the management of airspace and traffic flows in order to achieve greater efficiency in their management. It also increases the collaboration among stakeholders in real time so as to better know user preferences, inform on system capabilities and further apply [CDM](#) in a certain set of problems/circumstances in particular to take into account priorities of an airline among flight within its schedule.

#### **1.2 Element 1: Improved [ATFM](#) and AFTM-AOM integration**

Studies have shown that there is room for improvement of the ATFM algorithms and techniques. The module will implement those that will have been validated in the period of reference.

A particular development is required to accommodate the use of free routings implemented in B1-10.

In addition, with ATFM having introduced the notion of re-routing, either for [ATC](#) capacity constraints or to avoid other phenomena such as severe weather, it appears that a greater integration of ATFM and airspace management would bring significant benefits to traffic, not only civil traffic, but also for the more dynamic definition of areas which may be used for military.

#### **1.3 Element 2: Synchronization**

When getting really closer to capacity limits, the small variations in take-off time allowed by ATFM slots may still generate local bunching of traffic at times, which are extremely sensitive at a small number of choke-points in the network. It would therefore be useful to be able to anticipate on these situations once the flight is airborne and the uncertainties on its trajectory are reduced compared to before take-off, by using trajectory predictions and perform additional smoothing, not only along a flow (miles in trail) but for several converging flows at a few number of most critical choke points in a given airspace.

#### **1.4 Element 3: Initial UDPP**

User Driven Prioritisation Process is designed to allow airspace users to intervene more directly in the implementation of flow regulations, in particular in cases where an unplanned degradation of capacity significantly impacts the realisation of their schedule. The module proposes a simple mechanism by which the affected airlines can collaboratively among themselves and with [ATFM](#) come to a solution which takes into account their commercial/operational priorities which are not known by ATM. Due to the potential complexity of several intricate prioritisation and allocation processes, this module will implement UDPP only in specific situations, e.g. when the perturbation affects one airport.

#### **1.5 Element 4: Full FUA**

ICAO development of FUA documentation on civil/military cooperation

The full FUA introduces mechanisms, in conjunction with the more dynamic ATS routes (module B1-10) to make the airspace and its use as flexible as possible and a continuum that can be used in an optimal manner by the civil and military users.

#### **1.6 Element 5: Complexity Management**

The introduction of improved complexity and workload assessment tools is a means to improve the accuracy and reliability of the identification and mitigation of capacity constraints, both in the tactical ATFM phase as well as during the flight. This exploits information on planned incoming traffic.

## 2. Intended Performance Operational Improvement

Metrics to determine the success of the module are proposed in the *Manual on Global Performance of the Air Navigation System (Doc 9883)*.

<i>Capacity</i>	Better use of the airspace and ATM network, with positive effects on the overall cost-efficiency of ATM. Optimization of DCB measures by using assessment of workload/complexity as a complement to capacity.
<i>Efficiency</i>	Reduction of flight penalties supported by airspace users.
<i>Environment</i>	Some minor improvement is expected compared to the module's baseline.
<i>Predictability</i>	Airspace users have a greater visibility and say on the likelihood to respect their schedule and can make better choices based on their priorities.
<i>Safety</i>	The module is expected to further reduce the number of situations where capacity or acceptable workload would be exceeded.

<a href="#">CBA</a>	The business case will be a result of the validation work being undertaken.
---------------------	---

## 3. Necessary Procedures (Air & Ground)

There is a need to develop:

- New procedures to exploit the new techniques: for ATC to communicate in-flight measures to crews; for informing operators before departure.
- Rules for information exchange and decision making between all the actors
- UDPP rules and application requirements will need be defined.

## 4. Necessary System Capability

### 4.1 Avionics

No avionics impact.

### 4.2 Ground Systems

Building on the systems established to deliver B0-35, this module will require additional ground functionality in the form of enhanced algorithms, interactive services with ANSPs and aircraft operators through B2B applications, and connections with airspace management systems, either to integrate them or to receive in real-time airspace management information in conjunction with B1-10 module.

## 5. Human Performance

### 5.1 Human Factors Considerations

**5.1.1** Roles and responsibilities of controllers and pilots are expected not to be much affected in tactical operations (except by the more tactical re-routings or sequencing), but will need to understand that the decisions made on flights are for the common good.

**5.1.2** The identification of Human Factors considerations is an important enabler in identifying processes and procedures for this module. In particular, the human-machine interface for the automation aspects of this performance improvement will need to be considered and where necessary accompanied by mitigation risk mitigation strategies such as training, education and redundancy.

### 5.2 Training and Qualification Requirements

**5.2.1** The new procedures will require training adapted to the collaborative nature of the interactions, in particular between [ATFM](#) and airline operations personnel.

**5.2.2** Training in the operational standards and procedures will be identified along with the standards and recommended practices necessary for this module to be implemented. Likewise the qualifications requirements will be identified and included in the regulatory readiness aspects of this module when they become available.

## **6. Regulatory/standardization needs and Approval Plan (Air & Ground)**

- **Regulatory/Standardization:** Updates as required for enhanced operations in ICAO Doc 4444, *Procedures for Air Navigation Services — Air Traffic Management*;
- **Approval Plans:** To Be Determined.

## **7. Implementation and Demonstration Activities**

### **7.1 Current Use**

- **Europe:** Some European ACCs already exploit complexity management tools to better predict sector workloads and take measures such as de-grouping to absorb traffic bunching effects.

### **7.2 Planned or Ongoing Activities**

- **Europe:** SESAR will validate the initial UDPP requirements and procedures, as well as the airspace management and network operations related to the module.

## **8. Reference Documents**

### **8.1 Standards**

### **8.2 Procedures**

### **8.3 Guidance Material**

EUROCONTROL Concept 'Advanced Flexible Use of Airspace (AFUA).

### **8.4 Approval Documents**

ICAO Doc 4444, *Procedures for Air Navigation Services — Air Traffic Management*.

## Module N° B2-35: Increased user involvement in the dynamic utilization of the network

<b>Summary</b>	<p><a href="#">CDM</a> applications supported by SWIM that permit airspace users to manage competition and prioritisation of complex <a href="#">ATFM</a> solutions when the network or its nodes (airports, sector) no longer provide enough capacity to meet user demands. This further develops the CDM applications by which ATM will be able to offer/delegate to the users the optimization of solutions to flow problems.</p> <p>Benefits include an improvement in the use of available capacity and optimized airline operations in degraded situations.</p>	
<b>Main Performance Impact</b>	KPA-02 Capacity; KPA-09 Predictability	
<b>Operating Environment/Phases of Flight</b>	Pre-flight phases	
<b>Applicability Considerations</b>	Region or sub-region	
<b>Global Concept Component(s)</b>	DCB-Demand-Capacity Balancing TS-Traffic Synchronization AOM-Airspace Organisation and Management AUO-Airspace Users Operations	
<b>Global Plan Initiatives (GPI)</b>	GPI-6 Air traffic flow management GPI-8 Collaborative airspace design and management	
<b>Pre-Requisites</b>	B1-35, B1-30 and probably B2-25	
<b>Global Readiness Checklist</b>		<b>Status</b> (ready now or estimated date)
	Standards Readiness	<b>Est. 2023</b>
	Avionics Availability	<b>Est. 2023</b>
	Ground Systems Availability	<b>Est. 2023</b>
	Procedures Available	<b>Est. 2023</b>
	Operations Approvals	<b>Est. 2023</b>

### 1. Narrative

#### 1.1 General

##### 1.1.1 Baseline

The previous module, B1-35, has introduced an initial version UDPP, focused on the issues at an airport.

##### 1.1.2 Change brought by the module

This module further develops the CDM applications by which ATM will be able to offer/delegate to the users the optimization of solutions to flow problems, in order to let the user community take care of competition and their own priorities in situation when the network or its nodes (airports, sector) does no longer provide actual capacity commensurate with the satisfaction of the schedules. This module also builds on SWIM for more complex situations.

## 2. Intended Performance Operational Improvement

Metrics to determine the success of the module are proposed in the *Manual on Global Performance of the Air Navigation System (Doc 9883)*.

<i>Capacity</i>	Improved use of the available capacity in situations where it is constrained.
<i>Predictability</i>	The module offers airlines the possibility to have their priorities taken into account and optimize their operations in degraded situations.

<a href="#">CBA</a>	To be established when the research on the module has progressed more significantly
---------------------	---

## 3. Necessary Procedures (Air & Ground)

Procedures are required to specify the conditions (in particular rules of participation, rights and duties, equity principles, etc) and notice for UDPP to be applicable. The process will need to be done in a way that does not conflict with or degrades the optimization of the network done by [ATFM](#).

## 4. Necessary System Capability

### 4.1 Avionics

None in addition to that required for participation in SWIM where applicable.

### 4.2 Ground Systems

Will be supported by SWIM environment technology and ground-ground integration with all participants especially ATS and airlines.

Automated functions allowing negotiation among users and connection with ATFM systems

## 5. Human Performance

### 5.1 Human Factors Considerations

**5.1.1** No significant issues identified. Nevertheless, the module will introduce additional factors in the decision making related to flight preparation and planning which will need to be understood by airline personnel.

**5.1.2** This module is still in the research and development phase so the human factors considerations are still in the process of being identified through modelling and beta testing. Future iterations of this document will become more specific about the processes and procedures necessary to take the human factors considerations into account. There will be a particular emphasis on identifying the human-machine interface issue if there are any and providing the high risk mitigation strategies to account for them.

### 5.2 Training and Qualification Requirements

**5.2.1** The new procedures will require training adapted to the collaborative nature of the interactions, in particular between ATFM and airline operations personnel.

**5.2.2** This module will eventually contain a number of personnel training requirements. As and when they are developed, they will be included in the documentation supporting this module and their importance signified. Likewise, any qualifications requirements that are recommended will become part of the regulatory needs prior to implementation of this performance improvement.

## 6. Regulatory/standardization needs and Approval Plan (Air & Ground)

- **Regulatory/Standardization:** New standards and guidance needed to enable user optimization of CDM solutions.
- **Approval Plans:** To Be Determined.

## **7. Implementation and Demonstration Activities**

### **7.1 Current Use**

None at this time.

### **7.2 Planned or Ongoing Activities**

- **Europe:** SESAR work programme has just started to formulate the concept of UDPP, and will need to elaborate this module further before describing the trials for it.

## **8. Reference Documents**

### **8.1 Standards**

### **8.2 Procedures**

### **8.3 Guidance Material**

### **8.4 Approval Documents**

This Page Intentionally Left Blank

## **Performance Improvement Area 3: Optimum Capacity and Flexible Flights – Through Global Collaborative ATM.**

***Thread: Initial Surveillance***



This Page Intentionally Left Blank

## Module N° B0-84: Initial capability for ground surveillance

<b>Summary</b>	This module provides initial capability for lower cost ground surveillance supported by new technologies such as ADS-B OUT and wide area multilateration systems. This capability will be expressed in various ATM services, e.g. traffic information, search and rescue and separation provision.	
<b>Main Performance Impact</b>	KPA- 02 Capacity, KPA-10 Safety	
<b>Operating Environment/Phases of Flight</b>	All airborne flight phases in continental or subsets of oceanic airspace and on aerodrome surfaces	
<b>Applicability Considerations</b>	This capability is characterized by being dependent and cooperative. The overall performance is affected by ADS-B out performance and equipage.	
<b>Global Concept Component(s)</b>	CM – Conflict Management	
<b>Global Plan Initiatives (GPI)</b>	GPI-9 Situational awareness GPI-16 Decision support and alerting systems	
<b>Main Dependencies</b>	NIL	
<b>Global Readiness Checklist</b>		<b>Status</b> (ready now or estimated date)
	Standards Readiness	<b>Ready now</b>
	Avionics Availability	<b>Ready now</b>
	Ground Systems Availability	<b>Ready now</b>
	Procedures Available	<b>Ready now</b>
	Operations Approvals	<b>Ready now</b>

### 1. Narrative

#### 1.1 General

The surveillance service delivered to users may be based on a mix of three main types of surveillance as defined in ICAO Doc 9924:

Independent Non-Cooperative Surveillance: The aircraft position is derived from measurement not using the cooperation of the remote aircraft.

Independent Cooperative Surveillance: The position is derived from measurements performed by a local surveillance subsystem using aircraft transmissions. Aircraft-derived information (e.g. pressure altitude, aircraft identity) can be provided from those transmissions.

Dependent Cooperative Surveillance: The position is derived on board the aircraft and is provided to the local surveillance subsystem along with possible additional data (e.g. aircraft identity, pressure altitude).

The module describes the cooperative surveillance services.

#### 1.1.1 Baseline

Currently, air to ground aircraft position and surveillance is accomplished through the use of primary and secondary radar surveillance. The Primary surveillance radar derives aircraft position based on radar echo returns. The secondary radar is used to transmit and receive aircraft data for barometric altitude, identification code. However, current primary and secondary radars cannot be easily sited in oceanic

locations, or rough terrain such as in mountainous regions, and have a heavy reliance on mechanical components with large maintenance tails.

### **1.1.2 Change brought by the module**

This module introduces the opportunity to expand ATC radar equivalent service with two new surveillance techniques that can be used, separately or jointly: ADS-B and multilateration. These techniques provide alternatives to classic radar technology at a lower implementation and maintenance cost, thereby allowing to provide surveillance services in areas where there are currently not available for geographical or cost reasons. These techniques also allow, in certain conditions, a reduction of separation minima thereby potentially increasing the ability to accommodate larger volumes of traffic.

#### **1.2 Element 1: ADS-B**

Dependent surveillance with accurate position sources such ADS-B is recognized as one of the important enablers of several of the ATM operational concept components including traffic synchronization and conflict management (Recommendation 1/7, AN-Conf/11, 2003). The transmission of ADS-B information (ADS-B out) is already used for surveillance in some non-radar areas (Block 0).

Dependent surveillance is an advanced surveillance technology that allows avionics to broadcast an aircraft's identification, position, altitude, velocity, and other information. The surveilled broadcasted aircraft position is more accurate than with conventional Secondary Surveillance Radar (SSR) because it is normally based on the Global Position System (GPS) and transmitted at least once per second. The inherent accuracy of the GPS determined position and the high update rate will provide service providers and users improvements in safety, capacity, and efficiency. Note: ADS-B is dependent upon having a source of required positional accuracy (such as GNSS today).

Operationally, the lower costs of dependent surveillance infrastructure in comparison to conventional radars support business decisions to expand radar equivalent service volumes and the use of radar-like separation procedures into remote or non-radar areas. In addition to lower costs, the non-mechanical nature of the ADS-B ground infrastructure allows it to be sited in locations that are difficult for radar installations. For example, in the Gulf of Mexico, ADS-B Receiver stations are installed on oil platforms to provide radar-like services using ADS-B as the surveillance source. Compared to non-radar services, flights are flying more direct routes, and service providers are able to handle more traffic in each sector.

Use of dependent surveillance also improves the Search and Rescue support provided by the surveillance network. In non-radar areas, such as the Gulf of Mexico, ADS-B's positional accuracy and update rate allows for improved flown trajectory tracking allowing for early determination of loss of contact and enhances the ability for Search and Rescue teams to pinpoint the related location.

Additionally, dependent surveillance information can be an enabler for sharing of surveillance data across FIR boundaries and significantly improves the performance of predictive tools using aircraft derived velocity vector and vertical rate data. It also downlinks other useful ATC relevant data similar to Mode S DAPS.

ADS-B-OUT Standards and Recommended Practices (SARPs) (ICAO Annex 10, Volume IV and Doc 9871) and MOPS (RTCA-DO260-B/ Eurocae ED102-A) are available. AN-Conf/11 recommended ADS-B on 1090MHz for international use and this is happening. Equipage rate is growing together with Mode S, ACAS and ADS-B Out mandates. It is pointed out that ADS-B OUT version 2 also provides for ACAS RA DOWNLINK information in support of monitoring activities currently only possible in SSR Mode S coverage.

#### **1.3 Element 2: Multilateration**

Multilateration technique is a new technique providing independent cooperative surveillance. Its deployment is made easier by the use of Airborne Mode S equipment capability with the spontaneous transmission of messages (Squitters). In this case the signal transmitted by aircraft is received by a network of receivers located at different places. The use of the different times of arrival at the different receivers allows an independent determination of the position of the source of signals. This technique can be passive and use the existing transmissions made by the aircraft or be active and trigger replies in the manner of Mode S SSR interrogations. Surveillance of conventional Mode A/C transponders requires that they be interrogated.

Multilateration systems were initially deployed on main airports to make the surveillance of aircraft on the surface. The technique is now used to provide surveillance over wide area (Wide Area Multilateration system

- WAM). Multilateration requires more ground stations than ADS-B and has large geometric requirements than ADS-B, but has the early implementation advantage of using current aircraft equipage.

## 2. Intended Performance Operational Improvement/Metric to determine success

<i>Safety</i>	Reduction of the number of major incidents. Support to Search and Rescue
<i>Capacity</i>	Typical separation minima are 3 NM or 5 NM enabling a significant increase in traffic density compared to procedural minima.  Improved coverage, capacity, velocity vector performance and accuracy can improve ATC performance in both radar and non radar environments. Terminal area surveillance performance improvements are achieved through high accuracy, better velocity vector and improved coverage.
<i>CBA</i>	- either comparison between procedural minima and 5NM separation minima would allow an increase of traffic density in a given airspace  -or comparison between installing/renewing SSR Mode S stations using Mode S transponders and installing ADS-B OUT (and /or Multilateration systems).

## 3. Necessary Procedures (Air & Ground)

The relevant PANS-ATM (Doc 4444) provisions are available.

## 4. Necessary System Capability

### 4.1 Avionics

For ADS-B surveillance services, aircraft must be equipped with ADS-B OUT. Accuracy and integrity are reported from the avionics. Users of the data decide on the required accuracy and integrity for the application.

For multilateration, aircraft need to be equipped with Mode S radar transponders.

### 4.2 Ground Systems

Units providing surveillance services must be equipped with a ground-based surveillance data processing system able to process and display the aircraft positions. Connection to a flight data processing system allows positive identification by correlating positions and flight data.

Units may provide ADS-B surveillance in environments where there is full or partial avionics equipage depending on the capabilities and procedures of the ATC system.

ATC Systems must also be designed to enable the delivery of separation services between ADS-B-to-ADS-B and ADS-B-to-radar **and fused targets**.

## 5. Human Performance

### 5.1 Human Factors Considerations

The air traffic controller has a direct representation of the traffic situation, and reduces the task of controllers or radio operators to collate position reports.

### 5.2 Training and Qualification Requirements

**5.2.1** Controllers must receive specific training for separation provision, information service and search and rescue based on the ADS-B and WAM systems in use.

**5.2.2** Training in the operational standards and procedures are required for this module and can be found in the links to the documents in Section 8 to this module. Likewise, the qualifications requirements are identified in the regulatory requirements in Section 6 which form an integral part to the implementation of this module.

### 5.3 Others

Nil

## 6. Regulatory/standardization needs and Approval Plan (Air & Ground)

Nil

## 7. Implementation and Demonstration Activities

### 7.1 Current Use

ASMGCS systems using multilateration technology are operational at many locations worldwide.

**Australia** - ADS-B is operational throughout the Australian continent for delivery of 5 NM separation services in radar and non-radar areas, in continental and oceanic airspace. ADS-B data sharing between Indonesia and Australia is fully operational allowing safety nets and situational awareness at the boundary. WAM is operational in Sydney Australia supporting 3 NM TMA separation and PRM operations. WAM is operational in Tasmania, Australia supporting en-route separation.

**United States** – ADS-B surveillance coverage for continental United States will be completed in 2013.

### 7.2 Planned or Ongoing Trials

Currently in use at this time.

## 8. Reference Documents

### 8.1 Standards

- ICAO ANNEX 10 — Aeronautical Telecommunications, Volume IV — Aeronautical Radio Frequency Spectrum Utilization;
- ICAO DOC 9871, *Technical Provisions for Mode S Services and Extended Squitter*;
- RTCA MOPS DO260 and DO260A EUROCAE ED102 and ED102A.

### 8.2 Procedures

- ICAO Doc 4444, *Procedures for Air Navigation Services — Air Traffic Management*;

### 8.3 Guidance Material

- ICAO DOC 9924, *Aeronautical Surveillance Manual*;
- ICAO *Assessment of ADS-B and Multilateration Surveillance to Support Air Traffic Services and Guidelines for Implementation* (Circular 326);
- ICAO Asia Pacific : ADS-B IMPLEMENTATION AND OPERATIONS GUIDANCE DOCUMENT.

### 8.4 Approval Documents

## **Performance Improvement Area 3: Optimum Capacity and Flexible Flights – Through Global Collaborative ATM.**

***Thread: Self Separation***

This Page Intentionally Left Blank

## Module N° B0-85: Air Traffic Situational Awareness (ATSA)

<b>Summary</b>	Two <i>ATSA (Air Traffic Situational Awareness)</i> applications which will enhance safety and efficiency by providing pilots with the means to enhance traffic situational awareness and achieve quicker visual acquisition of targets: <ul style="list-style-type: none"> <li>• AIRB (Airborne Situational Awareness during Flight Operations). This will reduce the need for repeated air traffic advisories and thus increase operational efficiencies.</li> <li>• VSA (Visual Separation on Approach). This will improve efficiency and regularity of arrival traffic at airports..</li> </ul>	
<b>Main Performance Impact</b>	KPA-04 – Efficiency; KPA-10 – Safety	
<b>Operating Environment/Phases of Flight</b>	En-route, Terminal, Approach,	
<b>Applicability Considerations</b>	These are cockpit based applications which do not require any support from the ground hence they can be used by any suitably equipped aircraft. This is dependent upon aircraft being equipped with ADS-B out.  Avionics availability at low enough costs for GA is not yet available.	
<b>Global Concept Component(s)</b>	CM – Conflict Management; TS – Traffic Synchronization	
<b>Global Plan Initiatives (GPI)</b>	GPI-9 Situational Awareness; GPI-15 Match IMC and VMC operating capacity.	
<b>Pre-Requisites</b>		
		<b>Status</b> (ready now or estimated date).
<b>Global Readiness Checklist</b>	Standards Readiness	√
	Avionics Availability	√
	Infrastructure Availability	√
	Ground Automation Availability	N/A
	Procedures Available	√
	Operations Approvals	2012

### 1. Narrative

#### 1.1 General

Basic Airborne Situational Awareness during Flight Operations (AIRB), aims at improving flight safety and flight operations by assisting flight crews in building their traffic situational awareness through the provision of an appropriate on-board displays of surrounding traffic during all airborne phases of flight. It is expected that flight crews will perform their current tasks more efficiently; both in terms of decision-making and the resulting actions, and thus flight safety and flight operations should be enhanced. The actual benefits will vary depending on the airspace and operational flight rules.

Approaches flown where flight crews maintain own separation from the preceding aircraft may increase landing capacity and/or increase the number of movements achievable at many airports compared to rates obtained when ATC separation is applied. Through the use of an airborne traffic display, the “Visual Separation on Approach” application (VSA) will enhance this type of operation by providing improved visual acquisition of preceding aircraft and by extending the use of own separation clearances on approach.

#### 1.1.1 Baseline

AIRB and VSA applications are available and this constitutes the baseline.



### 1.1.2 Change brought by the module

This module provides various efficiency benefits at all stages of flight. AIRB applies to all phases of flight; VSA applies to the approach phase of flight. Although each application provides capacity and efficiency improvements, the mechanism for each of them is different.

Flight crews using the AIRB application which is the most basic Aircraft Surveillance (AS) application and is used as the foundation for all the other applications described in this document. The application uses cockpit displays to provide the flight crew with a graphical depiction of traffic using relative range and bearing, supplemented by altitude, flight ID and other information. It is used to assist the out-the-window visual acquisition of airborne traffic and enables the flight crew to build traffic situational awareness for traffic beyond visual range.

The display enables detection of traffic by the flight crew and aids in making positive identification of traffic advised by ATC. The information provided on the display is also expected to reduce the need for repeated air traffic advisories and is expected to increase operational efficiencies.

The objective of the ATSA-VSA application is to make it an own separation approach procedure easier and more reliable for flight crews to visually acquire the preceding aircraft and by supporting them in maintaining own separation from the preceding aircraft. This application will improve efficiency, safety and regularity of arrival traffic at airports. In addition to the traffic information provided by the controller, the traffic display will support the flight crew in the visual search for the preceding aircraft whenever this one is equipped with ADS B OUT. Additionally, the traffic display will provide up to date information that will support the flight crews to visually maintain a safe and not unnecessarily large distance and to detect unexpected speed reductions of the preceding aircraft. In these situations, the flight crew will be able to manoeuvre by adjusting own speed more precisely whilst maintaining the preceding aircraft in sight. The objective is not to reduce the distance between the two aircraft in comparison with current operations when own separation is applied but it is to avoid that this distance becomes too low due to a late detection of unexpected closing situation. The use of the traffic display is expected to support improved visual acquisition of preceding aircraft, and extend the use of own separation clearances on approach.

Voice communications associated with traffic information are expected to be reduced. Safety of operations improvement is expected as it is anticipated that this procedure will decrease the likelihood of wake turbulence encounters. Some efficiency benefits are also expected to be derived when the preceding and succeeding aircraft are approaching the same runway because of a reduction in the number of missed approaches.

#### **Element 1: ATSA-AIRB**

AIRB application can be used in all types of aircraft fitted with certified equipment. (ADS-B IN and a traffic display). The details are provided below.

AIRB application can be used in all types of airspaces, from class A to class G. The use of this application is independent of the type of ATC surveillance (if any) and of the type of air traffic services provided in the airspace in which the flight is conducted.

#### **Element 2: ATSA-VSA**

The application is mainly intended for air transport aircraft but it can be used by all suitably equipped aircraft during approach to any airports where own separation is used.

## 2. Intended Performance Operational Improvement/

Metrics to determine the success of the module are proposed at Doc 9883.

<i>Efficiency</i>	Improve situational awareness to identify level change opportunities with current separation minima (AIRB) and improve visual acquisition and reduction of missed approaches (VSA)
<i>Safety</i>	Improve situational awareness (AIRB) and reduce the likelihood of wake turbulence encounters (VSA)

CBA	<p>The benefit is largely driven by higher flight efficiency and consequent savings in contingency fuel.</p> <p>The benefit analysis of the EUROCONTROL CRISTAL ITP project of the CASCADE Programme and subsequent update had shown that ATSAW AIRB and ITP together are capable of providing the following benefits over N. Atlantic</p> <ul style="list-style-type: none"> <li>- saving 36 million Euro (50k Euro per aircraft) annually and</li> <li>- reducing carbon dioxide emissions by 160,000 tonnes annually.</li> </ul> <p>The majority of these benefits are attributed to AIRB. Findings will be refined after the completion of the pioneer operations starting in December 2011.</p>
-----	--

### 3. Necessary Procedures (Air & Ground)

The procedure for the use of ADS-B traffic display is being proposed for inclusion in the PANS OPS Doc8168) for applicability in Nov. 2013.

### 4. Necessary System Capability

#### 4.1 Avionics

ADS-B OUT compliant with AMC2024 / DO-260A/DO-260B /ED102 A is needed on the majority of the aircraft population. There is a potential need to certify ADS-B OUT data.

ADS-B IN compliant with DO-314 / ED160 or DO-317A / ED194 is required to support VSA

ADS-B IN compliant with DO-319 / ED164 or DO-317A / ED194 is required to support AIRB.

#### 4.2 Ground Systems

In some environments (e.g. USA) it is anticipated to modify ground infrastructure to provide ADS-R and TIS-B.

### 5. Human Performance

#### 5.1 Human Factors Considerations

Eurocontrol FC guidance AIRB v0.5 section 3.1

The AIRB and VSA applications does not change roles and responsibilities for controllers and pilots.

The controllers remain responsible for the provision of separation between aircraft in compliance with the definition of the Air Traffic Services.

The pilots are still responsible for the safe and efficient control and navigation of their individual aircraft in all airspace. In controlled airspace, they still have to follow the clearances and instructions provided by controllers. The only difference in comparison with current operations is that pilot's procedures will include the use of the Traffic Display to enhance traffic situational awareness. It is the flight crew's decision to use the AIRB or VSA application.

Eurocontrol FC guidance AIRB v0.5 section 2.5

Flight crew must be aware that there can be surrounding aircraft that are not displayed on the Traffic Display for various reasons (surrounding aircraft without ADS-B OUT capability, emitting non-qualified data, or out of the display volume, and traffic display de-cluttering for traffic on ground).

#### 5.2 Training and Qualification Requirements

ED164 AIRB SPR, section 3.7

Flight crews must be trained on the proper use of AIRB and VSA applications. Several aspects which should be addressed in training include overreliance on the Traffic Display to the detriment of other sources of information, excessive head-down time, awareness of latency issues and operation in a partial ADS-B equipage environment.

- It is important to provide appropriate training for the flight crews to use and understand the Traffic Display and how the information is presented on it.
- Training on the use of the AIRB and VSA applications should emphasize the use of the Traffic Display as supplemental information to existing sources of information, so as to avoid overreliance on the AIRB and VSA applications to the detriment of other sources or interference with existing procedures.
- Flight crews, especially if flying VFR, should be trained to avoid excessive head-down time to the detriment of regular out the window scans.
- Training should address the evolution of the traffic situation, considering that the displayed information is continuously updated and can vary from the information received from the controller, which is based on a past situation.
- Training should ensure flight crews are aware that the traffic picture displayed may be incomplete, due to a partial equispace situation, or filtering of poor quality data.
- Periodic refresher training on the proper use of the AIRB and VSA applications should be provided to prevent flight crew complacency when using the Traffic Display as a supplemental source of traffic information.

Additionally, the following training consideration should also be taken into account:

- Training should also be provided on the hazard of misinterpreting the Traffic Display and manoeuvring inappropriately because the display provides only partial information and is based upon a moving reference.
- Training should ensure flight crews are aware of the need to reference the TCAS Traffic Display for assistance in the visual acquisition of traffic when a Traffic Advisory is generated by TCAS and TCAS traffic is shown on a separate display.

## 1.2 Others

ED164 AIRB SPR, section 3.7

Special attention should be given to training for General Aviation (GA) flight crews regarding the appropriate uses of the AIRB and VSA applications. Some expected means of providing this information and emphasizing the appropriate uses and limitations of displayed AIRB Traffic to the GA community include, but are not limited to the following: Airplane Flight Manual Supplements (AFMS), training material supplied directly from the avionics manufacturer, specific training during bi-annual Flight Reviews, and direct instructions from fixed-base operators during any rental checkout procedures.

## 6. Regulatory/standardization needs and Approval Plan (Air and Ground)

- **Regulatory/Standardization:** Use current published criteria that includes the material given in Section 8.4;
- **Approval Plans:** To Be Determined. Operational Approval guidance/criteria may be needed based upon regional application for [ATSA](#);

## 7. Implementation and Demonstration Activities

### 7.1 Current Use

- **US** – ADS-B / TIS-B / FIS-B services will be available over continental US by 2013.
- **EUROPE** – AIRB has been used operationally from Feb. 2012 (by Swiss International Airlines) in the context of the ATSAW Pioneer project of the EUROCONTROL CASCADE Programme. The other pioneer airlines (British Airways, Delta Airlines, US Airways and Virgin Atlantic,) will follow.

### 7.2 Planned or Ongoing Activities

Currently in Operation

## **8. Reference Documents**

### **8.1 Standards**

- EUROCAE ED-160 / RTCA DO-314, Safety, Performance and Interoperability Requirements Document for Enhanced Visual Separation on Approach (ATSA-VSA)
- EUROCAE ED-164 / RTCA DO-319, Safety, Performance and Interoperability Requirements Document for Enhanced Traffic Situational Awareness During Flight Operations (ATSA-AIRB)

### **8.2 Procedures**

The procedure for the use of ADS-B traffic display is being proposed for inclusion in the PANS OPS Doc8168) for applicability in Nov. 2013.

### **8.3 Guidance Material**

- EUROCONTROL Flight Crew Guidance on Enhanced Traffic Situational Awareness during Flight Operations;
- EUROCONTROL Flight Crew Guidance on Enhanced Visual Separation on Approach;
- EUROCONTROL ATSAW Deployment Plan (draft);
- Draft ICAO Manual on Airborne Surveillance Applications (Doc XXXX) available 2012.

### **8.4 Approval Documents**

- RTCA/EUROCAE ASA MOPS, DO-317A/ED-194;
- AC 20-172;
- TSO C195.

## Module N° B1-85: Increased Capacity and Efficiency through Interval Management

<b>Summary</b>	Interval Management (IM) improves the management of traffic flows and aircraft spacing. This creates operational benefits through precise management of intervals between aircraft with common or merging trajectories, thus maximizing airspace throughput while reducing ATC workload along with more efficient aircraft fuel burn reducing environmental impact.	
<b>Main Performance Impact</b>	KPA-03 Cost-Effectiveness, KPA-04 Efficiency, KPA-05 Environment and KPA-10 Safety.	
<b>Operating Environment/Phases of Flight</b>	En-Route, Arrival, Approach, Departure.	
<b>Applicability Considerations</b>	En-route and terminal areas.	
<b>Global Concept Component(s)</b>	DCB – Demand and Capacity Balancing; TS –Traffic Synchronization; CM – Conflict Management	
<b>Global Plan Initiatives (GPI)</b>	GPI-7 Dynamic and Flexible ATS Route Management;GPI-9 Situational Awareness; GPI-17 Data Link Applications.	
<b>Pre-Requisites</b>	B0-85	
<b>Global Readiness Checklist</b>		<b>Status</b> (ready now or estimated date).
	Standards Readiness	Est. 2014
	Avionics Availability	Est. 2016
	Ground System Availability	Est.2014
	Procedures Available	Est.2014
	Operations Approvals	Est.2016
		Est.2016

### 1. Narrative

#### 1.1 General

Interval Management is defined as the overall system that enables the improved means for managing traffic flows and aircraft spacing, including the use of ground tools that assist the controller in evaluating the traffic picture and determining appropriate clearances to merge and space aircraft efficiently and safely and the use of airborne tools that allow the flight crew to conform with the IM Clearance. The objective is for an instructed aircraft to achieve and/or maintain an assigned interval relative to another one. The interval can be defined in time or distance.

IM operations in the first phase will cover the arrival phase of flight (from the top of descent to initial or final approach fix) of airspace under surveillance, where Direct Controller Pilot Communications (voice or CPDLC) exist. As the applications evolve they will be applied to other phases of flight.

IM includes both the ground capabilities needed for the controller to support an IM Clearance and the airborne capabilities needed for the flight crew to follow the IM Clearance.

IM application is also seen as a complement to Continuous Descent Operations (CDO) by enabling fuel-efficient near-idle continuous descent profiles. The joint use of CDO and IM is expected to allow for CDOs in higher density traffic than where they are currently used.

**1.1.1 Baseline**

In the current Ground-Based ATM the management of intervals between aircraft in a sequence is performed by the air traffic controller through speed adjustments and radar vectors. This is a task that generates significant workload since it requires intensive monitoring and involves a series of radio communications and clearances. Change brought by the module

Interval Management is a suite of functional capabilities that can be combined into a set of specific operational applications to achieve or maintain an interval or spacing between a given aircraft and a target aircraft. ATC will be provided with a new set of (voice or data link) instructions directing, for example, that the flight crew establish and maintain a given time from the target aircraft. These new instructions will reduce the use of ATC vectoring and speed control, which is expected to reduce the overall number of transmissions. These reductions are expected to reduce ATC workload per aircraft.

The flight crew will perform these new tasks using new avionics functions e.g. airborne surveillance, display of traffic information, and spacing functions with advisories. A few examples of Interval Management in various phases of flight include: Cruise - delivering metering or miles-in-trail prior to top-of-descent; Arrival – interval management during optimum profile descents to merge (if applicable); Approach – achieve and maintain appropriate interval to stabilized approach point; and Departure – maintain interval no-closer-than to previous departure. These examples provide more efficient flight trajectories, better scheduling performance, reduced fuel burn and decreased environmental impacts.

**2. Intended Performance Operational Improvement**

Metrics to determine the success of the module are proposed at Doc 9883

<i>Cost-Effectiveness</i>	Consistent, low variance spacing between paired aircraft (e.g., at the entry to an arrival procedure and on final approach) resulting in reduced fuel burn.
<i>Efficiency</i>	Early speed advisories removing requirement for later path-lengthening Continued Optimized Profile Descents (OPDs) in medium density environments <ul style="list-style-type: none"> <li>○ expected to allow OPDs when demand &lt;=70%</li> </ul> Resulting in reduced holding times and flight times.
<i>Environment</i>	All efficiency benefits have an impact of the environment. Resulting in reduced emissions.
<i>Safety</i>	Reduced ATC instructions and workload <ul style="list-style-type: none"> <li>○ Without unacceptable increase in flight crew workload</li> </ul>

CBA	TBD
-----	-----

**3. Necessary Procedures (Air & Ground)**

Air and Ground Procedures for Interval Management have yet to be developed. They will include conditions of application, phraseology and messages exchanges.

**4. Necessary System Capability**

**4.1 Avionics**

Necessary technology includes ADS-B OUT for surrounding aircraft and ADS-B IN capability with a Cockpit Display of Traffic information (CDTI) and some cockpit automation for performing interval management operations. CPDLC in accordance with message set developed by SC-214 and WG-78 will be required.

**4.2 Ground Systems**

Ground automation to support the Interval Management application may be required. Where implemented this will most likely be customised based on the set of interval management procedures allowed in a given terminal area. This may include the implementation of additional CPDLC messages. For arrival operations an arrival manager (AMAN) tool is recommended.

## 5. Human Performance

### 5.1 Human Factors Considerations

Responsibility for separation is not modified; the controller is still responsible to ensure separation between these aircraft.

### 5.2 Training and Qualification Requirements

The pilot needs to be trained and qualified to assume the new tasks and to ensure a correct usage of the new procedures and avionics.

The controller needs to be trained and qualified to assume the tasks and to ensure a correct usage of the new procedures and ground support tools.

## 6. Regulatory/standardization needs and Approval Plan (Air and Ground)

- **Regulatory/Standardization:** Updated/new published criteria required that includes the material given in Sections 8.1 and 8.4.
- **Approval Plans:** TBD.

## 7. Implementation and Demonstration Activities

### 7.1 Current Use

In the US, operational trials of IM were conducted at Louisville (KY) from 2009 to 2010.

### 7.2 Planned or Ongoing Activities

- **SESAR:** Validation in TMA environment with PRNAV structure of the two basic ASAS sequencing and merging manoeuvres during 2012-2013 timeframe. **SESAR Project 05.06.06 ASPA-S&M** : The objective of P5.6.6 – “ASAS Sequencing and Merging” project is to contribute to the consolidation of the operational concept and to validate the “Airborne Spacing Sequencing & Merging Application” (ASPA S&M).
- **United States** – Plans are currently being developed to demonstrate the Flight Interval Management functionality in 2013 by NASA. The FAA is implementing the requirements for Ground Interval Management - Spacing (GIM-S) via two FAA automation programs: Time-Based Flow Management (TBFM) and ERAM. The FAA has several airline partners prepared to support operational data collection and benefits measurement as the initial FIM-S capabilities are established. The FAA supported the efforts of a joint RTCA/EUROCAE working group to develop the Safety, Performance and interoperability Requirements (SPR) document for FIM-S (also known as ASPA-IM), which resulted in RTCA DO-328. RTCA SC-186 and EUROCAE WG-51 have begun initial work on the MOPS material for FIM-S avionics. This effort is expected to conclude in late 2013.

## 8. Reference Documents

### 8.1 Standards

- EUROCAE ED-195 / RTCA DO-328, Safety, Performance and Interoperability Requirements Document for Airborne Spacing – Flight Deck Interval Management (ASPA-FIM);
- RTCA DO-XXXX, Enhanced CPDLC Message set per SC214/WG/78;
- ASA MOPS DO-317A/ED-194 will be updated to include FIM equipment standards by the end of 2013.
- Standards for FIM would need to be developed for Annex 10 Volume IV.

### 8.2 Procedures

TBD

### 8.3 Guidance Material

- EUROCONTROL, Flight Crew Guidance on Enhanced Traffic Situational Awareness during Flight Operations;
- EUROCONTROL, Flight Crew Guidance on Enhanced Situational Awareness on the Airport Surface;

- EUROCONTROL, Flight Crew Guidance on Enhanced Visual Separation on Approach.

#### **8.4 Approval Documents**

- RTCA DO-XXXX, Enhanced [CPDLC](#) Message set per SC214/WG78.



This Page Intentionally Left Blank

## Module N° B2-85 Airborne Separation (ASEP)

<b>Summary</b>	Creation of operational benefits through temporary delegation of responsibility to the flight deck for separation provision between suitably equipped designated aircraft, thus reducing the need for conflict resolution clearances while reducing <a href="#">ATC</a> workload and enabling more efficient flight profiles. The flight crew ensures separation from suitably equipped designated aircraft as communicated in new clearances, which relieves the controller of the responsibility for separation between these aircraft. However, the controller retains responsibility for separation from aircraft that are not part of these clearances. This will result in capacity increase and reduced controller workload, more optimal flight trajectories and less fuel consumption.	
<b>Main Performance Impact</b>	KPA-02 Capacity, KPA-04 Efficiency, KPA-05 Environment; KPA-06 Flexibility; KPA-09 Predictability	
<b>Operating Environment / Flight Phases</b>	En-route phase, oceanic, and approach, departure and arrival	
<b>Applicability Considerations</b>	The safety case need to be carefully assessed and the impact on capacity is still to be assessed in case of delegation of separation for a particular conflict implying new regulation on airborne equipment and equipage roles and responsibilities (new procedure and training). First applications of <a href="#">ASEP</a> are envisaged in Oceanic airspace and in approach for closely-spaced parallel runways.	
<b>Global Concept Component(s)</b>	CM- Conflict Management	
<b>Global Plan Initiatives (GPI)</b>	GPI-16 Decision support systems and alerting systems	
<b>Pre-Requisites</b>	B1-85,	
<b>Global Readiness Checklist</b>		<b>Status (ready or date)</b>
	Standards Readiness	Est. 2023
	Avionics Availability	Est. 2023
	Ground Systems Availability	Est. 2023
	Procedures Available	Est. 2023
	Operations Approvals	Est. 2023

### 1. Narrative

#### 1.1 General

Airborne separation is described as follows in the Global ATM Operational Concept (ICAO Doc 9854):

#### Cooperative separation

Cooperative separation occurs when the role of separator is delegated. This delegation is considered temporary, and the condition that will terminate the delegation is known. The delegation can be for types of hazards or from specified hazards. If the delegation is accepted, then the accepting agent is responsible for compliance with the delegation, using appropriate separation modes.”

#### 1.1.1 Baseline

The baseline is provided by the first [ASAS](#) application described in the modules B0-86 and B1-85. These ASAS-ASEP operations will be the next step.

### 1.1.2 Change brought by the module

This module will introduce new modes of separation relying on aircraft capabilities including airborne surveillance supported by [ADS-B](#) and giving responsibility for separation to the pilot by delegation from the controller. This relies on the definition of new Airborne Separation Minima.

With Element: Airborne separation (ASEP) the flight crew ensures separation from designated aircraft as communicated in new clearances, which relieve the controller from the responsibility for separation between these aircraft. However, the controller retains responsibility for separation from aircraft that are not part of these clearances and from aircraft involved in ASEP and surrounding aircraft.

#### Typical Airborne Separation applications include:

- In-descent separation: the flight crews maintain a time-based horizontal separation behind designated aircraft.
- Level flight separation: the flight crews maintain a time or distance-based longitudinal separation behind designated aircraft.
- Lateral crossing and passing: the flight crews adjust the lateral flight path to ensure that horizontal separation with designated aircraft is larger than the applicable airborne separation minimum.
- Vertical crossing: the flight crews adjust the vertical flight path to ensure that vertical separation with designated aircraft is larger than the applicable airborne separation minimum.
- Paired Approaches in which the flight crews maintain separation on final approach to parallel runways
- In oceanic airspace many procedures are considered as improvement of In Trail Procedure (ITP) using new airborne separation minima
  - [ASEP-ITF](#) In Trail Follow
  - [ASEP-ITP](#) In Trail Procedure
  - [ASEP-ITM](#) In Trail Merge

## 2. Intended Performance Operational Improvement

Metrics to determine the success of the module are proposed in the *Manual on Global Performance of the Air Navigation System (Doc 9883)*.

<i>Capacity</i>	Increase by allowing reduced separation minima and potential reduction of <a href="#">ATCO</a> workload
<i>Efficiency</i>	Optimum flight trajectories
<i>Environment</i>	Less fuel consumption due to more optimum flight trajectories
<i>Flexibility</i>	More flexibility to take in account change in constraint, weather situation
<i>Predictability</i>	Conflict resolution is optimized and potentially more standardized thanks to the airborne equipment performance standards.

<a href="#">CBA</a>	To be determined by balancing cost of equipment and training and reduced penalties
---------------------	--

## 3. Necessary Procedures (Air & Ground)

[ASAS-ASEP](#) procedures need to be defined for PANS-ATM and PANS-OPS with clarifications of roles and responsibilities.

## 4. Necessary System capability (Air & Ground)

### 4.1 Avionics

For ASEP and airborne separation delegation: Air-Ground data link and ADS-B Out and ADS-In airborne system associated to Airborne Separation Assistance Systems (ASAS). The ASAS is composed of two main functions i.e., airborne surveillance and conflict resolution.

## 4.2 Ground systems

On the ground there is a need for specific tools to assess the aircraft capabilities and to support delegation function. This requires a full sharing of the trajectory information between all the actors. It may be necessary to tune STCA in a specific mode for this procedure (restricted to collision avoidance only).

## 5. Human Performance

### 5.1 Human Factors Considerations

**5.1.1** Change of role of controllers and pilots need to be carefully assessed and understood by both parties however, this module is still in the research and development phase so the human factors considerations are still in the process of being identified through modelling and beta testing. Future iterations of this document will become more specific about the processes and procedures necessary to take the human factors considerations into account. There will be a particular emphasis on identifying the human-machine interface issue if there are any and providing the high risk mitigation strategies to account for them.

### 5.2 Training and Qualification Requirements

**5.2.1** Specific training and qualification are required. The pilot needs to be trained and qualified to assume the new role and responsibility and correct usage of the new procedures and avionics. Automation support is needed both for the pilot and the controller which therefore will have to be trained to the new environment and to identify the aircraft/facilities which can use the services.

### 5.3 Others

Liability issues are to be considered.

## 6. Regulatory/standardization needs and Approval Plan (Air & Ground)

- **Regulatory/Standardization:** Updates required to current published separation minima that includes:
- **Approval Plans:** To Be Determined.

## 7. Implementation and Demonstration Activities

### 7.1 Current Use

None at this time.

### 7.2 Planned or Ongoing Trials

European projects:

- **ASSTAR (2005-2007) initiated the work on [ASEP](#) and SSEP applications in Europe which has been pursued by SESAR projects as follows:**

- **SESAR Project 04.07.04.b [ASAS-ASEP](#) Oceanic Applications**

“The Airborne Separation In Trail Follow (ASEP-ITF) and In Trail Merge (ASEP-ITM) applications have been designed for use in oceanic and other non-radar airspace.

ASEP-ITF transfers responsibility for separation between the ITF Aircraft and a Reference Aircraft from the controller to the flight crew for the period of the manoeuvre. This transfer of responsibility will place high accuracy and integrity requirements on the avionics (both the ITF and Reference Aircraft positioning, airborne surveillance and ASEP-ITF ASAS logic). ASEP-ITF is intended as a means of improving vertical flexibility, allowing aircraft to make a level change where current procedural separation minima will not allow it, by enabling level changes to the flight level of a Reference Aircraft which is operating at a different flight level, but on the same identical track.

ASEP-ITM transfers responsibility for separation between the ITM Aircraft and a Reference Aircraft from the controller to the flight crew for the period of the manoeuvre. This transfer of responsibility will place high accuracy and integrity requirements on the avionics (both the ITM and Reference Aircraft positioning, airborne surveillance and ASEP-ITM ASAS logic). ASEP-ITM is intended as a means of improving lateral flexibility, allowing aircraft to change their routing where current procedural separation minima will not allow it, by enabling a lateral manoeuvre to follow, and then

maintain, a minimum interval behind a Reference Aircraft which is operating at a same direction flight level.

Both applications will require the crew to use airborne surveillance information provided on the flight deck to identify the potential opportunity to use the applications and to maintain a reduced separation from the Reference aircraft during the manoeuvres.”

- **SESAR Project 04.07.06 En Route Trajectory and Separation Management – [ASAS](#) Separation (Cooperative Separation)**

The main objective of this project is to assess the introduction of ASAS separation application in the SESAR context (taking into account all platforms, including military and UAS).

The project will be focused on the possibility to delegate in specific and defined conditions the responsibility for traffic separation tasks to the flight deck of suitable equipped aircraft.

## **8. Reference Documents**

### **8.1 Standards**

### **8.2 Procedures**

### **8.3 Guidance material**

- ICAO ANConf/11-IP/5 draft ASAS Circular (2003);
- FAA/EUROCONTROL ACTION PLAN 23 – D3 –The Operational Role of Airborne Surveillance in Separating Traffic (November 2008);
- FAA/EUROCONTROL ACTION PLAN 23 – D4 – ASAS application elements and avionics supporting functions (2010).

## Module N° B3-85: Airborne Self-Separation (SSEP):

<b>Summary</b>	Creation of operational benefits through total delegation of responsibility to the flight deck for separation provision between suitably equipped aircraft in designated airspace, thus reducing the need for conflict resolution. Benefits will include, reduced separation minima, reduction of controller workload, optimum flight trajectories and lower fuel consumption.	
<b>Main Performance Impact</b>	KPA-02 Capacity, KPA-04 Efficiency, KPA-05 Environment; KPA-06 Flexibility; KPA-08 Participation by the ATM Community; KPA-10 Safety	
<b>Operating Environment / Flight Phases</b>	En-route phase, oceanic	
<b>Applicability Considerations</b>	The safety case needs to be carefully assessed and the impact on capacity is still to be assessed, implying new regulation on airborne equipment and equipage roles and responsibilities (procedure and training). First area for SSEP application is in low density areas.	
<b>Global Concept Component(s)</b>	CM- Conflict Management	
<b>Global Plan Initiatives (GPI)</b>	GPI-16 Decision support systems and alerting systems	
<b>Main Dependencies</b>	B0-86, B2-85 and B2-101	
<b>Global Readiness Checklist</b>		<b>Status (ready or date)</b>
	Standards Readiness	Est. 2028
	Avionics Availability	Est. 2028
	Ground Systems Availability	Est. 2028
	Procedures Available	Est. 2028
	Operations Approvals	Est. 2028

### 1. Narrative

#### 1.1 General

Airborne separation is described in the Global ATM Operational concept (ICAO Doc 9854).

#### Self-Separation

Self-separation is the situation where the airspace user is the separator for its activity in respect of one or more hazards.

Full self-separation is the situation where the airspace user is the separator for its activity in respect of all hazards. In this case, no separation provision service will be involved; however, other ATM services, including strategic conflict management services, may be used.

#### 1.1.1 Baseline

The baseline is provided by the first [ASAS](#) application described in the module B0-86 In-Trail Procedures, B1-85 ASAS-ASPA interval management and B2-85 Airborne separation by temporary delegation. These ASAS- SSEP operations will be the next step, giving more autonomy to the equipped aircraft.

#### 1.1.2 Change brought by the module

This module will introduce self-separation relying on aircraft capabilities including airborne surveillance supported by ADS-B and giving responsibility for separation to the pilot in designated airspace.

**Airborne self-separation:** The flight crew ensures separation of their aircraft from all surrounding traffic. The controller has no responsibility for separation. First applications are in Oceanic airspace and low density airspace.

**Typical Airborne Self-separation applications include:**

- Airborne Self-separation in ATC-controlled airspace.
- Airborne Self-separation in segregated en-route airspace.
- Airborne Self-separation in mixed-equipage en-route airspace.
- SSEP – FFT Free Flight on an Oceanic Track

## 2. Intended Performance Operational Improvement

Metrics to determine the success of the module are proposed in the *Manual on Global Performance of the Air Navigation System (Doc 9883)*.

Capacity	Increase by allowing reduced separation minima and potential reduction of <a href="#">ATCO</a> workload, and even suppression of the tactical role of the ATS in low density airspace.
Efficiency	Optimum flight trajectories
Environment	Less fuel consumption due to more optimum flight trajectories
Flexibility	More flexibility to take in account change in constraint, weather situation
Participation by the ATM community	Increased role of the pilot
Safety	To be demonstrated

<a href="#">CBA</a>	To be determined by balancing cost of equipment and training and reduced penalties
---------------------	--

## 3. Necessary Procedures (Air & Ground)

ASAS- SSEP procedures need to be defined for PANS-ATM and PANS-OPS with the need to determine applicable separation minima. Operational procedures to enter and exit the designated airspace must be defined.

## 4. Necessary System capability (Air & Ground)

### 4.1 Avionics

For self-separation (SSEP) the main capabilities are on [ASAS](#). The ASAS is composed of three main functions, i.e. airborne surveillance, conflict detection and conflict resolution.

### 4.2 Ground systems

For self-separation in a mixed airspace where a mix of equipped and non-equipped is authorized, on ground there is a need for specific tools to assess the aircraft capabilities, to support and to monitor the execution of separation by self-separating aircraft, while managing the separation of the others aircraft. This requires a full sharing of the trajectory information between all the actors.

For self-separation in a segregated airspace, there is a need to check that the predicted density allows this mode of mitigations and that the aircraft are authorized to fly through this airspace. Specific tools could be necessary to manage the transfer from self-separation airspace to conventional airspace.

## 5. Human Performance

### 5.1 Human Factors Considerations

**5.1.1** Change of role of controllers and pilots need to be carefully assessed. Specific training and qualification are required.

### 5.2 Training and Qualification Requirements

**5.2.1** The pilot need to be trained and qualified to assume the new role and responsibility and correct usage of the new procedures and avionics. Automation support is needed for the pilot and the controller which therefore will have to be trained to the new environment and to identify the aircraft/facilities which can use the services in mixed mode environments.

### 5.3 Others

Liability issues are to be considered

## 6. Regulatory/standardization needs and Approval Plan (Air & Ground)

Regulatory/Standardization: Updates as required for enhanced exchange of flight information in:

- ICAO Doc 4444, *Procedures for Air Navigation Services — Air Traffic Management*;
- ICAO Doc 8168, *Aircraft Operations*;

FAA AC TBD, EASA AMD TBD.

## 7. Implementation and Demonstration Activities

### 7.1 Current Use

None at this time.

### 7.2 Planned or Ongoing Trials

- **ASSTAR**
- **SESAR Project 04.07.04.b**
- [ASAS-ASEP Oceanic Applications](#)

The Airborne Separation In Trail Follow (ASEP-ITF) and In Trail Merge (ASEP-ITM) applications have been designed for use in oceanic and other non-radar airspace.

ASEP-ITF transfers responsibility for separation between the ITF Aircraft and a Reference Aircraft from the controller to the flight crew for the period of the manoeuvre. This transfer of responsibility will place high accuracy and integrity requirements on the avionics (both the ITF and Reference Aircraft positioning, airborne surveillance and ASEP-ITF procedure). ASEP-ITF is intended as a means of improving vertical flexibility, allowing aircraft to make a level change where current procedural separation minima will not allow it, by enabling level changes to the flight level of a Reference Aircraft which is operating at a different flight level, but on the same identical track.

ASEP-ITM transfers responsibility for separation between the ITM Aircraft and a Reference Aircraft from the controller to the flight crew for the period of the manoeuvre. This transfer of responsibility will place high accuracy and integrity requirements on the avionics (both the ITM and Reference Aircraft positioning, airborne surveillance and [ASEP-ITM](#) procedure). ASEP-ITM is intended as a means of improving lateral flexibility, allowing aircraft to change their routing where current procedural separation minima will not allow it, by enabling a lateral manoeuvre to follow, and then maintain, a minimum spacing behind a Reference Aircraft which is operating at a same direction flight level.

Both applications will require the crew to use airborne surveillance information provided on the flight deck to identify the potential opportunity to use the applications and to maintain a reduced separation from the Reference aircraft during the manoeuvres.”



- **SESAR Project 04.07.05 Self Separation in Mixed Mode Environment**

One goal of the ASAS development path is to enable self separation (SSEP) in mixed mode operations. The intention is to allow self-separating flights and ANSP separated flights to operate in the same airspace. The project has two phases with following objectives:

1st phase: Assess compatibility between 4D-contract and ASEP applications as a step towards autonomous operations.

2nd phase: develop and validate the operating concept for the SSEP applications in mixed mode, i.e. together with conventional, new airborne mode (ASEP-C&P) and new [ANSP](#) modes.

The main objective is to validate the integration of 4D, ASAS, and conventional traffic in the separation management task. The focus will be the interaction of conventional and new separation modes and the consequences for capacity, efficiency, safety, and predictability. Moreover, relations between safety and capacity will be studied aiming at decreasing the number of critical incidents despite increasing traffic.

- **SESAR WP4.7.6 En Route Trajectory and Separation Management – [ASAS](#) Separation (Cooperative Separation)**

The main objective of this project is to assess the introduction of ASAS separation application in the SESAR context (taking into account all platforms, including military and UAS). The project will be focused on the possibility to delegate in specific and defined conditions the responsibility for traffic separation tasks to the flight deck of suitable equipped aircraft

## **8. Reference Documents**

### **8.1 Standards**

### **8.2 Procedures**

### **8.3 Guidance Materials**

- ICAO ANConf/11-IP/5 draft [ASAS](#) Circular (2003);
- FAA/EUROCONTROL ACTION PLAN 23 – D3 -The Operational Role of Airborne Surveillance in Separating Traffic (November 2008);
- FAA/EUROCONTROL ACTION PLAN 23 – D4 –ASAS application elements and avionics supporting functions (2010).

### **8.4 Approval Documents**

- ICAO Doc 4444, *Procedures for Air Navigation Services — Air Traffic Management*;
- ICAO Doc 8168, *Aircraft Operations*;
- FAA AC TBD, EASA AMD TBD.

## **Performance Improvement Area 3: Optimum Capacity and Flexible Flights – Through Global Collaborative ATM.**

***Thread: Optimum Flight Levels***

This Page Intentionally Left Blank

## Module N° B0-86: Improved Access to Optimum Flight Levels through Climb/Descent Procedures using ADS-B

<b>Summary</b>	This module enables an aircraft to reach a more satisfactory flight level for flight efficiency or to avoid turbulence for safety. The main benefit of ITP is significant fuel savings and the uplift of greater payloads	
<b>Main Performance Impact</b>	KPA-02 Capacity, KPA -04 Efficiency, KPA-05 Environment, KPA-Safety.	
<b>Operating Environment/Phases of Flight</b>	En-Route	
<b>Applicability Considerations</b>	This can be applied to routes in procedural airspaces,	
<b>Global Concept Component(s)</b>	CM, AUO, AOM	
<b>Global Plan Initiatives (GPI)</b>	GPI-9, GPI-7	
<b>Pre-Requisites</b>	NIL	
<b>Global Readiness Checklist</b>		<b>Status</b> (ready now or estimated date).
	Standards Readiness	√
	Avionics Availability	√
	Infrastructure Availability	√
	Ground Automation Availability	√
	Procedures Available	√
	Operations Approvals	√

### 1. Narrative

#### 1.1 General

The use of ITP facilitates en-route climb or descent to enable better use of optimal flight levels from a flight efficiency or safety perspective in environments where a lack of ATC surveillance and/or the large separation minima currently implemented was a limiting factor. The In Trail Procedure (ITP) is designed to enable an aircraft to climb or descend through the altitude of other aircraft when the requirements for procedural separation would not be met. The system benefits of ITP are significant fuel savings and less passenger and cabin crew injuries by leaving a turbulent altitude. This is the first airborne surveillance application to generate operational benefits through a new separation minimum.

The ability of an aircraft to climb through the altitude of another aircraft when normal separation procedures would not allow this prevents an aircraft being trapped at an unsatisfactory altitude and thus incurring non-optimal fuel burn for prolonged periods or possible injuries to cabin crew and passengers. This immediately results in reduced fuel-burn and emissions. Once the procedure has been field proven, it will also allow for a reduction in the contingency fuel carriage requirement, which in turn will result in reduced fuel-burn and emissions.

#### 1.1.1 Baseline

ITP using ADS-B became operational within the Oakland Oceanic FIR in August 2011 and hence can be considered to be a baseline.

### 1.1.2 Change brought by the module

The introduction of ITP and ADS-B based separation minima enable aircraft to climb or descend through the altitude of other aircraft when the requirements for procedural separation cannot be met. This reduces fuel-burn and emissions by allowing aircraft to overcome altitude constraints due to aircraft flying at higher or lower altitudes and fly at a more efficient altitude. ITP also provides safety benefits by providing a tool to manage contingency scenarios such as climbing out of turbulence and potentially avoiding weather. Once the procedure has been field proven, it will also allow for a reduction in the contingency fuel carriage requirement, which in turn will result in reduced fuel-burn and emissions and the uplift of greater payloads.

### 1.1.3 Other remarks

NIL

## 2. Intended Performance Operational Improvement/

**Metrics to determine the success of the module are proposed in the *Manual on Global Performance of the Air Navigation System (Doc 9883)*.**

Capacity	improvement in capacity on a given air route
Efficiency	increased efficiency on oceanic and potentially continental en-route.
Environment	reduced emissions
Safety	a reduction of possible injuries for cabin crew and passengers.

CBA	
-----	--

## 3. Necessary Procedures (Air & Ground)

Procedures for ITP using ADS-B have been developed and a PANS-ATM Amendment is in progress. Additional information will be available in an ICAO circular – “Safety Assessment for the development of Separation Minima and Procedures for In-Trail Procedure (ITP) using Automatic Dependant Surveillance – Broadcast (ADS-B) Version 1.5.4”

ITP requires the use of CPDLC as per PANS-ATM amendment for an applicability date of Nov 2013.

## 4. Necessary System Capability

### 4.1 Avionics

The aircraft performing the in-trail procedure will require an ADS-B IN capability compliant with DO-312/ED-159 or DO-317A/ED-194. The other aircraft involved in the procedure will require an ADS-B OUT capability compliant with AMC 20-24/DO-260A/DO-260B/ED-102A, or DO-317A/ED-194.

CPDLC compliant with DO-306 chg 1 / ED-122 chg 1 is required.

### 4.2 Ground Systems

It is recommended that conflict probe logics be adapted to ITP separation minimum.

## 5. Human Performance

### 5.1 Human Factors Considerations

Responsibility for separation is not modified; the controller is still responsible to ensure separation between these aircraft.

Human Factors have been taken into consideration during the development of the processes and procedures associated with this module. The human-machine interface for the automation aspects of this performance improvement have also been addressed both in terms of ergonomic considerations as well as in their practical application (see Section 6 for examples). The possibility of latent failures however, continues to exist and vigilance is requested during all implementation actions. It is further requested that human factor issues, identified during implementation, are reported to the international community through ICAO as part of any safety reporting initiative.

## 5.2 Training and Qualification Requirements

The flight crew needs to be trained and qualified to understand the limitations of the equipment and to ensure a correct usage of the In-Trail Procedure and supporting avionics. In particular, flight crews must be trained on the criticality of revalidating the ITP criteria prior to initiating an ITP climb or descent.

The controller needs to be trained and qualified to assume the tasks and to ensure a correct usage of the In-Trail Procedure and ground support tools.

## 5.3 Other

In procedural airspace where a conflict probe is provided for controller use, it is strongly recommended that such conflict probe software be adapted to the ITP separation minimum.

## 6. Regulatory/standardization needs and Approval Plan (Air and Ground)

- **Regulatory/Standardization:** Use current published criteria that includes the documents given in Section 8.4:
- **Approval Plans:** To Be Determined. Operational Approval guidance/criteria may be needed based upon regional application for ATSA.

## 7. Implementation and Demonstration Activities

### 7.1 Current Use

The EUROPEAN (ISAVIA, NATS, EUROCONTROL, AIRBUS, SAS) CRISTAL ITP trial validated the concepts for ITP.

EUROCONTROL CASCADE Pioneer project is undergoing an operational evaluation in the North Atlantic in Reykjavik and Shanwick FIR with British Airways, Delta Airlines, Swiss, US Airways, Virgin Atlantic, involving 25 Airbus and Boeing aircraft. The evaluation began on the 07-Feb-2012.

ITP is a part of trials to be undertaken under the ASPIRE programme. ASPIRE is a joint programme between AirServices Australia, the Airways Corporation of New Zealand, CAA of Singapore and the Japan Civil Aviation Bureau.

ITP is undergoing an operational evaluation (trial) in the Oakland Oceanic FIR, using 12 equipped B474-400s operated by United Airlines. This operational evaluation began on 15-Aug-2011, and is expected to last about two years.

### 7.2 Planned or Ongoing Activities

- **United States** - Trials are currently being completed to demonstrate the use of In-Trail Procedures using ADS-B In.

## 8. Reference Documents

### 8.1 Standards

- EUROCONTROL ATSAW Deployment Plan(draft)
- EUROCAE ED-159 / RTCA DO-312 "Safety, Performance and Interoperability Requirements Document for the In-Trail Procedure in Oceanic Airspace (ATSA-ITP) Application".

### 8.2 Procedures

### 8.3 Guidance Material

### 8.4 Approval Documents

- FAA AC 20-172a;
- FAA TSO-C195a;

- FAA Memo; Interim Policy and Guidance Automatic Dependent Surveillance Broadcast (ADS-B) Aircraft Surveillance Systems Supporting Oceanic In-Trail Procedures (ITP). Dated: May 10, 2010;
- DO-312/ED-159;
- DO-317A/ED-194;
- ICAO circular – “Safety Assessment for the development of Separation Minima and Procedures for In-Trail Procedure (ITP) using Automatic Dependant Surveillance – Broadcast (ADS-B) Version 1.5.4”.

This Page Intentionally Left Blank



## **Performance Improvement Area 3: Optimum Capacity and Flexible Flights – Through Global Collaborative ATM.**

***Thread: Airborne Collision Avoidance Systems***

This Page Intentionally Left Blank

## Module N° B0-101: ACAS Improvements

<b>Summary</b>	To provide short term improvements to existing airborne collision avoidance systems (ACAS) to reduce nuisance alerts while maintaining existing levels of safety. This will reduce trajectory perturbation and increase safety in cases where there is a breakdown of separation.	
<b>Main Performance Impact</b>	KPA-04 Efficiency, KPA-10 Safety	
<b>Operating Environment / Flight Phases</b>	En-route flight phases and approach flight phases.	
<b>Applicability Considerations</b>	Safety and operational benefits increase with the proportion of equipped aircraft.	
<b>Global Concept Component(s)</b>	CM – Conflict Management.	
<b>Global Plan Initiatives (GPI)</b>	GPI-2 reduced vertical separation minima GPI-9 situational awareness GPI-16 Decision support systems and alerting systems	
<b>Pre-Requisites</b>	NIL	
<b>Global Readiness Checklist</b>		<b>Status</b> (ready now or estimated date)
	Standards Readiness	√
	Avionics Availability	√
	Ground Systems Availability	N/A
	Procedures Available	√
	Operations Approvals	√

### 1. Narrative

#### 1.1 General

This module is dealing with the short term improvements to the performance of the existing airborne collision avoidance system – ACAS. ACAS is the last resort safety net for pilots. Although ACAS is independent from the means of separation provision, ACAS is part of the ATM system.

##### 1.1.1 Baseline

[ACAS](#) is subject to global mandatory carriage for aeroplanes with a MTCM greater than 5.7 tons. The current version of ACASII is 7.0.

##### 1.1.2 Change brought by the module

This module implements several optional improvements to airborne collision avoidance system in order to minimize “nuisance alerts” while maintaining existing levels of safety.

The TCAS version 7.1 introduces significant safety and operational benefits for ACAS operations.

Safety studies indicate that ACAS II reduces risk of mid-air collisions by 75 – 95% in encounters with aircraft that are equipped with either a transponder (only) or ACAS II respectively. ACAS II SARPS are aligned with RTCA/EUROCAE MOPS. The SARPs and the MOPS have been upgraded in 2009/2010 to resolve safety issues and to improve operational performance. The RTCA DO185B and EUROCAE ED143 include these improvements also known as TCAS V7.1.

The TCAS v7.1 introduces new features namely the monitoring of own aircraft’s vertical rate during a Resolution Advisory (RA) and a change in the RA annunciation from “Adjust Vertical Speed, Adjust” to “Level Off”. It was confirmed that the new version of the CAS logic would definitely bring significant safety benefits, though only if the majority of aircraft in any given airspace are properly equipped. ICAO agreed to mandate

the improved [ACAS](#) (TCAS version 7.1) for new installations as of 1/1/2014 and for all installations no later than 1/1/2017.

During a TCAS encounter, prompt and correct response to RAs is the key to achieve maximum safety benefits. Operational monitoring shows that pilots do not always follow their RA accurately (or even do not follow at all). Roughly 20% of RAs in Europe are not followed.

TCAS safety and operational performance highly depends on the airspace in which it operates. Operational monitoring of TCAS shows that unnecessary RAs can occur when aircraft approach their cleared flight level separated by 1000 ft with a high vertical rate. Roughly 50% of all RAs in Europe are issued in 1000 ft level-off geometries. ANConf.11 recognized the issue and requested to investigate automatic means to improve ATM compatibility.

In addition, two optional features can enhance [ACAS](#) performance:

- 1) Coupling TCAS and Auto-Pilot/Flight Director to ensure accurate responses to RAs either automatically or manually thanks to flight director (APFD function)
- 2) Introducing a new altitude capture law to improve TCAS compatibility with ATM (TCAP function)

## 2. Intended Performance Operational Improvement

**Metrics to determine the success of the module are proposed in the *Manual on Global Performance of the Air Navigation System (Doc 9883)*.**

<i>Efficiency</i>	<a href="#">ACAS</a> improvement will reduce unnecessary RA and then reduce trajectory perturbation
<i>Safety</i>	<a href="#">ACAS</a> increase safety, as collision avoidance system and case of failure of the separation provision.

<i>CBA</i>	TBD
------------	-----

## 3. Necessary Procedures (Air & Ground)

[ACAS](#) procedures are defined in PANS-ATM (Doc 4444) and in PANS-OPS (Doc 8168). This evolution does not change procedures.

## 4. Necessary System Capability

### 4.1 Avionics

RTCA DO185B / EUROCAE DO143 MOPS are available for TCAS implementation.

RTCA DO325 Annex C is being modified to accommodate the 2 functions (APFD and TCAP). It should be ready by Q1 2013.

### 4.2 Ground Systems

Not Applicable

## 5. Human Performance

### 5.1 Human Factors Considerations

**5.1.1** [ACAS](#) performance is influenced by human behaviour. ACAS is a last resort function implemented on aircraft with a flight crew of two pilots. The operational procedures (PANS-OPS and PANS-ATM) have been developed and refined for qualified flight crews. Airbus has been able to certify APFD function on A380 including human performance aspects.

**5.1.2** Human Factors have been taken into consideration during the development of the processes and procedures associated with this module. Where automation is to be used, the Human-Machine interface has been considered from both a functional and ergonomic perspective (See Section 6 for examples). The possibility of latent failures however, continues to exist and vigilance is requested during all implementation

actions. It is further requested that human factor issues, identified during implementation, be reported to the international community through ICAO as part of any safety reporting initiative.

## 5.2 Training and Qualification Requirements

**5.2.1** Training in the operational standards and procedures are required for this module and can be found in the links to the documents in Section 8 to this module. Likewise, the qualifications requirements are identified in the regulatory requirements in Section 6 which form an integral part to the implementation of this module. Training guidelines are described in the [ACAS](#) Manual (Doc 9863). Recurrent training is recommended.

## 6. Regulatory/standardization needs and Approval Plan (Air & Ground)

- **Regulatory/Standardization:** Use current published requirements that includes the material given in Section 8.4:
- **Approval Plans:** Must be in accordance with application requirements e.g. EASA NPA 2010-03 requirement of 1/3/2012 for new installations and 1/12/2015 for all installations, or ICAO mandate of 1/1/2014 for new installations and 1/1/2017 for all installations.

## 7. Implementation and Demonstration Activities

### 7.1 Current Use

TCAS v7.1 is already fitting new aircraft, e.g., AIRBUS A380. Operational monitoring by States and international organisations in a position to do so is recommended.

### 7.2 Planned or Ongoing Trials

Airbus has already developed, evaluated and certified APFD function on A380. Airbus has developed and evaluated TCAP function on A380. Certification is expected by the end of 2012.

SESAR project provided evidences that the two functions would bring significant operational and safety benefits in the European environment, in particular by extension to non Airbus aircraft.

- 1) TCAP: with a theoretical 100% equipage in Europe, the likelihood to receive an RA during a 1000 ft level-off encounter is divided by up to 32; for 50% equipage, the likelihood is already divided by 2 which confirms the improved compatibility with ATM.

Performance assessment in the US airspace should be conducted in 2012.

- 2) APFD: the results are expressed in risk ratios which is the key safety metric indicator for TCAS equipage. Risk ratio = (risk of collision with TCAS)/(risk of collision without TCAS): with a theoretical 100% equipage, the risk ratio is reduced from 33% (current situation) to 15.5%. With a 50% equipage the risk ratio is already reduced to 22%

## 8. Reference Documents

### 8.1 Standards

- ICAO Annex 6 — *Operation of Aircraft, Part I - International Commercial Air Transport – Aeroplanes. carriage requirements;*
- ICAO Annex 10 —. *Aeronautical Telecommunications, Volume IV - Surveillance Radar and Collision Avoidance Systems;* (Including Amendment 85- July 2010)
- EUROCAE ED-143 / RTCA DO-185B, Minimum Operational Performance Standards for Traffic Alert and Collision Avoidance System II (TCAS II);
- RTCA DO-325, Minimum Operational Performance Standards (MOPS) for Automatic Flight Guidance and Control Systems and Equipment. Appendix C estimated 2013
- RTCA DO185B / EUROCAE DO143 MOPS for TCAS implementation.

### 8.2 Procedures

- ICAO Doc 4444, *Procedures for Air Navigation Services - Air Traffic Management;*
- ICAO Doc 8168, *OPS — Aircraft Operations, Volume I — Flight Procedures.*

**8.3 Guidance Material**

- ICAO Doc 9863, *Airborne Collision Avoidance System (ACAS) Manual*.

**8.4 Approval Documents**

- FAA TSO-C119c;
- EASA ETSO-C119c;
- FAA AC120-55C;
- FAA AC20-151a;
- RTCA DO-185B, MOPS for TCAS II;
- RTCA DO-325, Appendix C, for APFD and TCAP;
- EUROCAE ED-143, MOPS for TCAS II.

## Module N° B2-101: New Collision Avoidance System

<b>Summary</b>	<p>Implementation of Airborne Collision Avoidance System (ACAS) adapted to trajectory-based operations with improved surveillance function supported by <a href="#">ADS-B</a> and adaptive collision avoidance logic aiming at reducing nuisance alerts and minimizing deviations.</p> <p>The implementation of a new airborne collision warning system will enable more efficient operations and future airspace procedures while complying with safety regulations. The new system will accurately discriminate between necessary alerts and “nuisance alerts”. This improved differentiation will lead to a reduction in controller workload as personnel will spend less time to respond to “nuisance alerts “. This will result in a reduction in the probability of a near mid-air collision.</p>	
<b>Main Performance Impact</b>	KPA-02 Capacity; KPA-10 Safety;	
<b>Operating Environment/Phases of Flight</b>	All airspaces.	
<b>Applicability Considerations</b>		
<b>Global Concept Component(s)</b>	CM - Conflict Management	
<b>Global Plan Initiatives (GPI)</b>	GPI- 2 Reduced vertical separation minima, GPI- 9 Situational awareness, GPI-16 Decision support system and alerting systems	
<b>Pre-Requisites</b>	B0-101, B1-102 and B1-85	
<b>Global Readiness Checklist</b>		<b>Status</b> (ready now or estimated date).
	Standards Readiness	Est. 2023
	Avionics Availability	Est. 2023
	Infrastructure Availability	N/A
	Ground Automation Availability	√
	Procedures Available	√
	Operations Approvals	√

### 1. Narrative

#### 1.1 General

The existing airborne collision avoidance system – ACAS II has been very effective in mitigating the risk of mid-air collisions. Safety studies indicate that ACAS II reduces risk of mid-air collisions by 75 – 95% in encounters with aircraft that are equipped with either a transponder (only) or ACAS II respectively. In order to achieve this high level of safety, however, the alerting criteria used by ACAS II often overlap with the horizontal and vertical separation associated with many safe and legal airspace procedures. ACAS II monitoring data from the U.S. indicate that as many as 90% of observed Resolution Advisories (RAs) are due to the interaction between ACAS II alerting criteria and normal ATC separation procedures (e.g., 500 feet IFR/VFR separation, visual parallel approach procedures, level-off with a high vertical rate 1,000 feet above/below IFR traffic, or VFR traffic pattern procedures). In order to achieve intended efficiencies in the future airspace, a reduction in collision avoidance alerting thresholds may be necessary in order to further reduce separation while minimizing “nuisance alerts”. Initial examination of NextGen procedures such as Closely Spaced Parallel Operations (CSPO) or use of 3 nautical mile en-route ATC separation indicate that existing ACAS performance is likely not sufficient to support these future airspace procedures. As a result, a new approach to airborne collision avoidance is necessary.

### 1.1.1 Baseline

The baseline of this module is the result of the short-term improvements to [ACAS](#) implemented with module B0-101.

### 1.1.2 Change brought by the module

Implementation of an improved airborne collision avoidance system must minimize “nuisance alerts” while maintaining existing levels of safety. Additionally, this new system must be able to more quickly adapt to changes in airspace procedures and the environment.

This successor should be capable of accommodating reduced separation minima and other new airspace procedures such as 4D trajectory management or ASAS applications, as well as the particularities of new vehicles (RPAs in particular).

Implementation of a new airborne collision avoidance system will enable more efficient operations and future airspace procedures while complying with safety regulations. The new airborne collision avoidance systems will accurately discriminating between necessary alerts and “nuisance alerts” across the expected horizontal and vertical separation projected in future airspace procedures. Improved differentiation leads to reduction in ATC personnel workload, as ATC personnel spent exert less time to respond to “nuisance alerts”.

These procedures facilitate the optimized utilization of constrained airspace, while maintain safety standards. The revision of horizontal and vertical separation enables grid-locked areas to accommodate more aircrafts in all flight domains. Augmented [ACAS](#) will facilitate Closely Spaced Parallel Operations, increasing terminal and aerodrome throughput. The new ACAS will also increase capacity of the en-route domain via the implementation of 3 nautical mile separation minima.

In addition, alerting criteria and procedures will be revisited for the new airborne collision avoidance system.

The implementation of this module depends on the on-going effort to develop a successor to the current TCAS technology.

### 1.1.3 Other remarks

The U.S. Federal Aviation Administration (FAA) has funded research and development of a new approach to airborne collision avoidance for the past 3 years. This new approach takes advantage of recent advances in dynamic programming and other computer science techniques to generate alerts using an off-line optimization of resolution advisories. This approach uses extensive actual aircraft data to generate a highly accurate dynamic model of aircraft behaviour and sensor performance. Based on a predetermined cost function and using advance computational techniques, this approach generates an optimized table of optimal actions based on information regarding intruder state information. This approach significantly reduces logic development time and effort by focusing developmental activities on developing the optimization process and not on iterative changes to pseudo-code.

## 2. Intended Performance Operational Improvement

Metrics to determine the success of the module are proposed at Doc 9883.

Key performance metrics include Probability of a Near Mid-Air Collision (p(NMAC), RA alert rate and

<i>Capacity</i>	Reduced use of the 1030/1090 MHz spectrum
<i>Safety</i>	<ul style="list-style-type: none"> <li>a. Improve Resolution Advisory (RA) rate accuracy to support future airspace procedures, such as new separation minima.                             <ul style="list-style-type: none"> <li>i. Resolution Advisory rate</li> <li>ii. Nuisance alerts rate</li> </ul> </li> <li>b. Reduction in the probability of near mid-air collision                             <ul style="list-style-type: none"> <li>i. Probability of Near Mid-Air Collision – <a href="#">P(NMAC)</a></li> </ul> </li> </ul>

## 3. Necessary Procedures (Air & Ground)

Necessary operational procedures for future [ACAS](#) are contained in PANS-OPS (ICAO Doc. 8168) and PANS-ATM (Doc 4444). Future ACAS capabilities should support the implementation of these procedures.



## 4. Necessary System Capability

### 4.1 Avionics

Improved algorithm and computational technique, as well as hybridization with [ADS-B-In](#) is needed to increase the accuracy of the RA rates and better differentiate “nuisance” and legitimate alerts. The necessary technical issues and requirements can be found in ICAO Annex 6, Part I, and [ACAS](#) Manual (ICAO Doc 9863).

### 4.2 Ground Systems

Not Applicable

## 5. Human Performance

### 5.1 Human Factors Considerations

**5.1.1** This module is still in the research and development phase so the human factors considerations are still in the process of being identified through modelling and beta testing. Future iterations of this document will become more specific about the processes and procedures necessary to take the human factors considerations into account. There will be a particular emphasis on identifying the human-machine interface issue if there are any and providing the high risk mitigation strategies to account for them.

### 5.2 Training and Qualification Requirements

**5.2.1** This module will eventually contain and number of personnel training requirements. As and when they are developed, they will be included in the documentation supporting this module and their importance signified. Likewise, any qualifications requirements that are recommended will become part of the regulatory needs prior to implementation of this performance improvement.

## 6. Regulatory/standardization needs and Approval Plan (Air and Ground)

- **Regulatory/Standardization:** Updates required for [ACAS](#) equipage and procedures to enable reduced collision avoidance thresholds in criteria includes:
  - ICAO Annex 6 — *Operation of Aircraft*, Part I — International Commercial Air Transport — Aeroplanes;
  - ICAO Annex 6 — *Operation of Aircraft*, Part II — International General Aviation — Aeroplanes;
  - ICAO Annex 10 — *Aeronautical Telecommunications*, Volume IV — Surveillance Radar and Collision Avoidance Systems;
  - ICAO Doc 4444, *Procedures for Air Navigation Services — Air Traffic Management*.
- **Approval Plans:** To Be Determined.

## 7. Implementation and Demonstration Activities

### 7.1 Current Use

TCAS is currently required for all aircrafts in the NAS. Level of equipage is dependent on the Max. Take Off Weight (MTOW) of the aircraft.

ICAO ANNEX 6 requires ACAS II for certain categories of aircraft. Currently TCAS II Version 7 is the minimum equipment specification which complies with the ACAS II standard. Some airspaces will require TCAS II Version 7.1 equipment form 2015.

### 7.2 Planned or Ongoing Activities

When installation of new [ACAS](#) is required for recommended to operators, the cost impact on operators should be taken into consideration.

US – [ACAS](#) trial is currently planned for 2012 to validate operational feasibility in PBN environment.

## 8. Reference Documents

### 8.1 Standards

- RTCA DO-298 *Safety Analysis of Proposed Change to TCAS RA Reversal Logic*.

### 8.2 Procedures

### 8.3 Guidance Material

M. J. Kochenderfer and J. P. Chryssanthacopoulos, "*Robust airborne collision avoidance through dynamic programming*," Massachusetts Institute of Technology, Lincoln Laboratory, Project Report ATC-371, 2010.

### 8.4 Approval Documents

- ICAO Annex 6 — *Operation of Aircraft*, Part I — International Commercial Air Transport — Aeroplanes;
- ICAO Annex 6 — *Operation of Aircraft*, Part II — International General Aviation — Aeroplanes;
- ICAO Annex 10 — *Aeronautical Telecommunications*, Volume IV — Surveillance Radar and Collision Avoidance Systems;
- ICAO Doc 4444, *Procedures for Air Navigation Services — Air Traffic Management*.

## **Performance Improvement Area 3: Optimum Capacity and Flexible Flights – Through Global Collaborative ATM.**

*Thread: Safety Nets*

This Page Intentionally Left Blank

## Module N°B0-102: Increased Effectiveness of Ground-Based Safety Nets

<b>Summary</b>	To monitor the operational environment during airborne phases of flight to provide timely alerts on the ground of an increased risk to flight safety. In this case Short Term Conflict Alert, Area Proximity Warnings and Minimum Safe Altitude Warnings are proposed. Ground-based safety nets make an essential contribution to safety and remain required as long as the operational concept remains human-centred.	
<b>Main Performance Impact</b>	KPA-10 Safety	
<b>Operating Environment/Phases of Flight</b>	All airborne flight phases	
<b>Applicability Considerations</b>	Benefits increase whilst traffic density and complexity increase. Not all ground-based safety nets are relevant for each environment.  Deployment of this module should be accelerated.	
<b>Global Concept Component(s)</b>	CM – Conflict Management	
<b>Global Plan Initiatives (GPI)</b>	GPI-9 Situational awareness GPI-16 Decision support and alerting systems	
<b>Main Dependencies</b>	NIL	
<b>Global Readiness Checklist</b>		<b>Status</b> (ready now or estimated date)
	Standards Readiness	<b>Not applicable</b>
	Avionics Availability	<b>Ready now</b>
	Ground Systems Availability	<b>Ready now</b>
	Procedures Available	<b>Ready now</b>
	Operations Approvals	<b>Ready now</b>

### 1. Narrative

#### 1.1 General

This module aims to implement a baseline set of ground-based safety nets. Ground-based safety nets are intended to assist the Air Traffic Controller (ATCO) in generating, in a timely manner, alerts of an increased risk to flight safety (collision, unauthorised airspace penetration and controlled flight into terrain), which may include resolution advice.

##### 1.1.1 Baseline

None

##### 1.1.2 Change brought by the module

Ground-based safety nets are functionalities of ATM systems that have the sole purpose of monitoring the environment of operations, during airborne phases of flight, in order to provide timely alerts of an increased risk to flight safety. Ground-based safety nets make an essential contribution to safety and remain required as long as the operational concept remains human-centred.

Ground-based safety nets have been in use since the 1980s. Provisions for ground-based safety nets were introduced in PANS-ATM (Doc 4444) in the early 2000s. In the mean time Ground Systems Suppliers have made ground-based safety nets part of their off-the-shelf product lines.

This module corresponds to a baseline version of the safety nets as already implemented or being implemented in many areas.

**1.2 Element 1: Short Term Conflict Alert (STCA)**

This element is intended to assist the controller, in an effective manner, in preventing collision between aircraft by generating, in a timely manner, an alert of a potential or actual infringement of separation minima. STCA must alert when the separation provision layer has been compromised but must also provide sufficient warning time to allow for corrective action, i.e. ideally avoiding that an Airborne Collision Avoidance System (ACAS) resolution advisory will be generated when the geometry of the situation permits this. In some environments this necessitates the use of separation minima in STCA that are significantly lower than the separation minima used in the separation provision layer. STCA is only effective when each alert causes the controller to immediately assess the situation and if necessary take appropriate action.

Compatibility between [ACAS](#) and STCA has to be ensured through the procedures

**1.3 Element 2: Area Proximity Warning (APW)**

This element is intended to warn the controller, in an effective manner, about unauthorised penetration of an airspace volume by generating, in a timely manner, an alert of a potential or actual infringement of the required spacing to that airspace volume. APW can be used to protect static, fixed airspace volumes (e.g. danger areas) but increasingly also dynamic, modular airspace volumes to enable flexible use of airspace.

**1.4 Element 3: Minimum Safe Altitude Warning (MSAW)**

This element is intended to warn the controller, in an effective manner, about increased risk of controlled flight into terrain accidents by generating, in a timely manner, an alert of aircraft proximity to terrain or obstacles. MSAW is only effective when each alert causes the controller to immediately assess the situation and if necessary take appropriate action.

**2. Intended Performance Operational Improvement/Metric to determine success**

<i>Safety</i>	Significant reduction of the number of major incidents.
<a href="#">CBA</a>	The business case for this element is entirely made around safety and the application of ALARP (As Low As Reasonably Practicable) in risk management.

**3. Necessary Procedures (Air & Ground)**

The relevant PANS-ATM (Doc 4444) provisions exist. In addition they must regularly analyse the data and circumstances pertaining to each alert in order to identify and correct any shortcomings pertaining to ground-based safety nets, airspace design and [ATC](#) procedures.

**4. Necessary System Capability**

**4.1 Avionics**

Aircraft should support cooperative surveillance using existing technology such as Mode C/S transponder or ADS-B Out.

**4.2 Ground Systems**

ATS Units providing surveillance services must be equipped with the ground-based safety nets that are appropriate and optimized for their environment.

“Appropriate off-line tools should be available to support the analysis of every safety alerts.”

## 5. Human Performance

### 5.1 Human Factors Considerations

The generated alerts should normally be appropriate and timely, and the controller should understand under which circumstances interactions can occur with normal control practices or airborne safety nets.

The two main issues from human performance are related to nuisance alerts which should be kept to a minimum and warning time for a genuine alert which should be high enough to support the completion of the procedure.

The use of ground-based safety nets will depend on the controller's trust. Trust is a result of many factors such as reliability and transparency. Neither mistrust nor complacency is desirable; training and experience is needed to develop trust at the appropriate level.

### 5.2 Training and Qualification Requirements

Controllers must receive specific ground-based safety nets training and be assessed as competent for the use of the relevant ground-based safety nets and recovery techniques.

### 5.3 Others

Nil

## 6. Regulatory/standardization needs and Approval Plan (Air & Ground)

Nil

## 7. Implementation and Demonstration Activities

### 7.1 Current Use

Worldwide, most units that provide surveillance services and that are using recent surveillance systems are already equipped with ground-based safety nets that are in principle fit for purpose. However, in many cases there is a lack of expertise, lack of tools or conflicting priorities for limited resources that cause these ground-based safety nets not being effective.

### 7.2 Planned or Ongoing Trials

No general validation required.

## 8. Reference Documents

### 8.1 Standards

- EUROCONTROL Specifications for STCA, APW, MSAW and APM, available at <http://www.EUROCONTROL.int/safety-nets>

### 8.2 Procedures

- PANS-ATM (Doc 4444), section 15.7.2 and 15.7.4

### 8.3 Guidance Material

- EUROCONTROL Guidance Material for STCA, APW, MSAW and APM, available at <http://www.EUROCONTROL.int/safety-nets>

### 8.4 Approval Documents

This Page Intentionally Left Blank



## Module N°B1-102: Ground-based Safety Nets on Approach

<b>Summary</b>	To enhance safety by reducing the risk of controlled flight into terrain accidents on final approach through the use of Approach Path Monitor (APM). APM warns the controller of increased risk of controlled flight into terrain during final approach. The major benefit is a significant reduction of the number of major incidents.	
<b>Main Performance Impact</b>	<b>KPA-10 Safety</b>	
<b>Operating Environment/Phases of Flight</b>	Approach	
<b>Applicability Considerations</b>		
<b>Global Concept Component(s)</b>	CM – Conflict Management	
<b>Global Plan Initiatives (GPI)</b>	GPI-9 Situational awareness GPI-16 Decision support and alerting systems	
<b>Main Dependencies</b>	B0-102	
<b>Global Readiness Checklist</b>		<b>Status</b> (ready now or estimated date)
	Standards Readiness	<b>Not applicable</b>
	Avionics Availability	<b>Ready now</b>
	Ground Systems Availability	<b>Est. 2014</b>
	Procedures Available	<b>Est. 2014</b>
	Operations Approvals	<b>Est. 2014</b>

### 1. Narrative

#### 1.1 General

This module aims to significantly increase the effectiveness of ground-based safety nets.

##### 1.1.1 Baseline

The baseline is provided by module B0-102. However, it may be possible to implement as a single package the baseline and the improvements brought by this module.

##### 1.1.2 Change brought by the module

This module adds an Approach Path Monitor (APM) to the safety nets provided in Module B0-102. APM warns the controller about increased risk of controlled flight into terrain accidents by generating, in a timely manner, an alert of aircraft proximity to terrain or obstacles during final approach.

This module proposed and optimized APM which keeps the number of nuisance and false alerts to an effective minimum through the use of an accurate approach path model.

### 2. Intended Performance Operational Improvement/Metric to determine success

<i>Safety</i>	Significant reduction of the number of major incidents.
<a href="#">CBA</a>	The business case for this element is entirely made around safety and the application of ALARP (As Low As Reasonably Practicable) in risk management.

### 3. Necessary Procedures (Air & Ground)

The relevant PANS-ATM (Doc 4444) provisions need to be reviewed and complemented.

### 4. Necessary System Capability

#### 4.1 Avionics

Aircraft should support cooperative surveillance using existing technology such as Mode C/S transponder or [ADS-B](#) Out. Consideration should be extended to include all air vehicles (manned and unmanned) that will be operating within or close to the confines of controlled airspace.

#### 4.2 Ground Systems

Where appropriate a functionality providing approach path monitoring should be added to the ATS unit system. The off-line safety alerts tool should be updated to cater for this new type of alerts.

### 5. Human Performance

#### 5.1 Human Factors Considerations

The generated alerts should normally be appropriate and timely, and the controller should understand under which circumstances interactions can occur with normal control practices or airborne safety nets.

The two main issues from human performance are related to nuisance alerts which should be kept to a minimum and warning time for a genuine alert which should be high enough to support the completion of the procedure.

The use of ground-based safety nets will depend on the controller's trust. Trust is a result of many factors such as reliability and transparency. Neither mistrust nor complacency is desirable; training and experience is needed to develop trust at the appropriate level.

#### 5.2 Training and Qualification Requirements

Controllers must receive specific ground-based safety nets training and be assessed as competent for the use of the relevant ground-based safety nets and recovery techniques.

#### 5.3 Others

Nil

### 6. Regulatory/standardization needs and Approval Plan (Air & Ground)

Nil

### 7. Implementation and Demonstration Activities

#### 7.1 Current Use

Nil..

#### 7.2 Planned or Ongoing Trials

- EUROPE: The SESAR programme is developing enhancements to ground-based safety nets such as multi-hypothesis algorithms and use of downlinked aircraft parameters. Ongoing trials of enhanced functionalities commenced in 2011

### 8. Reference Documents

#### 8.1 Standards

- EUROCONTROL Specifications for STCA, APW, MSAW and APM, available at <http://www.EUROCONTROL.int/safety-nets> (to be complemented)

**8.2 Procedures**

- ICAO Doc 4444, *Procedures for Air Navigation Services — Air Traffic Management*, Section 15.7.2 and 15.7.4 (to be reviewed and complemented).

**8.3 Guidance Material**

- EUROCONTROL Guidance Material for STCA, APW, MSAW and APM, available at <http://www.EUROCONTROL.int/safety-nets> (to be complemented);
- ICAO Manual for Ground-based Safety Nets (to be developed).

**8.4 Approval Documents**

This Page Intentionally Left Blank

## **Performance Improvement Area 4: Efficient Flight Path – Through Trajectory-based Operations.**

***Thread: Continuous Descent Operations***

This Page Intentionally Left Blank

## Module N° B0-05: Improved Flexibility and Efficiency in Descent Profiles (CDOs)

<b>Summary</b>	To use performance-based airspace and arrival procedures allowing aircraft to fly their optimum profile using continuous descent operations (CDOs). This will optimize throughput, allow fuel efficient descent profiles and increase capacity in terminal areas.	
<b>Main Performance Impact</b>	KPA-04 – Efficiency; KPA_05 Environment; KPA-09 – Predictability; KPA-10 Safety	
<b>Operating Environment/Phases of Flight</b>	Approach/Arrivals and En-Route.	
<b>Applicability Considerations</b>	<p>Regions, States or individual locations most in need of these improvements. For simplicity and implementation success, complexity can be divided into three tiers:</p> <ol style="list-style-type: none"> <li>1. Least Complex – Regional/States/Locations with some foundational PBN operational experience that could capitalize on near term enhancements, which include integrating procedures and optimizing performance.</li> <li>2. More Complex – Regional/States/Locations that may or may not possess <a href="#">PBN</a> experience, but would benefit from introducing new or enhanced procedures. However, many of these locations may have environmental and operational challenges that will add to the complexities of procedure development and implementation.</li> <li>3. Most Complex – Regional/States/Locations in this tier will be the most challenging and complex to introduce integrated and optimized PBN operations. Traffic volume and airspace constraints are added complexities that must be confronted. Operational changes to these areas can have a profound effect on the entire State, Region or location.</li> </ol>	
<b>Global Concept Component(s)</b>	AOM – Airspace Organisation and Management AO – Aerodrome Operations TS – Traffic Synchronization, AOM	
<b>Global Plan Initiatives (GPI)</b>	GPI-10- Terminal Area Design and Management; GPI-11- RNP and RNAV Standard instrument Departures (SIDS)and Standard Terminal Arrivals (STARS);	
<b>Pre-Requisites</b>	NIL	
<b>Global Readiness Checklist</b>		<b>Status</b> (ready now or estimated date).
	Standards Readiness	√
	Avionics Availability	√
	Ground System Availability	√
	Procedures Available	√
Operations Approvals	√	

### 1. Narrative

#### 1.1 General

This module integrates with other airspace and procedures (CDO, PBN and Airspace Management) to increase efficiency, safety, access and predictability.

As traffic demand increases, the challenges in terminal areas centre around volume, convective weather, reduced-visibility conditions, adjacent airports and special activity airspace in close proximity whose procedures utilize the same airspace, and policies that limit capacity, throughput, and efficiency.

Traffic flow and loading (across ingress and egress routes) are not always well-metered, balanced or predictable. Obstacle and airspace avoidance (in the form of separation minima and criteria), noise

abatement procedures, as well as wake encounter risk mitigation, tend to result in operational inefficiencies (e.g., added time or distance flown, thus more fuel).

Inefficient routing can also cause under-use of available airfield and airspace capacity. Finally, challenges are presented to States by serving multiple customers (international and domestic with various capabilities): the intermingling of commercial, business, general aviation and many times military traffic destined to airports within a terminal area that interact and at times inhibit each other's operations.

### 1.1.1 Baseline

The baseline for this module may vary from one State, Region or location to the next. Noted is the fact that some aspects of the movement to PBN have already been the subject of local improvements in many areas; these areas and users are already realizing benefits.

The lack of an ICAO PBN operational approval guidance material is slowing down implementation and is perceived as one of the main roadblocks for harmonization.

There is still some work to be done to harmonize PBN nomenclature, especially in charts and States/Regional regulations (e.g. most of European regulations still mention [B-RNAV](#) and [P-RNAV](#)).

### 1.1.2 Change brought by the module

Flight operations in many terminal areas precipitate the majority of current airspace delays in many states. Opportunities to optimize throughput, improve flexibility, enable fuel-efficient climb and descent profiles, and increase capacity at the most congested areas should be a high-priority initiative in the near-term.

The core capabilities that should be leveraged are RNAV; RNP where needed; continuous descent operations (CDO); where possible, increased efficiencies in terminal separation rules in airspace; effective airspace design and classification; ATC flow and ATC co-operative surveillance (radar or [ADS-B](#)). Opportunities to reduce emissions and aircraft noise impacts should also be leveraged where possible.

## 1.2 *Element 1: Continuous Descent Operations*

Continuous Descent is one of several tools available to aircraft operators and ANSPs to benefit from existing aircraft capabilities and reduce noise, fuel burn and the emission of greenhouse gases. Over the years, different route models have been developed to facilitate CDO and several attempts have been made to strike a balance between the ideal of environmentally friendly procedures and the requirements of a specific airport or airspace.

Future developments in this field are expected to allow different means of realizing the performance potential of CDO without compromising the optimal Airport Arrival Rate (AAR).

CDO is enabled by airspace design, procedure design and facilitation by ATC, in which an arriving aircraft descends continuously, to the greatest possible extent, by employing minimum engine thrust, ideally in a low drag configuration, prior to the final approach fix/final approach point (FAF/FAP). An optimum CDO starts from the top-of-descent (TOD) and uses descent profiles that reduce controller-pilot communications and segments of level flight.

Furthermore it provides for a reduction in noise, fuel burn and emissions, while increasing flight stability and the predictability of flight path to both controllers and pilots.

## 1.3 *Element 2: Performance-based Navigation*

Performance-based navigation (PBN) is a global set of area navigation standards, defined by ICAO, based on performance requirements for aircraft navigating on departure, arrival, approach or en-route.

These performance requirements are expressed as navigation specifications in terms of accuracy, integrity, continuity, availability and functionality required for a particular airspace or airport.

PBN will eliminate the regional differences of various Required Navigation Performance (RNP) and Area Navigation (RNAV) specifications that exist today. The PBN concept encompasses two types of navigation specifications:

- RNAV specification: navigation specification based on area navigation that does not include the requirement for on-board performance monitoring and alerting, designated by the prefix RNAV, e.g. RNAV 5, RNAV 1.



- RNP specification: navigation specification based on area navigation that includes the requirement for on-board performance monitoring and alerting, designated by the prefix RNP, e.g. RNP 4.

**2. Intended Performance Operational Improvement**

Metrics to determine the success of the module are proposed in the *Manual on Global Performance of the Air Navigation System (Doc 9883)*.

<i>Efficiency</i>	<ul style="list-style-type: none"> <li>a. cost savings and environmental benefits through reduced fuel burn</li> <li>b. authorization of operations where noise limitations would otherwise result in operations being curtailed or restricted</li> <li>c. reduction in the number of required radio transmissions</li> <li>d. optimal management of the top-of-descent in the en-route airspace</li> </ul>
<i>Environment</i>	As per efficiency
<i>Predicability</i>	<ul style="list-style-type: none"> <li>a. More consistent flight paths and stabilized approach paths</li> <li>b. Less need for vectors</li> </ul>
<i>Safety</i>	<ul style="list-style-type: none"> <li>a. more consistent flight paths and stabilized approach paths</li> <li>b. reduction in the incidence of controlled flight into terrain (CFIT)</li> <li>c. separation with the surrounding traffic (especially free-routing)</li> <li>d. reduction in the number of conflicts.</li> </ul>

<u>CBA</u>	<p>The following savings are an example of potential savings as a result of <u>CDO</u> implementation. <i>It is important to consider that CDO benefits are heavily dependent on each specific ATM environment.</i></p> <p>Nevertheless, if implemented within the ICAO CDO manual framework, it is envisaged that the benefit/cost ratio (BCR) will be positive.</p> <p>Example of savings after CDO implementation in Los Angeles TMA (KLAX)</p> <ul style="list-style-type: none"> <li>• CDOs RIIVR2/SEAVU2/OLDEE1 &amp; 4 ILS'             <ul style="list-style-type: none"> <li>○ Implemented September 25, 2008, and in use full time at KLAX.</li> </ul> </li> <li>• About 300-400 aircraft per day fly RIIVR2/SEAVU2/OLDEE1 STARs representing approximately half of all jet arrivals into KLAX             <ul style="list-style-type: none"> <li>○ 50% reduction in radio transmissions.</li> </ul> </li> <li>• Significant fuel savings – average 125 pounds per flight.             <ul style="list-style-type: none"> <li>○ 300 flights/day * 125 pounds per flight * 365 days = 13.7 million pounds/year</li> <li>○ More than 2 million gallons/year saved = more than 41 million pounds of CO2 emission avoided.</li> </ul> </li> </ul> <p>The advantage of <u>PBN</u> to the <u>ANSP</u> is that PBN avoids the need to purchase and deploy navigation aids for each new route or instrument procedure. The advantage to everyone is that PBN clarifies how area navigation systems are used and facilitates the operational approval process for operators by providing a limited set of navigation specifications intended for global use.</p> <p>The safety benefits to PBN are significant, as even airports located in the poorest areas of the world can have runway aligned approaches with horizontal and vertical guidance to any runway end without having to install, calibrate and monitor expensive ground based navigation aids. Therefore, with PBN all airports can have a stabilized instrument approach that will allow aircraft to land into the wind, as opposed to a tail wind landing.</p>
------------	---

### 3. Necessary Procedures (Air & Ground)

The ICAO Continuous Descent Operations (CDO) Manual (ICAO Document 9931) provides guidance on the airspace design, instrument flight procedures, [ATC](#) facilitation and flight techniques necessary to enable continuous descent profiles.

It therefore provides background and implementation guidance for:

- a) air navigation service providers;
- b) aircraft operators;
- c) airport operators; and
- d) aviation regulators.

The ICAO Performance-based Navigation Manual (ICAO Document 9613) provides general guidance on PBN implementation.

This manual identifies the relationship between RNAV and RNP applications and the advantages and limitations of choosing one or the other as the navigation requirement for an airspace concept.

It also aims at providing practical guidance to States, air navigation service providers and airspace users on how to implement RNAV and RNP applications, and how to ensure that the performance requirements are appropriate for the planned application.

The management of the top-of-descent (TOD) with CDO in en-route airspace (especially in the context of free-routing) will have to be analyzed because CDO will imply an imposed TOD.

### 4. Necessary System Capability

#### 4.1 Avionics

CDO is an aircraft operating technique aided by appropriate airspace and procedure design and appropriate ATC clearances enabling the execution of a flight profile optimized to the operating capability of the aircraft, with low engine thrust settings and, where possible, a low drag configuration, thereby reducing fuel burn and emissions during descent.

The optimum vertical profile takes the form of a continuously descending path, with a minimum of level flight segments only as needed to decelerate and configure the aircraft or to establish on a landing guidance system (e.g. ILS).

The optimum vertical path angle will vary depending on the type of aircraft, its actual weight, the wind, air temperature, atmospheric pressure, icing conditions and other dynamic considerations.

A [CDO](#) can be flown with or without the support of a computer-generated vertical flight path (i.e. the vertical navigation (VNAV) function of the flight management system (FMS)) and with or without a fixed lateral path. However, the maximum benefit for an individual flight is achieved by keeping the aircraft as high as possible until it reaches the optimum descent point. This is most readily determined by the onboard FMS.

#### 4.2 Ground Systems

Within an airspace concept, PBN requirements will be affected by the communication, surveillance and ATM environments, the navaid infrastructure, and the functional and operational capabilities needed to meet the ATM application.

PBN performance requirements also depend on what reversionary, non-RNAV means of navigation are available and what degree of redundancy is required to ensure adequate continuity of functions. Ground automation needs initially little changes to support CDO: potentially a flag on the display. For better integration the ground trajectory calculation function will need to be upgraded.

## 5. Human Performance

### 5.1 Human Factors Considerations

**5.1.1** The decision to plan for RNAV or RNP has to be decided on a case by case basis in consultation with the airspace user. Some areas need only a simple RNAV to maximize the benefits, while other areas such as nearby steep terrain or dense air traffic may require the most stringent RNP.

**5.1.2** Human Factors have been taken into consideration during the development of the processes and procedures associated with this module. Where automation is to be used, the Human-Machine interface has been considered from both a functional and ergonomic perspective (See Section 6 for examples). The possibility of latent failures however, continues to exist and vigilance is requested during all implementation actions. It is further requested that human factor issues, identified during implementation, are reported to the international community through ICAO as part of any safety reporting initiative.

### 5.2 Training and Qualification Requirements

**5.2.1** Since RNP AR Approaches also require significant training, ANSPs should work closely with airlines to determine where RNP AR Approach should be implemented. In all cases PBN implementation needs to be an agreement between the airspace user, the ANSP and the regulatory authorities.

**5.2.2** Training in the operational standards and procedures are required for this module and can be found in the links to the documents in Section 8 to this module. Likewise, the qualifications requirements are identified in the regulatory requirements in Section 6 which form an integral part to the implementation of this module.

## 6. Regulatory/standardization needs and Approval Plan (Air and Ground)

- **Regulatory/Standardization:** Use current published requirements that includes the material given in Section 8.4.
- **Approval Plans:** Must be in accordance with application requirements e.g. airspace design, air traffic operations, PBN requirements for fixed radius transitions, radius-to-fix legs, Required Time of Arrival (RTA), parallel offset, etc

**Discussion:** Understanding the policy context is important for making the case for local [CDO](#) implementation and ensuring high levels of participation. CDO may be a strategic objective at international, State, or local level, and as such, may trigger a review of airspace structure.

For example, noise contour production may already assume a 3-degree continuous descent final approach. Thus, even if noise performance is improved in some areas around the airport, it may not affect existing noise contours. Similarly, CDO may not affect flight performance within the area of the most significant noise contours, i.e., those depicting noise levels upon which decision-making is based.

In addition to a safety assessment, a transparent assessment of the impact of CDO on other air traffic operations and the environment should be developed and made available to all interested parties.

As PBN implementation progresses, standardized international requirements should be set for fixed radius transitions, radius-to-fix legs, Required Time of Arrival (RTA), parallel offset, VNAV, 4D control, [ADS-B](#), datalink, etc.

SMS must be part of any development process, and each one manifests itself differently for each of the PBN processes. For production development, SMS should be addressed through an ISO 9000-compliant production process, workflow, automation improvements, and data management. The production process is monitored for defect control and workflow. For air traffic developed procedures, a Safety Risk Management Document (SRMD) may be required for every new or amended procedure. That requirement will extend the time required to implement new procedures, especially PBN-based flight procedures.

Progress should be measured against the key performance indicators recommended by the Working Group(s), as approved. PBN does not:

1. add new navigation philosophy, but just is a pragmatic tool to implement navigation procedures for aircraft capability that exists for more than 30 years!
2. require States to completely overhaul navigation infrastructure, but can be implemented step-by-step

3. require States to implement the most advanced nav. spec, only needs to accommodate the operational needs

## **7. Implementation and Demonstration Activities**

### **7.1 Current Use**

#### **7.1.1 Continuous Descent Operations**

- *United States – Optimized Profile Descents (OPD) are currently implemented at KLAX, KCLT, KMSP, KPHX, and KLAS*

#### **7.1.2 Performance-based Navigation**

- *United States – New procedures are currently being developed for Metroplexes in the US to incorporate Performance-based Navigation elements such as curved paths into operations. Completion of procedure development for North Texas and Washington DC Metroplex will occur in 2013. Implementation for these two sites will occur in 2014-2015.*

### **7.2 Planned or Ongoing Activities**

#### **7.2.1 Continuous Descent Operations**

- **United States** – New procedures are currently being developed for KDEN, KSEA, and the Chicago airspace which will incorporate OPDs. Expected completion date of 2014.

#### **7.2.2 Performance-based Navigation**

- **United States** – Trials are planned in 2014-2015 to validate the feasibility of RNP Established Procedures. RNP Established will use RNP Technology to safely direct aircraft to simultaneous independent and dependent parallel approach paths with no required vertical separation with aircraft on adjacent approaches.

## **8. Reference Documents**

### **8.1 Standards**

For flight plan requirements in Amendment 1, ICAO Document 4444; PANS/ATM v15

### **8.2 Procedures**

### **8.3 Guidance Material**

- ICAO Doc 9613, *Performance-based Navigation (PBN) Manual*; ICAO Doc 9931, *Continuous Descent Operations (CDO) Manual*;
- FAA Advisory Circular, AC 90-105, Approval Guidance for RNP Operations and Barometric Vertical Navigation in the U.S. National Airspace System) which provides system and operational approval guidance for operators (only reflects the US situation).

### **8.4 Approval Documents**

- ICAO Doc 9931, *Continuous Descent Operations Manual*;
- ICAO Doc 9613, *Performance Based Navigation Manual*;
- FAA AC120-108, CDFA.

## Module N° B1-05: Improved Flexibility and Efficiency in Descent Profiles (OPDs)

<b>Summary</b>	To enhance vertical flight path precision during descent, arrival, and while in the non-precision environment and enables aircraft to fly an approach procedure not reliant on ground based equipment for vertical guidance. The main benefit is higher utilization of airports and runways lacking vertical approach guidance.	
<b>Main Performance Impact</b>	KPA-02 Capacity, KPA-04 Efficiency, KPA-06 Predictability, KPA-10 Safety	
<b>Operating Environment/Phases of Flight</b>	Descent, Arrival, Flight in Terminal Area	
<b>Applicability Considerations</b>		
<b>Global Concept Component(s)</b>	Airspace Organization and Management (AOM) Demand and Capacity Balancing (DCB) Airspace User Operations (AUO) Aerodrome operations (AO) Traffic synchronization (TS) Conflict management (CM)	
<b>Global Plan Initiatives (GPI)</b>	GPI-2 Reduced vertical separation minima GPI-5 RNAV and RNP (Performance-Based Navigation) GPI-9 Situational Awareness	
<b>Pre-Requisites</b>	B0-05	
<b>Global Readiness Checklist</b>		<b>Status</b> (ready now or estimated date).
	Standards Readiness	2018
	Avionics Availability	√
	Ground System Availability	2018
	Procedures Available	√
	Operations Approvals	2018

### 1. Narrative

#### 1.1 General

RNP with VNAV is an altimetry-based capability which enables an equipped aircraft to precisely descend on a vertical path, as computed by the Flight Management Computer (FMC), within a tolerance set in feet, while providing the flight crew with navigation performance information through avionics monitoring and alerting. The system defaults to an initial tolerance set by the individual operator, but a crew may select a new tolerance (e.g., 75 feet in the terminal area.) It is similar to lateral containment of RNP, but in the vertical plane.

##### 1.1.1 Baseline

The baseline for this block is Improved Flight Descent Profile enabled by Block B0-5. This block is a component of Trajectory-Based Operations (TBO).

##### 1.1.2 Change brought by the module

Vertical RNP contributes to Terminal airspace design and efficiency due to an aircraft's ability to maintain a vertical path during descent thus enabling vertical corridors for ingressing and egressing traffic. Other

benefits include reduced aircraft level-offs, enhanced vertical precision in the terminal airspace, de-confliction of arrival and departure procedures and adjacent airport traffic flows, and the ability of an aircraft to fly an approach procedure not reliant upon ground based equipment for vertical navigation. This ultimately leads to higher utilization of airports and runways lacking vertical approach guidance.

## 2. Intended Performance Operational Improvement

**Metrics to determine the success of the module are proposed in the *Manual on Global Performance of the Air Navigation System (Doc 9883)*.**

<i>Capacity</i>	Vertical RNP allows for precision flight in a non precision environment. This capability allows for the potential to expand the applications of standard terminal arrival and departure procedures for improved capacity and throughput, and improve the implementation of precision approaches.
<i>Efficiency</i>	Enabling an aircraft to maintain a vertical path during descent allows for vertical corridors for ingressing and egressing traffic thus increasing the efficiency of the airspace. Additionally, Vertical RNP promotes the efficient use of airspace through the ability for aircraft to fly a more precisely constrained descent profile allowing the potential for further reduced separation and increased capacity.
<i>Predictability</i>	Vertical RNP allows for enhanced predictability of flight paths which leads to better planning of flights and flows.
<i>Safety</i>	Precise altitude tracking along a vertical descent path leads to improvements in overall system safety.

<u><a href="#">CBA</a></u>	<p>Safety Enhancement: Flying more precise vertical profiles</p> <p>Efficiency: Vertical RNP contributes to Terminal airspace efficiency by enabling an aircraft to maintain a vertical path during descent. This allows for vertical corridors for ingressing and egressing traffic which makes the airspace more efficient. Vertical RNP will also lay the foundation for expanded use of Optimized and Continuous Descent Profiles</p> <p>Economic: Vertical RNP allows for reduced aircraft level-offs, resulting in fuel and time savings.</p>
----------------------------	---

## 3. Necessary Procedures (Air & Ground)

Flight crews require training in the proper use of the Vertical RNP functions of the FMC. Standard procedures guide the flight crews on which altitude tolerances may be selected for a particular phase of flight.

New arrival procedures and instructions used by the Ground are required for a maximum use of this capability.

## 4. Necessary System Capability

### 4.1 Avionics

[Baro-VNAV](#) capability is contained within the Flight Management Computer.

### 4.2 Ground Systems

Controllers would benefit from some automation support to display aircraft capabilities in order to know which aircraft can support OPDs.

## 5. Human Performance

### 5.1 Human Factors Considerations

5.1.1 The identification of Human Factors considerations is an important enabler in identifying processes and procedures for this module. In particular, the human-machine interface for the automation aspects of this performance improvement will need to be considered and where necessary accompanied by mitigation risk mitigation strategies such as training, education and redundancy.

### 5.2 Training and Qualification Requirements

5.2.1 Training in the operational standards and procedures will be identified along with the standards and recommended practices necessary for this module to be implemented. Likewise the qualifications requirements will be identified and included in the regulatory readiness aspects of this module when they become available.

## 6. Regulatory/standardization needs and Approval Plan (Air and Ground)

- **Regulatory/Standardization:** Use current published requirements that includes the material given in Section 8.4.
- **Approval Plans:** Must be in accordance with application requirements e.g. operations and procedures that necessitate vertical performance and guidance.

Discussion: Vertical RNP availability is better than 99.9%/hour for a single FMC installation. From an equipment certification standpoint, the loss of function is probable. Redundant equipment installation supports improbable loss of function, where required.

## 7. Implementation and Demonstration Activities

### 7.1 Current Use

RNP with Vertical Containment is currently being used on Boeing aircraft during the descent phase of flight.

### 7.2 Planned or Ongoing Activities

- US – Vertical RNP was demonstrated as part of 4D [FMS](#) trials in 2011.
- **SESAR:** Trials on advance Continuous Descend Operations (CDOs) and integration of initial 4D with continuous descend approach procedures and Arrival Management in 2012-2013 timeframe.

## 8. Reference Documents

### 8.1 Standards

- EUROCAE ED-75B, [MASPS](#) Required Navigation Performance for Area Navigation;
- RTCA DO-236B, Minimum Aviation System Performance Standards: Required Navigation Performance for Area Navigation;
- Boeing Document D6-39067-3, RNP Capability of FMC Equipped 737, Generation 3;
- Boeing Document D243W018-13 Rev D, 777 RNP Navigation Capabilities, Generation 1.

### 8.2 Procedures

### 8.3 Guidance Material

### 8.4 Approval Documents

- FAA AC20-138;
- EASA AMC20-27.

This Page Intentionally Left Blank



## Module N° B2-05: Optimized Arrivals in Dense Airspace

<b>Summary</b>	Optimized arrivals may include Optimized Profile Descents (OPDs) and Continuous Descent Arrivals (CDAs). A key emphasis is on the use of arrival procedures that allow the aircraft to apply little or no throttle in areas where traffic levels would otherwise prohibit this operation. This block will consider airspace complexity, air traffic workload, and procedure design to enable Optimized Arrivals in dense airspace.	
<b>Main Performance Impact</b>	KPA-02 Capacity; KPA-04 Efficiency; KPA-05 Environment; KPA-06 Flexibility; KPA-10 Safety.	
<b>Operating Environment/Phases of Flight</b>	En-route, Terminal Area (Landings), Descent	
<b>Applicability Considerations</b>	Global, High Density Airspace (based on US FAA Procedures)	
<b>Global Concept Component(s)</b>	Airspace Organization and Management (AOM) Airspace User Operations (AUO) Traffic synchronization (TS)	
<b>Global Plan Initiatives (GPI)</b>	GPI-5 RNAV and RNP (Performance-based navigation) GPI-9 Situational Awareness GPI-11 RNP and RNAV SIDs and STARs	
<b>Pre-Requisites</b>	B1-05, B0-20, B1-40	
<b>Global Readiness Checklist</b>		<b>Status</b> (ready now or estimated date)
	Standards Readiness	√
	Avionics Availability	2023
	Ground Systems Availability	2023
	Procedures Available	2023
	Operations Approvals	2023

### 1. Narrative

#### 1.1 General

Optimized Arrivals in Dense Airspace integrates capabilities that will provide improved use continuously descending arrivals in highest congested airspace. Key aspects of Optimized Profiles in Dense Airspace are:

- Arrival procedures which allow the aircraft to fly a “best economy descent” from en-route airspace to final approach.
- Limited or no throttle is applied throughout the descent, with momentary level-offs being used to slow an aircraft as required by airspace restrictions.
- Flow management automation that allows air traffic control to manage aircraft flying Optimized arrivals with crossing, departing, and other arriving traffic.
- Cockpit automation that allows aircraft to freely choose top-of-descent and descent profile based on aircraft state and weather conditions.
- En-route and terminal controllers rely on automation to identify conflicts and eventually propose resolutions.
- Area Navigation (RNAV) operations remove the requirement for routes to be defined by the location of navigational aids, enabling the flexibility of point-to-point aircraft operations.
- Required Navigation Performance (RNP) operations introduce the requirement for onboard performance monitoring and altering. A critical characteristic of RNP operations is the ability of the aircraft navigation system to monitor its achieved navigation performance for a specific operation, and inform the air crew if the operational requirement is being met.

- The basis for the operation is an accurate three-dimensional trajectory that is shared among aviation system users. This provides accurate latitude, longitude, and altitude information to airspace users.
- Consistent and up-to-date information describing flights and air traffic flows are available system-wide, supporting both user and service provider operations.

**1.1.1 Baseline**

The baseline for this module is Improved Flight Descent Profile and Complexity Management enabled by modules B1-05, B1-35 and B1-10. Optimized Arrivals are a component of Trajectory-Based Operations (TBO) initiatives. Decision support capabilities are available that are integrated to assist aircraft crew and air traffic separation providers in making better decisions and optimizing the arrival profile. Consistent 3D trajectory information is available to users to inform ATM decision making.

**1.1.2 Change brought by the module**

This module provides extensions to the baseline, with emphasis on economic descents in airspace with dense traffic levels. Benefits of these Trajectory Based Operations include fuel savings and noise and emission reduction by keeping aircraft at a higher altitude and at lower thrust levels than traditional step-down approaches. Simplifying routes using Optimized Arrivals may also reduce radio transmissions between aircraft crew and controllers.

Benefits of these operations in dense airspace include achieving target traffic and throughput levels while also enabling fuel savings and noise reduction. A traditional assumption is that the use of Optimized Arrivals will reduce throughput in dense airspace, or may not be achievable at all due to complexities created in sequencing Optimized arrivals with non-Optimized arrivals, departures, and crossing traffic.

The aircraft's ability to accurately fly an Optimized Arrival, coupled with the state and intent information sent from the aircraft to [ATC](#) automation, will increase accuracy of trajectory modelling and problem prediction.

**1.1.3 Other**

This module continues the evolution in RNAV and RNP procedure design in dense airspace, and the evolution of automation used to aid in decision support for both air crews and Air Traffic Control.

**1.2 Element 1: Accurate Trajectory Modelling**

This element is focused on obtaining the most accurate trajectory model for use by all automation systems. This includes accurate position information, clearance information, and the use of automated resolutions that reduce controller workload.

**1.3 Element 2: Advanced Aircraft Capabilities**

This element will focus on cockpit capabilities that enable optimal trajectory selection and the ability to fly point-to-point RNAV and RNP procedures. This element will also examine cockpit automation that enables the aircraft to self-separate and avoid potential conflicts. This element will focus on globally-harmonized standards development for trajectory data exchange between the ground and aircraft avionics systems such as the FMS.

**1.4 Element 3: Traffic Flow Management and Time-Based Metering**

This element will harmonize the Traffic Flow Management automation which continuously predicts the demand and capacity of all system resources, and will identify when the congestion risk for any resource (airport or airspace) is predicted to exceed an acceptable risk. Traffic Management will take action in the form of just in time reroutes and metering times to congested resources. The problem resolution element will create a solution that meets all system constraints.

**2. Intended Performance Operational Improvement**

**Metrics to determine the success of the module are proposed in the *Manual on Global Performance of the Air Navigation System (Doc 9883)*.**

<i>Capacity</i>	Better use of terminal airspace. High levels of traffic can be accommodates while still allowing the use of best economy descents that save fuel, emissions, and noise. Capacity will be enhanced by improved ability to plan for flows in and out of the airport.
<i>Efficiency</i>	Time in flight may be reduced to automation that enhances decision making and

	selection of a preferred trajectory.
<i>Environment</i>	Users will fly more fuel and noise efficient arrivals and descent profiles.
<i>Flexibility</i>	Users will be able to select arrival trajectory that best accommodates aircraft according to traffic conditions, weather conditions, and aircraft state.
<i>Safety</i>	Economical descents used without sacrificing safety due to enhanced airspace management and automation to aid in aircraft separation.

<a href="#">CBA</a>	<p>The major qualitative business case elements of this module are as follows:</p> <ul style="list-style-type: none"> <li>• Capacity: Additional flights can be accommodated in terminal airspace because of reduced controller workload and better trajectory modelling/planning.</li> <li>• Efficiency: Users will fly more fuel and noise efficient arrival descent profiles.</li> <li>• Safety: Economic descents flown without sacrificing safety.</li> <li>• Flexibility: Users will have greater flexibility in selecting the flight trajectory that best meets their needs.</li> </ul>
---------------------	--

### 3. Necessary Procedures (Air & Ground)

For strategic actions, the necessary procedures basically exist for Air Navigation Service Providers (ANSPs) and users to collaborate on flight path decisions. Extensions to those procedures will need to be developed to reflect the use of increased decision support automation capabilities, including automation-to-automation negotiation. The use of [ADS-B/CDTI](#) and other cockpit capabilities to support aircraft avoidance is still a research topic and will necessitate procedure development, including the roles of ANSPs. International standards for information exchange between systems to support these operations need to be developed. This includes development of global standards for the exchange of trajectory information between ground and air.

### 4. Necessary System Capability

#### 4.1 Avionics

The continued development of automation for both the cockpit and ANSPs is needed to aid in trajectory modelling and required separation decision making. Aircraft-based capabilities, such as ADS-B/CDTI exist, but applications are still being developed to support the objectives of this module.

#### 4.2 Ground Systems

The continued development of automation for both the cockpit and ANSPs is needed to aid in trajectory modelling and required separation decision making. In addition, development of technology that provides mitigation strategies for conflicts or potential conflicts will also aid in enabling Optimized profiles in dense airspace.

### 5. Human Performance

#### 5.1 Human Factors Considerations

**5.1.1** This module is still in the research and development phase so the human factors considerations are still in the process of being identified through modelling and beta testing. Future iterations of this document will become more specific about the processes and procedures necessary to take the human factors considerations into account. There will be a particular emphasis on identifying the human-machine interface issue if there are any and providing the high risk mitigation strategies to account for them.

#### 5.2 Training and Qualification Requirements

**5.2.1** This module will eventually contain and number of personnel training requirements. As and when they are developed, they will be included in the documentation supporting this module and their importance

signified. Likewise, any qualifications requirements that are recommended will become part of the regulatory needs prior to implementation of this performance improvement.

## 6. Regulatory/standardization needs and Approval Plan (Air & Ground)

- **Regulatory/Standardization:** New or updated requirements and standards are needed that includes:
  - Global standards for trajectory information exchange.
  - ICAO Doc 8168, *Aircraft Operations*;
  - ICAO Doc 4444, *Procedures for Air Navigation Services — Air Traffic Management*, , ATC/Pilot phraseology, such as the use of a “Descend Via” clearance when utilizing an Optimised Arrival
    - **Approval Plans:** To Be Determined.

## 7. Implementation and Demonstration Activities

### 7.1 Current Use

Optimized Arrivals are currently being used at the following U.S. airports in dense airspaces:

- Los Angeles International Airport (LAX)
- Phoenix Sky Harbor International Airport (PHX)
- Atlanta Hartsfield International Airport (ATL)
- Las Vegas International Airport (LAS)

### 7.2 Planned or Ongoing Trials

**US / Europe** – Current work is being completed to validate trajectory performance required to support advanced TBO.

#### United States:

- Completing simulation and modelling to validate trajectory modelling accuracy
- FIXM / Data link work that is being completed with SESAR to standardize trajectory data elements.
- Airborne Reroute currently in development which will provide just in time congestion resolution to the aircraft during congested events.

## 8. Reference Documents

### 8.1 Standards

### 8.2 Procedures

### 8.3 Guidance Material

- ICAO Doc 9931, *Continuous Descent Operations (CDO) Manual*.

### 8.4 Approval Documents

- Global standards for trajectory information exchange. (Update required)
- ICAO Doc 8168, *Aircraft Operations*; (Updated required)
- ICAO Doc 4444, *Procedures for Air Navigation Services — Air Traffic Management*, , [ATC](#)/Pilot phraseology, such as the use of a “Descend Via” clearance when utilizing an Optimised Arrival (Update required).

**This Page Intentionally Left Blank**

## Module N° B3-05: Full 4D Trajectory-based Operations

<b>Summary</b>	The development of advanced concepts and technologies, supporting four dimensional trajectories, to enhance global ATM decision making. A key emphasis is on integrating all flight information to obtain the most accurate trajectory model for ground automation.	
<b>Main Performance Impact</b>	KPA-02 Capacity; KPA-04 Efficiency; KPA-05 Environment; KPA-10 Safety;	
<b>Operating Environment / Flight Phases</b>	En-route/Cruise, Terminal Area, Traffic Flow Management, Descent	
<b>Applicability Considerations</b>	Applicable to air traffic flow planning, en-route operations, terminal operations (arrival/departure), and arrival operations. Benefits accrue to both flows and individual aircraft. Aircraft equipage is assumed in the areas of: <a href="#">ADS-B In/CDTI</a> ; data communication and advanced navigation capabilities. Requires good synchronization of airborne and ground deployment to generate significant benefits, in particular to those equipped. Benefit increases with size of equipped aircraft population in the area where the services are provided.	
<b>Global Concept Component(s)</b>	AOM - Airspace Organization and Management DCB - Demand and Capacity Balancing AUO - Airspace User Operations TS - Traffic synchronization CM - Conflict management	
<b>Global Plan Initiatives (GPI)</b>	GPI-5- RNAV/RNP (Perf. Based Nav) GPI-11- RNP and RNAV SIDs and STARs GPI-16- Decision Support Systems and Alerting Systems	
<b>Main Dependencies</b>	B1-40, B2-31, B2-05,	
<b>Global Readiness Checklist</b>		<b>Status</b> (indicate ready with a tick or input date)
	Standards Readiness	2025
	Avionics Availability	2028
	Ground Systems Availability	2028
	Procedures Available	2028
	Operations Approvals	2028

### 1. Narrative

#### 1.1 General

This module implements 4D trajectory based operations that use the capabilities of aircraft Flight Management Systems to optimize aircraft flight trajectories in four dimensions. Full TBO integrates advanced capabilities that will provide vastly improved surveillance, navigation, data communications, and automation for ground and airborne systems with changes in service provider roles and responsibilities.

##### 1.1.1 Baseline

This module deploys an accurate four-dimensional trajectory that is shared among all of the aviation system users at the cores of the system. This provides consistent and up-to-date information system wide which is integrated into decision support tools facilitating global ATM decision-making. It continues the evolution in procedures and automation capabilities, both ground-based and aircraft-based, for using accurate trajectories to benefits the system. Optimized arrivals in dense airspace were previously enabled. Decision support capabilities are available that are integrated to assist ANSPs and users to make better decisions in arrival profile optimization. A consistent, integrated information base is available to all ANSPs and users to inform ATM decision making.

With 4D trajectory operations, Block 3 will see the achievement of capabilities which optimize the individual trajectories, the traffic flows and the use of scarce resources such as runways and surface. This module is focused on the core 4D capabilities, while modules B3-15 and B3-10 focus on the optimization of specific situations (high density/complexity).

### 1.1.2 Change brought by the module

In future en route airspace, mixed levels of aircraft performance and air crew authorizations are expected. High-performance aircraft will be capable of flying RNAV routes, accurately conforming to their route of flight, supporting data communications, communicating requests and aircraft state and intent information digitally with the ATC automation, and receiving clearances and other messages digitally from the ATC automation.

Some en route airspace will be designated for high-performance aircraft only, allowing the air traffic control (ATC) system to engage operations that fully leverage the capabilities of those aircraft. Aircraft will communicate state and intent information to the ATC automation and closely follow their intended routes of flight. As a result, the automated problem prediction and resolution capabilities will be able to maximize user benefits by supporting user-preferred flight plans, minimizing changes to those plans as aircraft traverse the NAS, and improving services provided.

The controller's primary responsibilities will be to respond to problems predicted by the ATC automation, and to maintain accurate flight information in the ATC automation. Predicted problems will include:

- Aircraft to aircraft conflicts
- Aircraft to special use or other types of restricted airspaces
- Aircraft to severe weather forecast areas
- Aircraft to metering constraint problems including miles in trail restrictions
- The aircraft's capability to accurately fly its cleared route of flight, coupled with the state and intent information sent from the aircraft to the ATC automation, will increase the accuracy of trajectory modelling and problem prediction. Key aspects of Full TBO are:
- The basis for all operations is an accurate four-dimensional trajectory that is shared among all of the aviation system users.
- Consistent and up-to-date information describing flights and air traffic flows are available system-wide, supporting both user and service provider operations.
- Data Communication is used between the ground and aircraft to improve the accuracy of trajectories, request changes in 4D trajectory, provide precise clearances to the flight, and exchange information without controller involvement.
- Area Navigation (RNAV) operations remove the requirement for routes to be defined by the location of navigational aids, enabling the flexibility of point-to-point aircraft operations.
- Required Navigation Performance (RNP) operations introduce the requirement for onboard performance monitoring and alerting. A critical characteristic of RNP operations is the ability of the aircraft navigation system to monitor its achieved navigation performance for a specific operation, and inform the air crew if the operational requirement is being met.
- En route controllers rely on automation to identify conflicts and propose resolutions allowing them to focus on providing improved services to the users.
- The ability of cockpit automation to fly the aircraft more precisely and predictably reduces routine tasks of controllers.
- Performance-based services that require minimum flight performance levels are provided in designated airspace.
- Flow management automation will propose incremental congestion resolutions that will maintain congestion risk at an acceptable level, using flight-specific alternative intent options to the extent possible. Flight operation centres (FOC) will dynamically re-calculate and furnish the flight crew and flow management updated intent options and priority of the options as conditions change.
- Time-based flow management that coordinates arrival flows for high traffic airports.

**1.2 Element 1: Advanced Aircraft Capabilities**

This element focuses on aircraft-based capabilities that assist pilots with weather and other aircraft avoidance, and thus enhance safety. Examples of such capabilities are [ADS-B In](#), air-to-air information exchange, and integration of weather into cockpit-based automation tools. This element also focuses on globally-harmonized standards development for trajectory data exchange between the ground and aircraft avionics systems such as the [FMS](#).

**1.3 Element 2: Problem Detection and Resolution**

This element will continue the evolution to the use of ATM decision support tools, by ANSPs and users, which provide manoeuvres for flying the most economical descent profiles. Based on experiences gained from development and deployment of initial capabilities, extensions will be developed to generate more efficient and operationally acceptable arrival profile solutions. This element will also explore direct automation-to-automation negotiation capabilities to streamline the development of mutually acceptable ATM solutions. This element is will also focus on getting the most accurate trajectory model in the system for use by all automation functions. This entails putting every clearance given to the aircraft into the automation, using automation generated resolutions to make it easier for the controllers to enter the clearance, and receiving flight specific data from the aircraft to include in the trajectory calculation and any resolution options.

**1.4 Element 3: Traffic Flow Management and Time-Based Metering**

This element will harmonize the Traffic Flow Management automation which continuously predicts the demand and capacity of all system resources, and will identify when the congestion risk for any resource (airport or airspace) is predicted to exceed an acceptable risk. Information from FOCs or flight crews indicates intent options and preferences, so that user reactions and adjustments to the 4DT to address constraints such as weather are accounted before the [ANSP](#) would take action. Traffic Management will take action in the form of just in time reroutes and metering times to congested resources. The problem resolution element will create a manoeuvre that meets all system constraints.

**2. Intended Performance Operational Improvement**

**Metrics to determine the success of the module are proposed in the *Manual on Global Performance of the Air Navigation System (Doc 9883)*.**

<i>Capacity</i>	a. Additional flights can be accommodated because of reduced controller workload. Less conservative decisions about permitting aircraft to utilize the airspace results in more aircraft being able to traverse the affected area. Similarly, terminal arrival/departure capacity will be enhanced by improved ability to plan for flows in and out of the airport.
<i>Efficiency</i>	Harmonized avionics standards Cost savings and environmental benefits through reduced fuel burn Users will be better able to plan and receive their preferred trajectory
<i>Environment</i>	Users will be better able to plan and receive their preferred trajectory Cost savings and environmental benefits through reduced fuel burn
<i>Safety</i>	a. Increased flight crew situational awareness b. Reduction of conflicts between aircraft and more lead time in resolving those conflicts that exist. c. Number of incident occurrences

<a href="#">CBA</a>	The business case is still to be determined as part of the development of this module, which is in the research phase. Current experience with utilization of enhanced weather information to improve ATM decision making by stakeholders has proven to be positive due to the benefits of more efficient flight planning and less disruption to user-preferred trajectories.
---------------------	---



### 3. Necessary Procedures (Air & Ground)

The use of ADS-B/CDTI and other cockpit capabilities to support aircraft avoidance is still a research topic and will necessitate procedures development, including the roles of ANSPs.

For strategic actions, the necessary procedures basically exist for ANSPs and users to collaborate on flight path decisions. Extensions to those procedures will need to be developed to reflect the use of increased decision support automation capabilities, including automation-to-automation negotiation.

For strategic actions, the necessary procedures basically exist for ANSPs and users to collaborate on flight path decisions. Extensions to those procedures will need to be developed to reflect the use of increased decision support automation capabilities, including automation-to-automation negotiation.

### 4. Necessary System Capability (Air & Ground)

#### 4.1 Avionics

For this longer-term element, the needed technology is still in development. Aircraft-based capabilities, such as RTA exist, but applications are still being developed to support their extension (e.g. multiple RTA, ...) .

#### 4.2 Ground Systems

For the longer-term element, the needed technology is still in development. For ground-based technology, research is on-going into decision support tools that produce fuel efficient resolutions, and support the automated development of candidate mitigation strategies. Work is also needed to incorporate data from aircraft systems into ground trajectory models to ensure the most accurate trajectory.

### 5. Human Performance

#### 5.1 Human Factors Considerations

**5.1.1** This module is still in the research and development phase so the human factors considerations are still in the process of being identified through modelling and beta testing. Future iterations of this document will become more specific about the processes and procedures necessary to take the human factors considerations into account. There will be a particular emphasis on identifying the human-machine interface issue if there are any and providing the high risk mitigation strategies to account for them.

#### 5.2 Training and Qualification Requirements

**5.2.1** This module will eventually contain and number of personnel training requirements. As and when they are developed, they will be included in the documentation supporting this module and their importance signified. Likewise, any qualifications requirements that are recommended will become part of the regulatory needs prior to implementation of this performance improvement.

### 6. Regulatory/Standardization needs and Approval Plan (Air & Ground)

- **Regulatory/Standardization:** Updates as required for enhanced information exchange ground-ground and air-to-air in:
  - ICAO Doc 4444, *Procedures for Air Navigation Services — Air Traffic Management*, .
  - ICAO Doc XXXX, PANS-AIM
  - FAA AC TBD, EASA AMD TBD
- **Approval Plans:** TBD.

#### 6.1 Element 1: Advance Aircraft Capabilities

International standards for information exchange between systems to support these operations need to be developed. This includes development of global standards for the exchange of trajectory information between ground and air.

International standards for information exchange between systems to support these operations need to be developed. This includes development of global standards for the exchange of trajectory information between ground and air. Included in this is development of global standards for trajectory information

exchange and certification decision on aircraft-based aircraft display and dissemination. Dissemination includes air-to-ground as well as air-to-air exchange of those observations via ADS-B

## 7. Implementation and Demonstration Activities

### 7.1 Current Use

Since this module is in the category of Long Term Issues, there are no examples of current operational use. Numerous entities are conducting research on ADS-B In applications that relate to aircraft avoidance via cockpit functionality. Such research efforts will help to inform the work to be done under this block.

### 7.2 Planned or Ongoing Trials

#### 7.2.1 Element 1: Advance Aircraft Capabilities

No global demonstration trials are currently planned for this module. There is a need to develop such a plan as part of the collaboration on this module.

## 8. Reference Documents

- ICAO Annex 10 — *Aeronautical Telecommunications*, Volume II — Communication Procedures including those with PANS Status; ICAO Doc 4444, *Procedures for Air Navigation Services — Air Traffic Management*;
- ICAO Doc 9694, *Manual of Air Traffic Services Data Link Applications* ;
- NextGen and SESAR Operational Concepts;
- EUROCAE ED-100A / RTCA DO-258A, Interoperability Requirements for ATS Applications using ARINC 622 Data Communications;
- EUROCAE ED-110 / RTCA DO-280, Interoperability Requirements Standard for Aeronautical Telecommunication Network Baseline 1 (Interop ATN B1) ;
- EUROCAE ED-120 / RTCA DO-290, Safety and Performance Requirements Standard For Initial Air Traffic Data Link Services In Continental Airspace (SPR IC);
- EUROCAE ED-122 / RTCA DO-306, Safety and Performance Standard for Air Traffic Data Link Services in Oceanic and Remote Airspace (Oceanic SPR Standard);
- EUROCAE ED-154 / RTCA DO-305, Future Air Navigation System 1/A – Aeronautical Telecommunication Network Interoperability Standard ([FANS](#) 1/A – ATN B1 Interop Standard);
- EUROCAE WG78/RTCA SC214 Safety and Performance requirements and Interoperability requirements.

### 8.1 Approval Documents

- ICAO Doc 4444, *Procedures for Air Navigation Services — Air Traffic Management*, (update required);
- ICAO Doc XXXX, PANS-AIM (expected publication 2016);
- FAA AC TBD, EASA AMD TBD.

## **Performance Improvement Area 4: Efficient Flight Path – Through Trajectory-based Operations.**

***Thread: Trajectory-Based Operations***

This Page Intentionally Left Blank

## Module N° B0-40: Improved Safety and Efficiency through the initial application of Data Link En-Route

<b>Summary</b>	To implement an initial set of data link applications for surveillance and communications in <a href="#">ATC</a> , supporting flexible routing, reduced separation and improved safety.	
<b>Main Performance Impact</b>	KPA-02 Capacity; KPA-10 Safety	
<b>Operating Environment/Phases of Flight</b>	En-route flight phases, including areas where radar systems cannot be installed such as remote or oceanic airspace.	
<b>Applicability Considerations</b>	Requires good synchronization of airborne and ground deployment to generate significant benefits, in particular to those equipped. Benefits increase with the proportion of equipped aircraft.	
<b>Global Concept Component(s)</b>	IM – Information Management SDM – Service Delivery Management	
<b>Global Plan Initiatives (GPI)</b>	GPI-9 Situational awareness GPI-17 Implementation of data link applications GPI-18 Electronic information services	
<b>Main Dependencies</b>		
<b>Global Readiness Checklist</b>		<b>Status</b> (ready now or estimated date)
	Standards Readiness	✓
	Avionics Availability	✓
	Ground Systems Availability	✓
	Procedures Available	✓
	Operations Approvals	✓

### 1. Narrative

#### 1.1 General

Air-ground data exchanges have been the subject of decades of research and standardization work and are an essential ingredient of the future operational concepts since they can carry reliably richer information than what can be exchanged over radio. Many technologies exist and have been implemented now widely in aircraft, often motivated by AOC and AAC reasons as well. Since a few years a number of applications have started to become a reality for ATM, but they are not completely deployed. In addition, there are ongoing further efforts to ensure that the applications are interoperable to diverse a/c fits, a task being addressed with priority by the OPLINK panel. This module covers what is available and can be more widely used now.

One element of the module is the transmission of aircraft position information, forming the Automatic Dependent Surveillance (ADS-C) service, principally for use over oceanic and remote areas where radar cannot be deployed for physical or economical reasons.

- 3.1.1 A second element is Controller Pilot Data Link Communications (CPDLC) comprising a first set of data link applications allowing pilots and controllers to exchange ATC messages concerning Communications management, ATC Clearances and stuck microphones. CPDLC reduces misunderstandings and controller workload giving increased safety and efficiency whilst providing extra capacity in the ATM system.

### 1.1.1 Baseline

Prior to this module, air-ground communications use voice radio (VHF or HF depending on the airspace), known for its limitations in terms of quality, bandwidth and security. There are also wide portions of the globe with no radar surveillance. ATC instructions, position reports and various information have to be transmitted through HF radios where voice quality is really bad most of the times, leading to significant workload to controllers and pilots (including HF radio operators), poor knowledge of the traffic situation outside radar coverage, large separation minima, and misunderstandings. In high density airspace controllers currently spend 50% of their time talking to pilots on the VHF voice channels where frequencies are a scarce resource; this also represents a significant workload for controllers and pilots and generates misunderstandings.

### 1.1.2 Change brought by the module

The module concerns the implementation of a first package of data link applications, covering [ADS-C](#), CPDLC and other applications for [ATC](#). These applications provide significant improvement in the way ATS is provided as described in the next section.

An important goal of the global ATM concept within the area of data link is to harmonise the regional implementations and to come to a common technical and operational definition, applicable to all flight regions in the world. This is planned to be achieved through Block 1 changes. Data link implementations today are based on different standards, technology and operational procedures although there are many similarities.

#### 1.2 Element 1: [ADS-C](#) over Oceanic and Remote Areas

ADS-C provides an automatic dependent surveillance service over oceanic and remote areas, through the exploitation of position messages sent automatically by aircraft over data link at specified time intervals (ADS-Contract). This improved situational awareness (in combination with appropriate [PBN](#) levels) is improving safety in general and allows reducing separations between aircraft and progressively moving away from pure procedural modes of control.

#### 1.3 Element 2: Continental [CPDLC](#)

The applications allow pilots and controllers to exchange messages with a better quality of transmission. In particular, they provide a way to alert the pilot when its microphone is stuck and a complementary means of communication.

Over dense continental airspace, they can significantly reduce the communication load, allowing the controller to better organise its tasks, in particular by not having to interrupt immediately to answer radio. They provide more reliability on the transmission and understanding of frequency changes, flight levels and flight information etc., thereby increasing safety and reducing the number of misunderstandings and repetitions.

## 2. Intended Performance Operational Improvement

### 2.1 Element 1: [ADS-C](#) over Oceanic and Remote Areas

Metrics to determine the success of the module are proposed in the *Manual on Global Performance of the Air Navigation System (Doc 9883)*.

<i>Capacity</i>	A better localisation of traffic and reduced separations allow increasing the offered capacity.
<i>Efficiency</i>	Routes/tracks and flights can be separated by reduced minima, allowing to apply flexible routings and vertical profiles closer to the user-preferred ones.
<i>Flexibility</i>	<a href="#">ADS-C</a> permits to make route changes easier

<i>Safety</i>	Increased situational awareness; ADS-C based safety nets like CLAM, RAM, DAIW; better support to SAR
---------------	--

<u>CBA</u>	<p>The business case has proven to be positive due to the benefits that flights can obtain in terms of better flight efficiency (better routes and vertical profiles; better and tactical resolution of conflicts).</p> <p>To be noted, the need to synchronise ground and airborne deployments to ensure that services are provided by the ground when aircraft are equipped, and that a minimum proportion of flights in the airspace under consideration are suitably equipped.</p>
------------	--

## 2.2 Element 2: Continental CPDLC

Metrics to determine the success of the module are proposed at Doc 9883.

<i>Capacity</i>	Reduced communication workload and better organisation of controller tasks allow to increase sector capacity
<i>Safety</i>	Increased situational awareness; reduced occurrences of misunderstandings; solution to stuck mike situations

<u>CBA</u>	<p>The European business case has proven to be positive due to</p> <ul style="list-style-type: none"> <li>• the benefits that flights can obtain in terms of better flight efficiency (better routes and vertical profiles; better and tactical resolution of conflicts).</li> <li>• reduced controller workload and increased capacity.</li> </ul> <p>A detailed business case has been produced in support of the EU Regulation which was solidly positive.</p> <p>To be noted, there is a need to synchronise ground and airborne deployments to ensure that services are provided by the ground when aircraft are equipped, and that a minimum proportion of flights in the airspace under consideration are suitably equipped.</p>
------------	---

## 3. Necessary Procedures (Air & Ground)

Procedures have been described and are available in ICAO documents: Manual of Air Traffic Services Data Link Applications (Doc 9694), GOLD Global Operational Data Link Document

## 4. Necessary System Capability

### 4.1 Avionics

Standards for the enabling technology are available in ICAO documents and industry standards.

Today, the existing Data Link implementations are based on two sets of ATS Data link services: FANS 1/A and ATN B1, both will exist. FANS1/A is deployed in Oceanic and Remote regions whilst ATN B1 is being implemented in Europe according to European Commission legislation (EC Reg. No. 29/2009) – the Datalink Services Implementing Rule.

These two packages are different from the operational, safety and performance standpoint and do not share the same technology but there are many similarities and can be accommodated together, thanks to the resolution of the operational and technical issues through workaround solutions, such as accommodation of FANS 1/A aircraft implementations by ATN B1 ground systems and dual stack (FANS 1/A and ATN B1) implementations in the aircraft.

## 4.2 Ground Systems

For ground systems, the necessary technology includes the ability to manage [ADS-C](#) contract, process and display the ADS-C position messages. CPDLC messages need to be processed and displayed to the relevant ATC unit. Enhanced surveillance through multi-sensor data fusion facilitates transition to/from radar environment.

## 5. Human Performance

### 5.1 Human Factors Considerations

**5.1.1** ADS-C is a means to provide the air traffic controller with a direct representation of the traffic situation, and reduces the task of controllers or radio operators to collate position reports. In addition to providing another channel of communications, the data link applications allow in particular air traffic controllers to better organise their tactical tasks. Both pilots and controllers benefit from a reduced risk of misunderstanding of voice transmissions.

**5.1.2** Data communications allow reducing the congestion of the voice channel with overall understanding benefits and more flexible management of air-ground exchanges. This implies an evolution in the dialog between pilots and controllers which must be trained to use data link rather than radio. Automation support is needed for both the pilot and the controller. Overall their respective responsibilities will not be affected.

**5.1.3** Human Factors have been taken into consideration during the development of the processes and procedures associated with this module. Where automation is to be used, the Human-Machine interface has been considered from both a functional and ergonomic perspective (See Section 6 for examples). The possibility of latent failures however, continues to exist and vigilance is requested during all implementation actions. It is further requested that human factor issues, identified during implementation, be reported to the international community through ICAO as part of any safety reporting initiative.

### 5.2 Training and Qualification Requirements

**5.2.1** Automation support is needed for both the pilot and the controller which therefore will have to be trained to the new environment and to identify the aircraft/facilities which can accommodate the data link services in mixed mode environments.

**5.2.2** Training in the operational standards and procedures are required for this module and can be found in the links to the documents in Section 8 to this module. Likewise, the qualifications requirements are identified in the regulatory requirements in Section 6 which form an integral part to the implementation of this module.

## 6. Regulatory/standardisation needs and Approval Plan (Air & Ground)

- **Regulatory/Standardization:** Use current published requirements that includes the material given in Section 8.4. It should also be noted that new ICAO OPLINK Ops Guidance is under development
- **Approval Plans:** Must be in accordance with application requirements

## 7. Implementation and Demonstration Activities

### 7.1 Current Use

#### 7.1.1 [ADS-C](#)

- **Remote & Oceanic areas:** ADS-C is used primarily over remote and oceanic areas. Dependent surveillance (ADS-C) is already successfully used in a number of regions of the world, for example in the [CAR/SAM](#) region ([COSESNA](#), Brazil, etc) or in the South Pacific for FANS 1/A aircraft in combination with CPDLC messages. Also, in the NOPAC (NORTH PACific) route system it has allowed a reduction of separation minima.
- **Australia:** Australia has been operationally using CPDLC since the late 1990's and has provided ADS-C / CPDLC capability to all en-route controller positions since 1999. Integrated ADS-C and [CPDLC](#) based on FANS1A are used both in domestic en-route and oceanic airspace



- **Atlantic:** In March 2011, NAV CANADA and NATS implemented Reduced Longitudinal Separation Minima (RLongSM) of five minutes for properly equipped aircraft on tracks across the Atlantic. RLongSM requires aircraft to be equipped with GNSS, ADS-C and CPDLC. Along with other procedural improvements, this will allow more aircraft to access optimal altitudes. The expected result is an estimated \$1 million in customer fuel savings in the first year, along with 3,000 metric tons of emissions savings.
- **India:** [ADS-C](#) and [CPDLC](#) based on [FANS](#) 1/A has been in operation in Bay of Bengal and Arabian Sea Oceanic areas since 2005. India along with other South Asian countries has introduced 50 nm RLS (Reduced Longitudinal Separation) in 2 RNAV ATS routes from July 2011 for aircraft with data link capability. The RLS will be introduced in 8 RNAV routes from December 2011. BOBASMA (Bay of Bengal Arabian Sea Safety monitoring Agency) has been established in Chennai, India to support RLS operations and is endorsed by RASMAG/15.
- **Europe:** [CPDLC](#) data link services are being implemented, namely Data Link Communications Initiation Capability (DLIC), ATC Communications Management service (ACM), ATC Clearances and Information service (ACL) and ATC Microphone Check service (AMC). To support them, the [ATN](#) B1 package is currently being deployed in 32 European Flight Information Regions and Upper Flight Information Regions above FL285 (known as the LINK2000+ service deployment). European Commission legislation (EC Reg. No. 29/2009) – the Datalink Services Implementing Rule - mandates implementation of a compliant solution:
  - From Feb 2013, in core European ground systems and
  - From Feb2015, in the whole of Europe.
  - From Jan 2011, on newly produced aircraft intending to fly in Europe above FL285
  - From Feb 2015, retrofitted on all aircraft flying in Europe above FL285,

Note: Aircraft fitted with FANS1/A prior to 2014 for Oceanic operations are exempt from the regulation. In an effort to promote technical compatibility with the existing FANS 1/A+ fleet, a Mixed Interoperability document (ED154/DO305) was created that allows ATN B1 ground systems to provide ATS Datalink service to FANS 1/A+ aircraft. So far 7 out of 32 Flight Information Regions and Upper Flight Information Regions have indicated they will accommodate FANS 1/A+ aircraft.

Note: data link is operational at the Maastricht UAC since 2003. The [PETAL](#) II project extension finalised the validation of the ATN B1 applications by executing a pre-operational phase where aircraft equipped with certified avionics conducted daily operations with controllers in Maastricht Upper Airspace. The results were documented in the PETAL II Final Report and lead to the creation of the LINK 2000+ Programme to co-ordinate full scale European Implementation.

Note: The decision of implementation is accompanied by an economic appraisal, business case and other guidance material available at the following address: [http://www.EUROCONTROL.int/link2000/public/site\\_preferences/display\\_library\\_list\\_public.html#6](http://www.EUROCONTROL.int/link2000/public/site_preferences/display_library_list_public.html#6) .

- **US:** Domestic Airspace: Beginning in 2014 Departure Clearance Services will be deployed using FANS-1/A+. In 2017, En-route Services will begin deployment to domestic en-route airspace.

## 7.2 Planned or Ongoing Trials

### 7.2.1 [ADS-C](#)

- **United States - ADS-C In Trail Climb Procedure trial currently being conducted Expected operational use in 2016.**

### 7.2.2 [CPDLC](#)

- **United States – Datacomm Departure Clearance Service (DCL) Trial will commence by 2014.**

## 8. Reference Documents

### 8.1 Standards

- Commission Regulation (EC) No 29/2009 of 16 January 2009 laying down requirements on data link services for the single European sky
- EUROCAE ED-100A / RTCA DO-258A, Interoperability Requirements for ATS Applications using ARINC 622 Data Communications

- EUROCAE ED-110 / RTCA DO-280, Interoperability Requirements Standard for Aeronautical Telecommunication Network Baseline 1 (Interop ATN B1)
- EUROCAE ED-120 / RTCA DO-290, Safety and Performance Requirements Standard For Initial Air Traffic Data Link Services In Continental Airspace (SPR IC)
- EUROCAE ED-122 / RTCA DO-306, Safety and Performance Standard for Air Traffic Data Link Services in Oceanic and Remote Airspace (Oceanic SPR Standard)
- EUROCAE ED-154 / RTCA DO-305, Future Air Navigation System 1/A – Aeronautical Telecommunication Network Interoperability Standard (FANS 1/A – ATN B1 Interop Standard)

#### **8.4 Procedures**

Nil

#### **8.5 Guidance Material**

- ICAO Doc 9694, *Manual of Air Traffic Services Data Link Applications*;
- New OPLINK Ops Guidance (under development).

#### **8.4 Approval Documents**

- ICAO Doc 9694, *Manual of Air Traffic Services Data Link Applications*;
- FAA AC20-140A, Guidelines for Design Approval of Aircraft Data Link Communication Systems Supporting Air Traffic Services (ATS);
- RTCA/EUROCAE DO-306/ED-122;
- RTCA/EUROCAE DO-305/ED-154;
- RTCA/EUROCAE DO-290/ED-120;
- RTCA/EUROCAE DO-280/ED-110B;
- RTCA/EUROCAE DO-258A/ED-100A;
- EC Regulation No. 29/2009: Datalink Services Implementing Rule;
- New OPLINK Material under development.

## Module N° B1-40: Improved Traffic Synchronization and Initial Trajectory-Based Operation

<b>Summary</b>	To improve the synchronization of traffic flows at en-route merging points and to optimize the approach sequence through the use of 4DTRAD capability and airport applications, e.g.; <a href="#">D-TAXI</a> .	
<b>Main Performance Impact</b>	KPA-02 Capacity; KPA-04 Efficiency; KPA-05 Environment; KPA-09 Predictability KPA-10 Safety	
<b>Operating Environment/Phases of Flight</b>	All flight phases	
<b>Applicability Considerations</b>	Requires good synchronization of airborne and ground deployment to generate significant benefits, in particular to those equipped. Benefit increases with size of equipped aircraft population in the area where the services are provided.  Not applicable to light aircraft.	
<b>Global Concept Component(s)</b>	IM – Information Management TS – Traffic Synchronization CM – Conflict Management	
<b>Global Plan Initiatives (GPI)</b>	GPI-9 Situational awareness GPI-17 Implementation of data link applications GPI-18 Aeronautical Information (Japan and Jordan)	
<b>Pre-Requisites</b>	B0-40. Linkage with B1-25	
<b>Global Readiness Checklist</b>		<b>Status</b> (ready now or estimated date)
	Standards Readiness	<b>2013</b>
	Avionics Availability	<b>Est. 2016</b>
	Ground Systems Availability	<b>Est. 2016</b>
	Procedures Available	<b>Est. 2018</b>
	Operations Approvals	<b>Est. 2018</b>

### 1. Narrative

#### 1.1 General

This module is a step towards the goal to introduce 4D trajectory based operations that uses the capabilities of aircraft Flight Management Systems to optimize aircraft flight trajectories in four dimensions. Trajectory Based Operations will manage uncertainty by improving predictability for all ATM Stakeholders across all boundaries or ATM sector structures. In this context it will facilitate Traffic Synchronization and strategic Conflict Management supported by Separation Provision that minimises tactical “radar type” intervention (e.g. open loop vectoring). It also introduces a number of Airport applications that increase safety and reduce controller-pilot workload.

#### 1.1.1 Baseline

Traffic synchronization is based on the flight data processing information fed by flight plan data with current positions updated by radar information and on mental extrapolation by controllers. This is not accurate and

represents a workload for assessing the situation and monitoring its evolution. Actions are difficult to anticipate in upstream sectors which may not be aware of the problem to be solved.

The transmission of information at and around airports, including for complex routings is done through voice radio, implying a high workload for pilots and controllers, frequent misunderstandings and repetitions.

### 1.1.2 Change brought by the module

This module implements additional air-ground data link applications to: download trajectory information and improve the synchronization of traffic flows at merging points, in particular in view of optimising an approach sequence, with negotiation of a required time of arrival using the FMS functionality. Existing ground-ground coordination capabilities will be improved to allow complex route clearances to be exchanged across multiple airspace boundaries.

The module will also implement data transmission for airport/TMA related information and clearances.

### 1.2 Element 1: Initial 4D Operations (4DTRAD)

Supporting this is 4DTRAD, a recognized approach to initial Trajectory Based Operations which offers an advanced view of the future ATM environment including seamless integration of operational goals through an increased situational awareness and by the sharing of air ground data in a strategic and tactical collaborative decision making environment.

4DTRAD requires the availability of sophisticated air ground data exchange that includes use of new [ADS-C](#) and data link functionality beyond current capabilities and performance requirements. Furthermore, ground-ground data exchange to exchange complex clearances needs to be secure, widely available.

As a step transition to Trajectory Based Operations, the introduction of a common time reference with the use of aircraft [FMS](#) required time of arrival (RTA) and speed control with less demanding performance and technology requirements to that of 4DTRAD promises early predictability and efficiency benefits to airspace users and service providers.

Using the aircraft RTA for planning arrival flows from En-route (or Oceanic) into Terminal airspace is feasible using current aircraft capability with lower performance requirements than for example 4DTRAD. This would only focus on building traffic flows and sequences leaving more precise metering and separation provision to be achieved through current operations or with new RNAV performance-based navigation procedures.

Synchronising the RTA and Controlled Time of Arrival (CTA) with appropriate PBN levels offers the opportunity to further develop stable and predictable traffic flows into a Terminal area, letting the pilot optimize the flight profile (e.g. top of descent and descent profile).

Furthermore, predictable pre-planned traffic flows facilitate consistent application of Continuous Descent Operations and Tailored Arrival procedures whilst Terminal holding can be avoided through pre-planned path stretching undertaken by the aircraft using the RTA or speed control as well as integrating both long and short haul flights into arrival sequences.

The deployment of RNP/RNAV procedures and use of techniques such as “Point Merge” and others provide the opportunity to manage aircraft without recourse to radar vectoring intervention, leading to a closed loop FMS operation and an informed ground system supporting efficient aircraft profiles and predictable ATM operations.

To realise such benefits, communication between en-route and terminal control units is needed to coordinate the CTA constraint which may be achieved through existing mechanisms such as on-line data exchange with delivery to the aircraft via R/T or coordination with the airline operations centres to deliver to long haul aircraft by company data link.

A wider approach to the block will consider the combination with arrival management techniques using currently available ground based tools providing a more demanding performance facilitating refined metering of traffic into Terminal airspace and existing CPDLC capability to deliver the CTA.

A first step which relies on existing systems and capabilities or requiring only minor modifications will make use of current [FMS](#) capability to define and output an RTA or speed control. Existing data link capabilities such as CPDLC, AOC, or even voice could be used to agree this RTA or speed control with the ground CTA. Most ground systems are incorporating trajectory prediction functionality and existing AMAN calculate the equivalent of a CTA. Ground-ground communications infrastructure will enable the exchange of flight plan and can be updated to exchange [CTA](#).

Beyond this first step more significant changes are anticipated to enable 4DTRAD and trajectory based operations with advanced, and standardized FMS functionality able to provide more accurate and complete trajectory information which could be down linked with new ADS-C or [CPDLC](#) protocols. Depending on the definition of this trajectory information for download new data link technology may be required in the long term. The ground-ground communication infrastructure, in the context of SWIM will enable this trajectory information to be made available to the various en-route, terminal and airport systems which can use the common trajectory reference. System modifications to make full use of this trajectory information must also be planned.

Initial 4D operations can be broken down in to two steps; the first is the synchronization between air and ground of the flight plan or Reference Business Trajectory. The second step is imposing a time constraint and allowing the aircraft to fly its profile in the most optimal way to meet that constraint.

### ***Trajectory Synchronization and Monitoring***

The ATM system relies on all actors having the same view; it is therefore essential that the trajectory in the Flight Management System (FMS) is synchronized with that held on the ground in the Flight Data Processing Systems (FDPS) and the wider Network systems.

The crew and the ATC agree on the trajectory to be flown and during the entire execution, they continuously check if it is, and will be, followed by the aircraft. In case of non-conformance warnings are raised and a new interaction between the crew and the responsible ATC occurs.

The early air/ground agreement on the trajectory to be flown and its execution allows the FMS to optimize the trajectory providing efficiency benefits to the User in terms of aircraft flight profile optimization and ensuring maximum environmental benefits, both through reduced fuel burn and optimum routings en-route, in the Terminal Area and in the vicinity of the airport avoiding noise sensitive areas.

Improved consistency between air & ground trajectory ensures that controllers have highly reliable information on aircraft behaviour. This more accurate trajectory prediction enables better performance from the decision support tools providing a better anticipation of congestion by allowing early detection of traffic bunching providing better adaptation to the real traffic situation and reduced inefficient radar based tactical intervention.

The increased levels of predictability mean that potential conflicts within a medium-term time horizon will be identified and resolved early while the increased accuracy of ground computed trajectory, especially for short term prediction, reduces the risk of unexpected events.

### ***Required Time of Arrival***

The avionics function, Required Time of Arrival (RTA), can be exploited by both en-route and TMA controllers for demand/capacity balancing, metering of flows and sequencing for arrival management.

By preparing the metering of aircraft at an earlier stage of their flight the impact of the constraint is minimised. This allows ATC to make optimum use of capacity at the right time, minimising risks through complexity reduction to ensure that human capabilities are not exceeded. This also supports optimized aircraft profile management by the pilot.

Reduction of inefficient ATC tactical interventions through early planning of traffic en-route and in to the arrival management phase avoids severe and costly sequencing measures. This process enhances aircraft profile optimization, flight predictability and allows improvements in the stability and reliability of the sequence built by ATC.

It should lead to reduced need for aircraft to hold, inefficiently burning fuel with the associated chemical and noise pollution. Aircraft will be able to plan better and adhere more accurately to arrival schedules leading to better planning for the airlines due to increased flight predictability.

## ***1.3 Element 2: Data Link Operational Terminal Information Service (D-OTIS)***

Before flight departure, the flight crew may request meteorological and operational flight information and NOTAMs of the departure and destination aerodrome using a single data link service - Data link-Operational Terminal Information Service (D-OTIS).

At any time during the flight, the pilot may receive automatic updates of the meteorological data, operational information and NOTAMs of the destination or alternate aerodromes. D-OTIS may be tailored for the specific flight crew needs and so the pilot can readily form a picture from meteorological and operational perspectives.

### 1.4 Element 3: Departure Clearance (DCL)

The implementation of DCL eliminates potential misunderstandings due to VHF voice, hence enabling the ATC to provide a safer and more efficient service to their users. DCL also enables to reduce controllers' workload. DCL supports the airport system automation and information sharing with other ground systems.

For busy airports, the use of DCL data link results in a significant decrease in ATC tower frequency congestion. CPDLC systems that are integrated with FMS allow direct input of more complex clearances into the FMS.

### 1.5 Element 4: Data link TAXI (DTAXI)

This provides automated assistance and additional means of communication to controllers and pilots when performing routine communication exchanges during ground movement operations, Start-up, Pushback, Routine taxi messages and Special airport operations.

## 2. Intended Performance Operational Improvement

**Metrics to determine the success of the module are proposed in the *Manual on Global Performance of the Air Navigation System (Doc 9883)*.**

<i>Capacity</i>	Positively affected because of the reduction of workload associated to the establishment of the sequence close to the convergence point and related tactical interventions.  Positively affected because of the reduction of workload associated to the delivery of departure and taxi clearances.
<i>Efficiency</i>	Increased by using the aircraft RTA capability for traffic synchronization planning through en-route and into Terminal Airspace. "Closed loop" operations on RNAV procedures ensure common air and ground system awareness of traffic evolution and facilitate its optimization.  Flight efficiency is increased through proactive planning of top of descent, descent profile and en-route delay actions, and enhanced terminal airspace route efficiency.
<i>Environment</i>	More economic and environmentally friendly trajectories, in particular absorption of some delays.
<i>Predictability</i>	Increased predictability of the ATM system for all stakeholders through greater strategic management of traffic flow between and within <a href="#">FIRs</a> en-route and Terminal Airspace using the aircraft RTA capability or speed control to manage a ground CTA;  Predictable and repeatable sequencing and metering.  "Closed loop" operations on RNAV procedures ensuring common air and ground system awareness of traffic evolution.
<i>Safety</i>	Safety at/around airports by a reduction of the misinterpretations and errors in the interpretation of the complex departure and taxi clearances.

<a href="#">CBA</a>	Establishment of the business case is underway.  The Benefits of the proposed Airport services were already demonstrated in the EUROCONTROL CASCADE Programme.
---------------------	--

## 3. Necessary Procedures (Air & Ground)

New procedures have to be defined for the controller and pilot using extended phraseology and data link messages.



## 4. Necessary System Capability

### 4.1 Avionics

The necessary technology is defined in the EUROCAE WG78/RTCA SC 214 standards and comprises Airborne implementations of advanced datalink services (4DTRAD, D-Taxi, D-OTIS, ...) supported by CPDLC and ADS-C over ATN B2, and integrated with FMS

### 4.2 Ground Systems

For ground systems, the necessary functionalities include the ability to negotiate a time constraint over a given metering fix as well as to process the aircraft trajectory. Enhanced ground ground data interchange when available, will allow to share the common trajectory reference. It also includes the ability to facilitate the provision of start-up, push-back and taxi clearances via data link. Enhanced surveillance through multi-sensor data fusion is required.

## 5. Human Performance

### 5.1 Human Factors Considerations

**5.1.1** Data communications reduce the workload and the risk to misinterpret information in clearances, in particular when typing them in FMS. They allow reducing the congestion of the voice channel with overall understanding benefits and more flexible management of air-ground exchanges.

**5.1.2** Automation support is needed for both the pilot and the controller. Overall their respective responsibilities will not be affected.

**5.1.3** The identification of Human Factors considerations is an important enabler in identifying processes and procedures for this module. In particular, the human-machine interface for the automation aspects of this performance improvement will need to be considered and where necessary accompanied by mitigation risk mitigation strategies such as training, education and redundancy.

### 5.2 Training and Qualification Requirements

**5.2.1** Automation support is needed for both the pilot and the controller which therefore will have to be trained to the new environment and to identify the aircraft/facilities which can accommodate the data link services in mixed mode environments.

**5.2.2** Training in the operational standards and procedures will be identified along with the standards and recommended practices necessary for this module to be implemented. Likewise the qualifications requirements will be identified and included in the regulatory readiness aspects of this module when they become available.

## 6. Regulatory/standardization needs and Approval Plan (Air & Ground)

- **Regulatory/Standardization:** New or updated requirements for data link messages, ground services, operational procedures, etc are needed that includes:
  - ICAO Doc 9694, *Manual of Air Traffic Services Data Link Applications*;
  - RTCA/EUROCAE DO-XXXX/ED-XXXX, SC214/WG78 Enhanced [CPDLC](#) Message Set and ADS-C enhancements;
  - EC Regulation No. 29/2009: Datalink Services Implementing Rule.

Note: New ICAO OPLINK Ops Guidance under development

- **Approval Plans:** Publication of the EUROCAE WG78/RTCA SC 214 standards plus Air and ground certification and approvals to be determined.

## 7. Implementation and Demonstration Activities

### 7.1 Current Use

- **Europe** - Capability used ad hoc for tailored arrivals with RTA as well as arrival planning for Oceanic arrivals plus wide scale trials of point merge techniques now focused on deployment in European Terminal airspace and Approach areas with available [OSED](#) SPR material.
- **United States**: Domestic Airspace: Beginning in 2016 Departure Clearance Services will be deployed using [FANS-1/A+](#).
- **United States**: Oceanic Tailored Arrivals is currently operational in the US Coastal Aerodromes.

## 8. Reference Documents

### 8.1 Standards

- EUROCONTROL, Point Merge: Point Merge Integration of Arrival Flows Enabling Extensive RNAV Application and Continuous Descent. Operational Services and Environment Definition, July 2010
- EUROCAE ED-100A / RTCA DO-258A, Interoperability Requirements for ATS Applications using ARINC 622 Data Communications
- EUROCAE ED-110B / RTCA DO-280, Interoperability Requirements Standard for Aeronautical Telecommunication Network Baseline 1 (Interop ATN B1)
- EUROCAE ED-120 / RTCA DO-290, Safety and Performance Requirements Standard For Initial Air Traffic Data Link Services In Continental Airspace (SPR IC)
- EUROCAE ED-122 / RTCA DO-306, Safety and Performance Standard for Air Traffic Data Link Services in Oceanic and Remote Airspace (Oceanic SPR Standard)
- EUROCAE ED-154 / RTCA DO-305, Future Air Navigation System 1/A – Aeronautical Telecommunication Network Interoperability Standard (FANS 1/A – ATN B1 Interop Standard)
- EUROCAE WG-78 / RTCA SC-214 Safety and Performance requirements and Interoperability requirements.

### 8.2 Procedures

### 8.3 Guidance Material

- ICAO Doc 9694, *Manual of Air Traffic Services Data Link Applications*;
- New OPLINK Ops Guidance (under development);
- EUROCONTROL, 4DTRAD: Initial 4D – 4D Trajectory Data Link (4DTRAD) Concept of Operations, December 2008.

### 8.4 Approval Documents.

- ICAO Doc 9694, *Manual of Air Traffic Services Data Link Applications*;
- RTCA/EUROCAE DO-XXXX/ED-XXXX, SC214/WG78 Enhanced CPDLC Message Set and ADS-C enhancements;
- EC Regulation No. 29/2009: Datalink Services Implementing Rule;

Note: New ICAO OPLINK Ops Guidance under development.



## **Performance Improvement Area 4: Efficient Flight Path – Through Trajectory-based Operations.**

***Thread: Continuous Climb Operations***

This Page Intentionally Left Blank

## Module N° B0-20: Improved Flexibility and Efficiency Departure Profiles

<b>Summary</b>	To implement Continuous Climb Operations in conjunction with PBN to provide opportunities to optimize throughput, improve flexibility, enable fuel-efficient climb profiles and increase capacity at congested terminal areas.	
<b>Main Performance Impact</b>	KPA-04 – Efficiency; KPA-05 – Environment; KPA-10 - Safety	
<b>Operating Environment/Phases of Flight</b>	Departure and En-Route	
<b>Applicability Considerations</b>	<p>Regions, States or individual Locations most in need of these improvements. For simplicity and implementation success, complexity can be divided into three tiers:</p> <ol style="list-style-type: none"> <li>1. Least Complex – Regional/States/Locations with some foundational <a href="#">PBN</a> operational experience that could capitalize on near term enhancements, which include integrating procedures and optimizing performance.</li> <li>2. More Complex – Regional/States/Locations that may or may not possess PBN experience, but would benefit from introducing new or enhanced procedures. However, many of these locations may have environmental and operational challenges that will add to the complexities of procedure development and implementation.</li> <li>3. Most Complex – Regional/States/Locations in this tier will be the most challenging and complex to introduce integrated and optimized PBN operations. Traffic volume and airspace constraints are added complexities that must be confronted. Operational changes to these areas can have a profound effect on the entire State, Region or location.</li> </ol>	
<b>Global Concept Component(s)</b>	AUO – Airspace user operations TS – Traffic synchronization AOM – Airspace organization and management	
<b>Global Plan Initiatives (GPI)</b>	GPI 5- RNAV/RNP (Performance. Based Navigation) GPI-10- Terminal Area Design and Management GPI-11- RNP and RNAV SIDs and STARs	
<b>Pre-Requisites</b>	Linkage with B0-20	
		<b>Status (ready now or estimated date).</b>
<b>Global Readiness Checklist</b>	<i>Standards Readiness</i>	√
	<i>Avionics Availability</i>	√
	<i>Infrastructure Availability</i>	√
	<i>Ground Automation Availability</i>	√
	<i>Procedures Available</i>	√
	<i>Operations Approvals</i>	√

## 1. Narrative

### 1.1 General

This module integrates with other airspace and procedures (PBN, CDO, and Airspace Management) to increase efficiency, safety, access and predictability; and minimise fuel use, emissions, and noise.

As traffic demand increases, the challenges in terminal areas center on volume, convective weather, reduced-visibility conditions, adjacent airports and special activity airspace in close proximity whose procedures utilize the same airspace, and policies that limit capacity, throughput, and efficiency.

Environmental requirements must be taken into account. Apart from emissions, noise contours related to land planning requirements is part of the route design process laterally and vertically.

Traffic flow and loading (across ingress and egress routes) are not always well metered, balanced or predictable. Obstacle and airspace avoidance (in the form of separation minima and criteria), noise abatement procedures and noise sensitive areas, as well as wake encounter risk mitigation, tend to result in operational inefficiencies (e.g., added time or distance flown, thus more fuel).

Inefficient routing can also cause under-use of available airfield and airspace capacity. Finally, challenges are presented to States by serving multiple customers (international and domestic with various capabilities): the intermingling of commercial, business, general aviation and many times military traffic destined to airports within a terminal area that interact and at times inhibit each other's operations.

#### 1.1.1 Baseline

Flight operations in many terminal areas precipitate the majority of current airspace delays in many states. Opportunities to optimize throughput, improve flexibility, enable fuel-efficient climb and descent profiles, and increase capacity at the most congested areas should be a high-priority initiative in the near-term.

The baseline for this module may vary from one State, Region or location to the next. Noted is the fact that some aspects of the movement to PBN have already been the subject of local improvements in many areas; these areas and users are already realizing benefits.

The lack of an ICAO PBN operational approval guidance material and subsequently the emergence of States or regional approval material, which may differ or be even more demanding than intended, is slowing down implementation and is perceived as one of the main roadblocks for harmonization.

There is still some work to be done to harmonize PBN nomenclature, especially in charts and States/Regional regulations (e.g. most of European regulations still make use of [B-RNAV](#) and P-RNAV).

Efficiency of climb profiles may be compromised by level off segments, vectoring, and an additional overload of radio transmissions between pilots and air traffic controllers. Existing procedure design techniques do not cater for current FMS capability to manage the most efficient climb profiles. There is also excessive use of radio transmissions due to the need to vector aircraft in an attempt to accommodate their preferred trajectories.

#### 1.1.2 Change brought by the module

The core capabilities that should be leveraged are RNAV; [RNP](#) where possible and needed; continuous climb operations (CCO), increased efficiencies in terminal separation rules; effective airspace design and classification; and Air Traffic flow. Opportunities to reduce flight block times, fuel/emissions and aircraft noise impacts should also be leveraged where possible.

This module is a first step towards harmonization and a more optimized organization and management of the airspace. Many States will require knowledgeable assistance to achieve implementation. Initial implementation of PBN, RNAV for example, takes advantage of existing ground technology and avionics and allows extended collaboration of ANSPs with partners: military, airspace users, and neighbouring States. Taking small and required steps, and only performing what is needed or required allows States to rapidly exploit PBN.

#### 1.1.3 Other remarks

Operating at the optimum flight level is a key driver to improve flight fuel efficiency and minimising atmospheric emissions. A large proportion of fuel burn occurs in the climb phase and for a given route length, taking into account aircraft mass and the meteorological conditions for the flight, there will be an optimum flight level, which gradually increases as the fuel on-board is used up and aircraft mass therefore

reduces. Enabling the aircraft to reach and maintain its optimum flight level without interruption will therefore help to optimize flight fuel efficiency and reduce emissions.

CCO can provide for a reduction in noise, fuel burn and emissions, while increasing flight stability and the predictability of flight path to both controllers and pilots.

CCO is an aircraft operating technique aided by appropriate airspace and procedure design and appropriate ATC clearances enabling the execution of a flight profile optimized to the operating capability of the aircraft, thereby reducing fuel burn and emissions during the climb portion of flight.

The optimum vertical profile takes the form of a continuously climbing path, with a minimum of level flight segments only as needed to accelerate and configure the aircraft.

The optimum vertical path angle will vary depending on the type of aircraft, its actual weight, the wind, air temperature, atmospheric pressure, icing conditions and other dynamic considerations.

A CCO can be flown with or without the support of a computer-generated vertical flight path (i.e. the vertical navigation (VNAV) function of the flight management system (FMS)) and with or without a fixed lateral path. The maximum benefit for an individual flight is achieved by allowing the aircraft to climb on the most efficient climb profile along the shortest total flight distance possible.

## 2. Intended Performance Operational Improvement

<i>Efficiency</i>	<p>Cost savings through reduced fuel burn and efficient aircraft operating profiles.</p> <p>Reduction in the number of required radio transmissions.</p>
<i>Environment</i>	<p>Authorization of operations where noise limitations would otherwise result in operations being curtailed or restricted.</p> <p>Environmental benefits through reduced emissions.</p>
<i>Safety</i>	<p>More consistent flight paths.</p> <p>Reduction in the number of required radio transmissions.</p> <p>Lower pilot and Air Traffic Control workload.</p>
<u>CBA</u>	<p>It is important to consider that <u>CCO</u> benefits are heavily dependent on each specific ATM environment.</p> <p>Nevertheless, if implemented within the ICAO CCO manual framework, it is envisaged that the benefit/cost ratio (BCR) will be positive.</p>

## 3. Necessary Procedures (Air & Ground)

The ICAO Performance-based Navigation Manual (ICAO Document 9613) provides general guidance on PBN implementation.

This manual identifies the relationship between RNAV and RNP applications and the advantages and limitations of choosing one or the other as the navigation requirement for an airspace concept.

It also aims at providing practical guidance to States, air navigation service providers and airspace users on how to implement RNAV and RNP applications, and how to ensure that the performance requirements are appropriate for the planned application.

The ICAO *Continuous Climb Operations (CCO)* Manual (Doc xxxx) provides guidance on the airspace design, instrument flight procedures, ATC facilitation and flight techniques necessary to enable continuous descent profiles.

It therefore provides background and implementation guidance for:

- a) air navigation service providers;
- b) aircraft operators;

- c) airport operators; and
- d) aviation regulators.

## 4. Necessary System Capability

### 4.1 Avionics

CCO does not require a specific air or ground technology. It is an aircraft operating technique aided by appropriate airspace and procedure design, and appropriate ATC clearances enabling the execution of a flight profile optimized to the operating capability of the aircraft, in which the aircraft can attain cruise altitude flying at optimum air speed with climb engine thrust settings set throughout the climb, thereby reducing total fuel burn and emissions during the whole flight. Reaching cruise flight levels sooner where higher ground speeds are attained can also reduce total flight block times. This may allow a reduced initial fuel upload with further fuel, noise and emissions reduction benefits.

The optimum vertical profile takes the form of a continuously climbing path. Any level or non-optimal reduced climb rate segments during the climb to meet aircraft separation requirements should be avoided. Achieving this whilst also enabling Continuous Descent Operations (CDO) is critically dependent upon the airspace design and the height windows applied in the instrument flight procedure. Such designs need an understanding of the optimum profiles for aircraft operating at the airport to ensure that the height windows avoid, to greatest extent possible, the need to resolve potential conflicts between the arriving and departing traffic flows through ATC height or speed constraints.

### 4.2 Ground systems

Controllers would benefit from some automation support to display aircraft capabilities in order to know which aircraft can do what.

## 5. Human Performance

### 5.1 Human Factors Considerations

**5.1.1** Human Factors have been taken into consideration during the development of the processes and procedures associated with this module. Where automation is to be used, the Human-Machine interface has been considered from both a functional and ergonomic perspective (See Section 6 for examples). The possibility of latent failures however, continues to exist and vigilance is requested during all implementation actions. It is further requested that human factor issues, identified during implementation, be reported to the international community through ICAO as part of any safety reporting initiative.

### 5.2 Training and Qualification Requirements

**5.2.1** Training in the operational standards and procedures are required for this module and can be found in the links to the documents in Section 8 to this module. Likewise, the qualifications requirements are identified in the regulatory requirements in Section 6 which form an integral part to the implementation of this module.

## 6. Regulatory/standardization needs and Approval Plan (Air and Ground)

- **Regulatory/Standardization:** Use current published requirements that includes the material given in Section 8.4.
- **Approval Plans:** Must be in accordance with application requirements.

**Discussion:** Understanding the policy context is important for making the case for local [CCO](#) implementation and ensuring high levels of participation. CCO may be a strategic objective at international, State, or local level, and as such, may trigger a review of airspace structure when combined with [CDO](#).

For example, noise contour production may be based on a specific departure procedure (NADP1 or NADP2-type). Noise performance can be improved in some areas around the airport, but it may affect existing noise contours elsewhere. Similarly CCO can enable several specific strategic objectives to be met and should therefore be considered for inclusion within any airspace concept or redesign. Guidance on airspace concepts and strategic objectives is contained in Doc 9613. Objectives are usually collaboratively identified by airspace users, ANSPs, airport operators as well as by government policy. Where a change could have an impact on the environment, the development of an airspace concept may involve local communities,

planning authorities and local government and may require formal impact assessment under regulations. Such involvement may also be the case in the setting of the strategic objectives for airspace. It is the function of the airspace concept and the concept of operations to respond to these requirements in a balanced, forward-looking manner, addressing the needs of all stakeholders and not of one of the stakeholders only (e.g. the environment). Doc 9613, Part B, Implementation Guidance, details the need for effective collaboration among these entities

Contrary to a CDO, where noise benefits are an intrinsic positive element, in case of a CCO, the choice of a departure procedure (NADP1 or NADP2-type), requires a decision of the dispersion of the noise. In addition to a safety assessment, a transparent assessment of the impact of CCO on other air traffic operations and the environment should be developed and made available to all interested parties.

## **7. Implementation and Demonstration Activities**

### **7.1 Current Use**

- **United States** – Procedures are currently being developed to incorporate Optimized Climb Profiles as part of procedure and airspace development.

### **7.2 Planned or Ongoing Activities**

- **United States** – None at this time.

## **8. Reference Documents**

### **8.1 Standards**

### **8.2 Procedures**

- ICAO Doc 4444, *Procedures for Air Navigation Services — Air Traffic Management.Guidance Material*;
- ICAO Doc 9613, *Performance-based Navigation (PBN) Manual*;
- ICAO Doc xxxx, *Continuous Climb Operations (CCO) Manual (under development)*.

### **8.3 Approval Documents**

- ICAO Doc XXXX, *Continuous Climb Operations Manual*;
- ICAO Doc 9613, *Performance Based Navigation Manual*;
- ICAO Doc 4444, *Procedures for Air Navigation Services — Air Traffic Management*.

## **Performance Improvement Area 4: Efficient Flight Path – Through Trajectory-based Operations.**

***Thread: Remotely Piloted Aircraft***



This Page Intentionally Left Blank

## Module N° B1-90 Initial Integration of Remotely-Piloted Aircraft (RPA) Systems into non-segregated airspace

<b>Summary</b>	Implementation of basic procedures for operating RPA in non-segregated airspace including detect and avoid.	
<b>Main Performance Impact</b>	KPA-01 Access & Equity, KPA-10 Safety,	
<b>Operating Environment/Flight Phases</b>	En-route, oceanic, terminal (arrival and departure), aerodrome (taxi, take-off and landing)	
<b>Applicability Considerations</b>	Applies to all RPAS operating in controlled airspace and at aerodromes. Requires good synchronization of airborne and ground deployment to generate significant benefits, in particular to those able to meet minimum certification and equipment requirements.	
<b>Global Concept Component(s)</b>	AOM - Airspace Organization and Management CM - Conflict Management AUO - Airspace User Operations	
<b>Global Plan Initiatives (GPI)</b>	GPI-6, Air traffic flow management GPI-9, Situational awareness GPI-12, Functional integration of ground systems with airborne systems GPI-17, Data link applications	
<b>Main Dependencies</b>	NIL	
<b>Global Readiness Checklists</b>		<b>Status</b> (ready now or estimated date).
	Standards Readiness	Est. 2018
	Avionics Availability	Est. 2018
	Ground Systems Availability	Est. 2018
	Procedures Available	Est. 2018
Operations Approvals	Est. 2018	

### 1. Narrative

#### 1.1 General

This module will discuss the baseline from which the further improvements discussed will be based. The aim is to move from initial accommodation of RPA, to integration into traffic within controlled airspace and at controlled aerodromes, and finally to full transparent operation within the airspace. Block 1 is the first step in this process. The Block 1 improvements are:

- Streamline process to access non-segregated controlled airspace
- Define airworthiness certification for RPA
- Define operator certification
- Define remote pilot licensing requirements
- Define detect and avoid technology performance requirements

The United States, specifically the FAA, is in the review process for defining “small UAS” procedures: Once small UAS procedures are approved, small UAS operations in the U.S., outside of military operating areas may be permitted, first in unpopulated, then sparsely populated areas. Small UAS policy will be based on the successive expansions of use and the rules and procedures that are established. These small UAS procedures will continue to be developed to allow small UAS to operate in more types of airspace. VLOS will be used to provide detect and avoid mitigation for these UAS. This is a U.S.-focused approach that currently may not apply for other States.

Some States are looking at localized ground-based detect and avoid (GBDAA) technology to support the detect and avoid requirements.

Below is a list of definitions that are used in this module.

- **Command and control (C2) link.** The data link between the remotely-piloted aircraft and the remote pilot station for the purposes of managing the flight.
- **Controlled airspace.** An airspace of defined dimensions within which air traffic control service is provided in accordance with the airspace classification.
- **Segregated airspace.** Airspace of specified dimensions allocated for exclusive use to a specific user(s).
- **Detect and avoid.** The capability to see, sense or detect conflicting traffic or other hazards and take the appropriate action.
- **Remote pilot.** A person charged by the operator with duties essential to the operation of a remotely-piloted aircraft and who manipulates the flight controls, as appropriate, during flight time.
- **Remote pilot station.** The component of the remotely-piloted aircraft system containing the equipment used to pilot the remotely-piloted aircraft.
- **Remotely-piloted aircraft (RPA).** An unmanned aircraft which is piloted from a remote pilot station.
- **Remotely-piloted aircraft system (RPAS).** A remotely-piloted aircraft, its associated remote pilot station(s), the required command and control links, and any other components as specified in the approved type design.
- **RPA observer.** A trained and competent person designated by the operator who, by visual observation of the remotely-piloted aircraft, assists the remote pilot in the safe conduct of the flight.
- **Visual line-of-sight (VLOS) operation.** An operation in which the remote pilot or RPA observer maintains direct visual contact with the remotely-piloted aircraft.

### 1.1.1. Baseline

The baseline for this module is a situation where RPA are only used in segregated airspace.

### 1.1.2 Change brought by the module

The module provides for the implementation of basic procedures for operating RPA in non-segregated controlled airspace including detect and avoid. This includes the following actions:

**Streamline process to access non-segregated controlled airspace.** State authorities will need to consider if current national/regional processes are adequate for enabling the level of airspace access necessary to accomplish all missions proposed or envisioned for RPA flights. While international RPAS standards and certification requirements are being developed, national and/or regional authorization processes will be used to access airspace. Methods for improving and streamlining these processes will be worked on during this time frame. Approval to use existing technologies, such as ground-based detect and avoid systems, may support access to airspace through enhanced collision avoidance capability. This will allow authorities to streamline the process to grant authorization for airspace access.

**Defining airworthiness certification for RPA:** Standards committees (such as RTCA SC-203, ASTM F 38, EUROCAE WG 73, and others) will continue their work in the Block 1 timeframe, developing minimum aviation system performance standards (MASPS). Certification takes into account system configuration, usage, environment, and the hardware and software of the entire system (e.g. aircraft, remote pilot stations, C2 links). It also considers design characteristics, production processes, reliability, and in-service maintenance procedures that adequately mitigate risk of injury/damage to people, property or other aircraft. EASA's Rulemaking Directorate has issued policy statement E. Y013-01 for Airworthiness Certification of RPAS that outlines procedures for type certification of civil RPA once standards have been established. Technical standards might be used to certify specific components of the RPAS. The certificate of Airworthiness will be issued to the aircraft while considering the entire system. The C2 links will have to meet identified performance requirements. Certification standards and procedures will need to be worked out during this time frame.

**Define operator certification:**

To be determined.

**Define communication** performance requirements to support command and control (C2) and [ATC](#) communications. These performance-based requirements will be developed and certified to support the RPAS operational improvements. The technology needs to support all aspects of removing the pilot from the aircraft such as the ability to manage the trajectory of the RPA display of the on-board avionics. The security of the C2 data links must be assured for all operations beyond line of sight. Likewise performance requirements related to reliability, availability and latency will need to be developed.

**Define remote pilot licensing requirements:**

(This is being worked on by UASSG, EASA and some States) TBD

**Define detect and avoid** technology performance requirements. These performance-based requirements will be developed and certified to support the RPAS operational improvements as discussed above. The technology will be developed in conjunction with other risk mitigation efforts to gain incremental access to the airspace. Initial capabilities may include ground-based detect and avoid systems consisting of any combination of policy, procedures, and technology derived from ground-based sensors intended to facilitate safe airspace access over land or water. Surveillance (radar, ADS-B) initiatives will help gather, test, and verify data, along with the appropriate modeling and simulation activities, to establish requirements and build an overall safety case for detect and avoid. The detect and avoid technology will be used by the remote pilot to meet collision and hazard avoidance responsibility and provide situational awareness.

**2. Intended Performance Operational Improvement**

**Metrics to determine the success of the module are proposed in the *Manual on Global Performance of the Air Navigation System (Doc 9883)*.**

<i>Access and Equity</i>	
<i>Safety</i>	Increased situational awareness; controlled use of aircraft

<a href="#"><u>CBA</u></a>	The business case is directly related to the economic value of the aviation applications supported by RPAS.
----------------------------	---

**3. Necessary Procedures (Air & Ground)**

It is anticipated that as the improvements take shape in this block, air traffic services and procedures will have to change to accommodate these new airspace users. RPAS procedures such as C2 link failure will need to be standardized. These procedures may include a specific transponder code or [ADS-B](#) emergency mode to indicate a C2 link failure.

**4. Necessary System Capability (Air & Ground)**

**4.1 Avionics**

Communications includes traditional voice/data communications as well as all data related to command and control of the RPA. Current air-to-ground communications networks presume the pilot is on board the aircraft. The implications of the remote pilot being external to the aircraft will require a review and revision to preferred communications networks as well as bandwidth to support the amount of data required to operate and manage the RPA (STANAG 4586).

**4.2 Ground Systems**

Ground-based Detect and Avoid (GBDAA) is the technology in this time frame envisioned to afford the greatest return on investment to allow better access to non-segregated airspace. This technology will improve the “detect and avoid” situational awareness for the remote pilot within the specific coverage areas defined by the systems and has the potential to be the near/midterm solution to the detect and avoid problem plaguing the RPAS community. This approach is currently utilized on a limited basis and may become a global approach in this time frame.

## 5. Human Performance

### 5.1 Human Factors Considerations

**5.1.1** The controller-pilot relationship is changing and will need to be investigated. Specific training for controllers, remote pilots and pilots will be required, in particular with respect to the new detect and avoid situations.

**5.1.2** The identification of Human Factors considerations is an important enabler in identifying processes and procedures for this module. In particular, the human-machine interface for the automation aspects of this performance improvement will need to be considered and where necessary accompanied by mitigation risk mitigation strategies such as training, education and redundancy.

### 5.2 Training and Qualification Requirements

**5.2.1** Training in the operational standards and procedures will be identified along with the standards and recommended practices necessary for this module to be implemented. Likewise the qualifications requirements will be identified and included in the regulatory readiness aspects of this module when they become available.

## 6. Regulatory/standardization needs and Approval Plan (Air & Ground)

- **Regulatory/Standardization: New or updated requirements for RPA operations are needed that includes:**
  - ICAO PANS-ATM
  - Ops Approval Guidance for Certificate of airworthiness, Operator certificate, Remote pilot licence, Frequency spectrum, Communications (including C2 link failure) and Detect and avoid
- **Approval Plans:** To Be Determined covering the following areas:
  - RPAS approval
  - Certificate of airworthiness
  - Operator certificate
  - Remote pilot licence
  - Frequency spectrum
  - Communications (including C2 link failure)
  - Detect and avoid

## 7. Implementation and Demonstration Activities

### 7.1 Current Use

- 4.1.1 United States:** The baseline is currently being used in the U.S. The Army has an authorization for ground-based sense and avoid (GBSAA) operations of their Medium/Large RPA, the Sky Warrior (Predator variant) at El Mirage, CA. The Marines/Navy are in the process of getting authorization for GBSAA operations at Cherry Point, SC. The USAF is looking at a corridor for Predator/Reaper aircraft climbing out of Cannon AFB, NM. This GBSAA concept will include a 12 NM corridor between the military Class D airspace and nearby restricted airspace. By 2013, the USAF will have developed a Dynamic Protection Zone (DPZ) concept that will shrink these large exclusion zones down to non-cooperative aircraft self-separation criteria of less than 10 NM much like is used for cooperative aircraft flying under [IFR](#) today.

**Europe:**

- EUROCONTROL is in the process of integrating an RPA in Class C and D airspace under IFR and VFR. Detect and avoid is mitigated through GBDAA and scanning through the on-board camera system. This will enable further integration.
- The MIDCAS consortium is developing a detect and avoid test bed that should be available for testing beginning in 2012
- In regard to VLOS, the Netherlands will certify an RPAS this year (civil certified)
- Euro Hawk is flying in controlled airspace as “operational air traffic”
- EUROCAE has finalized their work on a guidance document for VLOS
- A strategy document outlining EC policy on UAS is in preparation through an EC UAS panel, addressing industry and market issues, UAS insertion and spectrum, safety, societal dimensions and R&D
- Legal framework for the development of [AMC](#) is in place. EASA will only deal with UAS with a mass greater than 150 kg.

**7.2 Planned or On Going Trials**

- In the US and Europe, several civil applications, initially VLOS and more integration of civil IFR/VFR operations in this time frame are expected based on full certification and special authorization
- US – Demonstrating enhanced voice communications through a Digital Network Radio System, the use of surveillance information on a CDTI in 2012.
- Requirements for frequency spectrum for RPAS will be established in this time frame
- SESAR addresses UAS within WP 9, 11 and 15
- The European Defence Agency has launched the MIDCAS project. It is addressing detect and avoid from both military and civil perspectives. The budget is 50 million Euros and it is expected to produce a working prototype for detect and avoid application by the end of 2013.
- Mercator, an ultra-light UAS that is solar/battery powered for long duration flights at around FL450 is being tested in Belgian airspace to demonstrate a UAS flight in a busy ATM environment.

**8. Reference Documents****8.1 Standards**

- ICAO Annex 2 — *Rules of the Air* (proposal for amendment);
- ICAO Annex 7 — *Aircraft Nationality and Registration Marks* (proposal for amendment);
- ICAO Circ 328, *Unmanned Aircraft Systems (UAS)*;
- U.S. Department of Transportation FAA, Air Traffic Organization Policy N JO 7210.766;
- NATO STANAG 4586, *Standard Interfaces of UAV Control System (UCS) for NATO UAV Interoperability*.

**8.2 Procedures****8.3 Guidance Material**

- EUROCAE Document (under development).

**8.4 Approval Documents**

- ICAO PANS-ATM;
- New Ops Approval Guidance material needed for Certificate of airworthiness, Operator certificate, Remote pilot licence, Frequency spectrum, Communications (including C2 link failure) and Detect and avoid.

# Module N° B2-90: Remotely Piloted Aircraft (RPA) Integration in Traffic

<b>Summary</b>	Continuing to improve the RPA access to non-segregated airspace; continuing to improve the RPAS certification process; continuing to define and refine the RPAS operational procedures, standardizing the C2 link failure procedures and agreeing on a unique squawk code for C2 link failure; and working on detect and avoid technologies, to include <a href="#">ADS-B</a> and algorithm development to integrate RPA into the airspace.	
<b>Main Performance Impact</b>	KPA-01 Access & Equity, KPA-10 Safety	
<b>Operating Environment/Flight Phases</b>	All phases of flight including taxi	
<b>Applicability Considerations</b>	Applies to all RPA operating in controlled airspace and at aerodromes. Requires good synchronization of airborne and ground deployment to generate significant benefits, in particular to those able to meet minimum certification and equipment requirements.	
<b>Global Concept Components</b>	AOM - Airspace Organization and Management CM - Conflict Management AUO - Airspace User Operations	
<b>Global Plan Initiatives (GPI)</b>	GPI-9, Situational awareness GPI-12, Functional integration of ground systems with airborne systems GPI-17, Data link applications	
<b>Main Dependencies</b>	B1-90	
<b>Global Readiness Checklist</b>		<b>Status</b> (indicate ready with a tick or input date)
	Standards Readiness	Est. 2023
	Avionics Availability	Est. 2023
	Ground Systems Availability	Est. 2023
	Procedures Available	Est. 2023
	Operations Approvals	Est. 2023

## 1. Narrative

### 1.1 General

Based on Block 1, initial integration of RPA in non-segregated airspace, Block 2 includes the procedures and technology that are possible in the block 2 timeframe.

				<b>Class D, E, F, and G</b>
				Operations not permitted, unless by waiver or authorization





- **Revised separation criteria and/or handling procedures (i.e. moving airspace)**
- **ADS-B on most RPA classes:** It is envisioned that ADS-B will be included on most new RPA being built during this time period and a retrofit program should be established for older aircraft.
- **Communication** performance requirements to support command and control (C2) and ATC communications will be refined. Security, reliability, availability and latency requirements will be increased to match the greater level of airspace access RPA are granted.
- **Detect and Avoid technologies** will be improved and certified to support RPA and operational improvements. Ground Based Detect and Avoid (GBDAA) will be certified and approved for more pieces of airspace. Other approaches to consider include an on-board (airborne) detect and avoid solution (ABDAA). ABDAA efforts are currently focused on developing the capability to perform both self-separation and collision avoidance on board the aircraft that ensure an appropriate level of safety even in the event of command and control link failure. The initial capability will provide an ability to collect and analyze valuable data for developing a robust airborne DAA system.
- **Protected spectrum and security**<sup>3</sup> this necessitates the use of designated frequency bands, i.e. those reserved for aeronautical safety and regularity of flight under Aeronautical Mobile (route) Service (AM(R)S), Aeronautical Mobile Satellite (route) Service (AMS(R)S), Aeronautical Radio Navigation Service (ARNS) and Aeronautical Radio Navigation Satellite Service (ARNSS) allocations as defined in the ITU Radio Regulations. It is essential that any communications between the RPS and RPA for C2 meet the performance requirement applicable for that airspace and/or operation, as determined by the appropriate authority. SATCOM links may require a backup.

This might lead to a utilization scheme, still to be discussed and validated, as follows:

Block 2	Class B and C	Class A Airspace (Other than High Seas)	High Seas (Class A Airspace)	Class D, E, F, and G
<b>Authorization</b>	Strict compliance with the provisions of the authorization is required			Operations not permitted, unless by waiver or authorization
<b>C2 Link Failure Procedures</b>	Will follow standardized procedures. A special purpose transponder code will be established.	Will follow standardized procedures.		
<b>Communications</b>	Continuous two-way communications as required for the airspace. RPA will squawk 7600 in case of communication failure.	Continuous two-way communications will be maintained directly or via a service provider (e.g. ARINC or SITA) depending on location and operation.		
<b>Separation Minima</b>	New separation minima may be required	Separation criteria will be analyzed and special separation criteria might be developed.		
<b>ATC Instructions</b>	RPAS will comply with ATC instructions as required			
<b>RPA Observers</b>	As required for the operation			
<b>Medical</b>	Remote pilots shall have an appropriate medical certificate			
<b>Presence of Other Aircraft</b>	RPAS shall not increase safety risk to the air navigation system			
<b>Visual Separation</b>	Visual separation may be permitted.	TBD		
<b>Responsibility of Remote Pilot</b>	Remote pilot is responsible for compliance with the rules of the air and adherence with the authorization			
<b>Populated Areas</b>	Restrictions to be determined by the State.			
<b>ATC Services</b>	Consistent with Annex 11,			

<sup>3</sup> ICAO Cir 328 An/190 Unmanned Aircraft Systems (UAS)

<b>Flight Plan</b>	RPAS operations, except VLOS, shall be conducted in accordance with <a href="#">IFR</a> . Flight plans shall be filed.	
<b>Meteorological Conditions</b>	Restrictions to be determined by the State	
<b>Transponder</b>	Shall have and use an operating mode C/S transponder	
<b>Safety</b>	Identify the hazards and mitigate the safety risks; adhere to the authorization	
<b>NOTAMs</b>	NOTAM requirements, if any, to be determined by the State	
<b>Certification</b>	TBD	

**2. Intended Performance Operational Improvement**

Metrics to determine the success of the module are proposed in the *Manual on Global Performance of the Air Navigation System (Doc 9883)*.

<i>Access and Equity</i>	Access to airspace by a new category of users.
<i>Safety</i>	Increased situational awareness; controlled use of aircraft

<a href="#">CBA</a>	The business case is directly related to the economic value of the aviation applications supported by RPAS.
---------------------	---

**3. Necessary Procedures (Air & Ground)**

Improved air traffic management (ATM) procedures will need to be in place to allow the access of RPA's into the non-segregated airspace. Specifically:

- ATM provisions need to be amended to accommodate the RPA taking into account the unique operational characteristics of each RPA type as well as their automation and non-traditional IFR/VFR capabilities,
- Air navigation service providers will need to review emergency and contingency procedures to take account of unique RPA failure modes such as C2 link failure, to include standardized procedures, and a new special purpose transponder code. Also consider procedures that may be necessary if the RPA is using an alternate C2 link that results in excessive delay in responding to RPA pilot inputs,
- Terminal areas will need to improve their procedures to allow for the increased volume of RPA activity,
- Ground operations will need to be modified to accommodate the increased activity of RPA's as well.

Improved RPA certification procedures will need to be developed, as well as standardizing the C2 link failure procedures. As [ABDAA](#) algorithms are developed, associated RPA operations procedures will need to be developed.

**4. Necessary System Capability (Air & Ground)**

**4.1 Avionics**

- [ADS-B](#) out (Jordan) on most RPA as well as all manned aircraft
- Preliminary development and testing of airborne detect and avoid technologies

**4.2 Ground Systems**

- GBDAA where applicable
- ATC automation will need to be able to respond to this new lost link code
- Automatic position reporting to ATC capability for C2 link failure over high seas

## 5. Human Performance

### 5.1 Human Factors Considerations

5.1.1 The controller-pilot relationship is changing and will need to be investigated. Specific training for controllers, remote pilots and pilots will be required, in particular with respect to the new detect and avoid situations.

5.1.2 This module is still in the research and development phase so the human factors considerations are still in the process of being identified through modelling and beta testing. Future iterations of this document will become more specific about the processes and procedures necessary to take the human factors considerations into account. There will be a particular emphasis on identifying the human-machine interface issues if there are any and providing the high risk mitigation strategies to account for them.

### 5.2 Training and Qualification Requirements

5.2.1 This module will eventually contain and number of personnel training requirements. As and when they are developed, they will be included in the documentation supporting this module and their importance signified. Likewise, any qualifications requirements that are recommended will become part of the regulatory needs prior to implementation of this performance improvement.

## 6. Regulatory/standardization needs and Approval Plan (Air & Ground)

- **Regulatory/Standardization:** New or updated requirements and standards are needed that includes:
  - C2 link failure standards and procedures.
  - Specific special purpose transponder code for C2 link failure.
  - Updated ATM procedures to allow for the integration of RPA into en-route and terminal airspace.
  - Update airworthiness standards and procedures.
- **Approval Plans:** To Be Determined

## 7. Implementation and Demonstration Activities

### 7.1 Current Use

### 7.2 Planned or On Going Trials

- **Europe:** So far all strategies are aimed at full integration within the timeframe of Block 2. SESAR will address this. ADS-B and Satcom are on the agenda. Integrated RPA/manned airport operations. Separation and airspace safety panel (SASP) will make determination on separation minima that will be applicable.
- **United States:** Demonstrating the capability to integrate RPA into the [NAS](#) using ADS-B and Addressable Voice over [IP](#) communications.

## 8. Reference Documents

### 8.1 Standards

- ICAO Annex 2 — *Rules of the Air*; (proposal for amendment);
- ICAO Annex 7 — *Aircraft Nationality and Registration Marks* (proposal for amendment);
- ICAO Circular 328 — *Unmanned Aircraft Systems (UAS)*;
- U.S. Department of Transportation FAA, Air Traffic Organization Policy, N JO 7210.766;
- NATO STANAG 4586, Standard Interfaces of UAV Control System (UCS) for NATO UAV Interoperability;

- EUROCAE Document (under development).

## **8.2 Procedures**

## **8.3 Guidance Material**

## **8.4 Approval Documents**

New Material is needed for the following:

- C2 link failure standards and procedures;
- Specific special purpose transponder code for C2 link failure;
- Updated ATM procedures to allow for the integration of RPA into en-route and terminal airspace;
- Updated airworthiness standards and procedures.

## Module N° B3-90: Remotely Piloted Aircraft (RPA) Transparent Management

<b>Summary</b>	Continuing to improve the certification process for RPA in all classes of airspace, working on developing a reliable C2 link, certifying autonomous responses to potential incursions, developing and certifying Airborne Detect and Avoid (ABDAA) algorithms, and integration of RPA into aerodrome procedures.	
<b>Main Performance Impact</b>	KPA-01 Access & Equity, KPA-02 Capacity; KPA-05 Environment, KPA-09 Predictability, KPA-10 Safety	
<b>Operating Environment Flight Phases</b>	En-route, oceanic, terminal (arrival and departure), aerodrome (taxi, take-off and landing)	
<b>Applicability Considerations</b>	Applies to all RPA operating in controlled airspace and at aerodromes. Requires good synchronization of airborne and ground deployment to generate significant benefits, in particular to those able to meet minimum certification and equipment requirements.	
<b>Global Concept Component(s)</b>	AOM - Airspace Organization and Management CM - Conflict Management AUO - Airspace User Operations	
<b>Global Plan Initiatives (GPI)</b>	GPI-6, Air traffic flow management GPI-9, Situational awareness GPI-12, Functional integration of ground systems with airborne systems	
<b>Pre-Requisites</b>	B2-90	
<b>Global Readiness Checklist</b>		<b>Status</b> (indicate ready with a tick or input date)
	Standards Readiness	Est. 2028
	Avionics Availability	Est. 2028
	Ground Systems Availability	Est. 2028
	Procedures Available	Est. 2028
	Operations Approvals	Est. 2028

### 1. Narrative

#### 1.1 General

##### 1.1.1 Baseline

The baseline contains procedures that accommodate and allow for the evolution of RPA into the airspace. This includes the improvements addressed in Block 2-90, which are:

- Access to most airspace for select airframes without specific authorization or experimental aircraft waiver
- RPA certification procedures
- RPAS approval procedures
- New special purpose transponder code for C2 link failure
- Standardized C2 link failure procedures
- Revised separation criteria and/or handling procedures (i.e. moving airspace)
- ADS-B on most RPA classes
- Detect and Avoid technologies improvements
- Automatic position reporting to ATC capability for C2 link failure over high seas



- Rescue and fire fighting requirements for RPA (and remote pilot station, if applicable)
- RPA launch/recovery at sites other than aerodromes
- Integration of RPA with manned aircraft in the vicinity of an aerodrome
- Aerodrome implications for RPAS-specific equipment (e.g. remote pilot stations)

This might lead to a utilization scheme, still to be discussed and validated, as follows:

Block 3	Fully Controlled Terminal En Route Class A Airspace	High Seas Class A Airspace	Uncontrolled and Partially Controlled Airspace (Class D, E, F, and G)
<b>Authorization</b>	Strict compliance with standard regulations is required.		
<b>C2 Link Failure Procedures</b>	Shall follow standardized procedures. A special purpose transponder code will be established.	Shall follow standardized procedures. Must broadcast or contract position reports to <a href="#">ATC</a>	RPA must be equipped for Air born Detect and avoid in case a C2 link failure is experienced during flight
<b>Communications</b>	Continuous two-way communications as required for the airspace. RPA will squawk 7600 in case of communications failure.	Primary communications are via terrestrial data link; for communications failure RPA pilot will use telephonic communications. RPA will be capable of air-to-air communications.	N/A
<b>Separation Minima</b>	New separation minima may be required		RPAS is responsible for maintaining safe separation
<b>ATC Instructions</b>	RPAS will comply with ATC instructions as required		N/A
<b>RPA Observers</b>	Not required if RPAS is equipped for GBDAA flight in a GBDAA approved area, or is equipped for <a href="#">ABDAA</a>	Not required	N/A
<b>Medical</b>	Remote pilots shall have an appropriate medical certificate		
<b>Presence of Other Aircraft</b>	RPA shall not increase safety risk to the air navigation system		
<b>Visual Separation</b>	Visual separation will be permitted if RPAS is equipped for GBDAA flight in a GBDAA approved area, or is equipped for <a href="#">ABDAA</a>	TBD	RPA must use GBDAA or <a href="#">ABDAA</a> for separation at all times
<b>Responsibility of Remote Pilot</b>	Remote pilot is responsible for compliance with the rules of the air and adherence with the authorization		
<b>Populated Areas</b>	RPAS shall not conduct operations over populated areas (terminal airspace is often/usually in populated areas)	Operations over populated areas permitted if there is sufficient height to glide to an unpopulated area in an emergency	RPAS shall not conduct operations over populated areas
<b>ATC Services</b>	Consistent with Annex 11, Appendix 4		N/A
<b>Flight Plan</b>	RPA operations will be conducted on an <a href="#">IFR</a> or VFR flight plan. VFR flight plans will only be conducted if the RPAS is equipped for GBDAA flight in a GBDAA approved area, or is equipped		

	for <a href="#">ABDAA</a> .
<b>Meteorological Conditions</b>	Restrictions to be determined by the State
<b>Transponder</b>	Shall have and use <a href="#">ADS-B</a> N/A
<b>Safety</b>	Identify the hazards and mitigate the safety risks; adhere to the authorization
<b>NOTAMs</b>	NOTAM requirements, if any, to be determined by the State
<b>Certification</b>	TBD

## 2. Intended Performance Operational Improvement

Metrics to determine the success of the module are proposed in the *Manual on Global Performance of the Air Navigation System (Doc 9883)*.

<i>Capacity</i>	Could be negatively impacted due to larger separations being applied for safety reasons between RPA and traditional traffic.
<i>Access and Equity</i>	Transparent access to airspace by RPAS
<i>Environment</i>	The uniform application of the module increases global interoperability by allowing pilots and remote pilots to be faced with understandable situations when flying in different States.
<i>Predictability</i>	Increased predictability of RPA through global interoperability of communications and situational awareness.
<i>Safety</i>	Increased situational awareness; controlled use of aircraft

<a href="#">CBA</a>	The business case is directly related to the economic value of the aviation applications supported by RPAS.
---------------------	---

## 3. Necessary Procedures (Air & Ground)

- ATM procedures for RPAS to operate in all classes of airspace
- Procedures that allow for multiple RPA in the same airspace at the same time
- Procedures that allow RPA to operate out of all classes of airports
- Procedures that allow for autonomous operations including autonomous responses in specific situations
- Where RPA are operating alongside manned aircraft ground and air procedures that insure harmonized operations are needed.

## 4. Necessary System Capability (Air & Ground)

### 4.1 Avionics

- Certified [ABDAA](#) algorithms
- Reliable C2 links
- Equipage of all aircraft, with proven detect and avoid technology
- Equipage of RPAS with necessary equipment to work within existing aerodrome parameters to the greatest extent practicable.

### 4.2 Ground Systems

- GBDAA to supplement where applicable
- Certified autonomous algorithms



## **5. Human Performance**

### **5.1 Human Factors Considerations**

**5.1.1** This module is still in the research and development phase so the human factors considerations are still in the process of being identified through modelling and beta testing. Future iterations of this document will become more specific about the processes and procedures necessary to take the human factors considerations into account. There will be a particular emphasis on identifying the human-machine interface issue if there are any and providing the high risk mitigation strategies to account for them.

### **5.2 Training and Qualification Requirements**

**5.2.1** This module will eventually contain and number of personnel training requirements. As and when they are developed, they will be included in the documentation supporting this module and their importance signified. Likewise, any qualifications requirements that are recommended will become part of the regulatory needs prior to implementation of this performance improvement.

## **6. Regulatory/standardisation needs and Approval Plan (Air & Ground)**

- **Regulatory/Standardization:** To Be Determined
- **Approval Plans:** To Be Determined

## **7. Implementation and Demonstration Activities**

### **7.1 Current Use**

None at this time

### **7.2 Planned or On-going Trials**

None at this time

## **8. Reference Documents**

- ICAO Annex 2 — *Rules of the Air* (proposal for amendment);
- ICAO Annex 7 — *Aircraft Nationality and Registration Marks* (proposal for amendment);
- ICAO Circular 328 — *Unmanned Aircraft Systems (UAS)*;
- U.S. Department of Transportation FAA, Air Traffic Organization Policy, N JO 7210.766;
- NATO STANAG 4586, Standard Interfaces of UAV Control System (UCS) for NATO UAV Interoperability;EUROCAE Document (under development).

This Page Intentionally Left Blank

**Appendix C –  
Dependency Mandates**

DRAFT

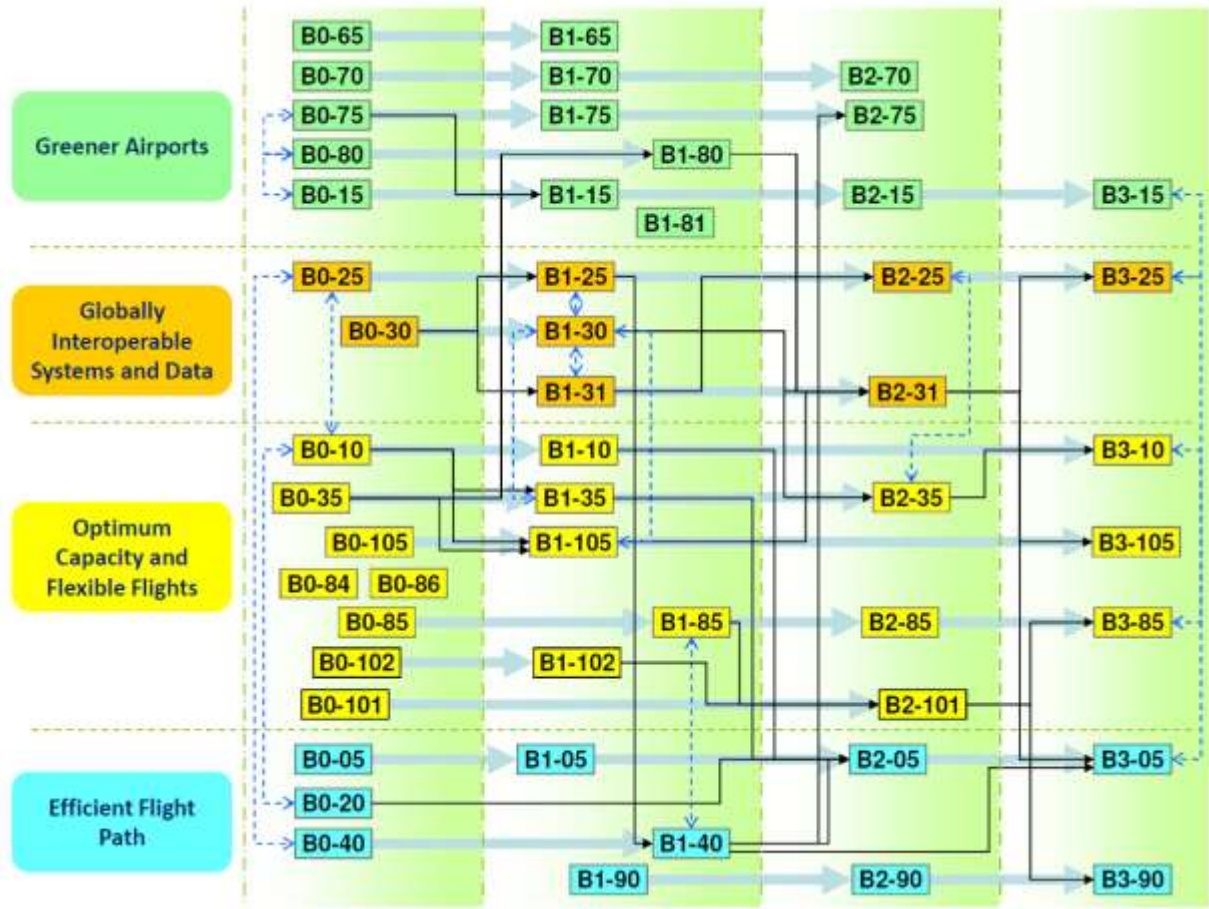

DR

## Appendix D - Glossary

DRAFT

This Page Intentionally Left Blank

DRAFT

**Appendix D- List of Acronyms****A**

**ATFCM.** Air traffic flow and capacity management

**AAR.** Airport arrival rate

**ABDAA.** Airborne detect and avoid algorithms

**ACAS.** Airborne collision avoidance system

**ACC.** Area control centre

**A-CDM.** Airport collaborative decision-making

**ACM.** ATC communications management

**ADEXP.** ATS data exchange presentation

**ADS-B.** Automatic dependent surveillance—broadcast

**ADS-C.** Automatic dependent surveillance — contract

**AFIS.** Aerodrome flight information service

**AFISO.** Aerodrome flight information service officer

**AFTN.** Aeronautical fixed telecommunication network

**AHMS.** Air traffic message handling System

**AICM.** Aeronautical information conceptual model

**AIDC.** ATS inter-facility data communications

**AIP.** Aeronautical information publication

**AIRB.** Enhanced traffic situational awareness during flight operations

**AIRM.** ATM information reference model

**AIS.** Aeronautical information services

**AIXM.** Aeronautical information exchange model

**AMA.** Airport movement area

**AMAN/DMAN.** Arrival/departure management

**AMC.** ATC microphone check

**AMS(R)S.** Aeronautical mobile satellite (route) service

**ANM.** ATFM notification message

**ANS.** Air navigation services

**ANSP.** Air navigation services provider

**AO.** Aerodrome operations/Aircraft operators

**AOC.** Aeronautical operational control

**AOM.** Airspace organization management

**APANPIRG.** Asia/Pacific air navigation planning and implementation regional group

**ARNS.** Aeronautical radio navigation Service

**ARNSS.** Aeronautical radio navigation Satellite Service

**ARTCCs.** Air route traffic control centers

**AS.** Aircraft surveillance

**ASAS.** Airborne separation assistance systems

**ASDE-X.** Airport surface detection equipment

**ASEP.** Airborne separation

**ASEP-ITF.** Airborne separation in trail follow

**ASEP-ITM.** Airborne separation in trail merge

**ASEP-ITP.** Airborne separation in trail procedure

**ASM.** Airspace management

**A-SMGCS.** Advanced surface movement guidance and control systems

**ASP.** Aeronautical surveillance plan

**ASPA.** Airborne spacing

**ASPIRE.** Asia and South Pacific initiative to reduce emissions

**ATC.** Air traffic control

**ATCO.** Air traffic controller

**ATCSCC.** Air traffic control system command center

**ATFCM.** Air traffic flow and capacity management

**ATFM.** Air traffic flow management

**ATMC.** Air traffic management control

**ATMRPP.** Air traffic management requirements and performance panel

**ATN.** Aeronautical Telecommunication Network

**ATOP.** Advanced technologies and oceanic procedures

**ATSA.** Air traffic situational awareness

**ATSMHS.** Air traffic services message handling services

**ATSU.** ATS unit

**AU.** Airspace user

**AUO.** Airspace user operations

## B

**Baro-VNAV.** Barometric vertical navigation

**BCR.** Benefit/cost ratio

**B-RNAV.** Basic area navigation

## C

**CSPO.** Closely spaced parallel operations

**CPDLC.** Controller-pilot data link communications

**CDO.** Continuous descent operations

**CBA.** Cost-benefit analysis

**CSPR.** Closely spaced parallel runways

**CM.** Conflict management

**CDG.** Paris - Charles de Gaulle airport

**CDM.** Collaborative decision-making

**CFMU.** Central flow management unit

**CDQM.** Collaborative departure queue management

**CWP.** Controller working positions

**CAD.** Computer aided design

**CTA.** Control time of arrival

**CARATS.** Collaborative action for renovation of air traffic systems

**CFIT.** Controlled flight into terrain

**CDTI.** Cockpit display of traffic information

**CCO.** Continuous climb operations

**CAR/SAM.** Caribbean and South American region

**COSESNA.** Central American civil aviation agency.

## D

**DAA.** Detect and avoid

**DCB.** Demand capacity balancing

**DCL.** Departure clearance

**DFM.** Departure flow management

**DFS.** Deutsche Flugsicherung GmbH

**DLIC.** Data link communications initiation capability

**DMAN.** Departure management

**DMEAN.** Dynamic management of European airspace network

**D-OTIS.** Data link-operational terminal information service

**DPI.** Departure planning information

**D-TAXI.** Data link TAXI

## E

**EAD.** European AIS database

**e-AIP.** Electronic AIP

**EGNOS.** European GNSS navigation overlay service

**ETMS.** Enhance air traffic management system

**EVS.** Enhanced vision systems

## F

**FABEC.** Functional Airspace Block Europe Central



**FAF/FAP.** Final approach fix/final approach point

**FANS.** Future air navigation systems

**FDP.** Flight data processing

**FDPS.** Flight data processing system

**FF-ICE.** Flight and flow information for the collaborative environment

**FIR.** Flight information region

**FIXM.** Flight information exchange model

**FMC.** Flight management computer

**FMS.** Flight management system

**FMTF.** Flight message transfer protocol

**FO.** Flight object

**FPL.** Filed flight plan

**FPS.** Flight planning systems

**FPSM.** Ground delay program parameters selection model

**FRA.** Free route airspace

**FTS.** Fast time simulation

**FUA.** Flexible use of airspace

**FUM.** Flight update message

## G

**GANIS.** Global Air Navigation Industry Symposium

**GANP.** Global air navigation plan

**GAT.** General air traffic

**GBAS.** Ground-based augmentation system

**GBSAA.** Ground based sense and avoid

**GEO satellite.** Geostationary satellite

**GLS.** GBAS landing system

**GNSS.** Global navigation satellite system

**GPI.** Global plan initiatives

**GPS.** Global positioning system

**GRSS.** Global runway safety symposium

**GUFU.** Globally unique flight identifier

## H

**HAT.** Height above threshold

**HMI.** Human-machine interface

**HUD.** Head-up display

## I

**IDAC.** Integrated departure-arrival capability

**IDC.** Interfacility data communications

**IDRP.** Integrated departure route planner

**IFR.** Instrument flight rules

**ILS.** Instrument landing system

**IM.** Interval Management

**IOP.** Implementation and Interoperability

**IP.** Internetworking protocol

**IRR.** Internal rate of return

**ISRM.** Information service reference model

**ITP.** In-trail-procedure

## K

**KPA.** Key performance areas

## L

**LARA.** Local and sub-regional airspace management support system

**LIDAR.** Aerial laser scans

**LNAV.** Lateral navigation

**LoA.** Letter of agreement

**LoC.** Letter of coordination

**LPV.** Lateral precision with vertical guidance OR localizer performance with vertical guidance

**LVP.** Low visibility procedures

## M

**MASPS.** Minimum aviation system performance standards

**MILO.** Mixed integer linear optimization

**MIT.** Miles-in-trail

**MLS.** Microwave landing system

**MLTF.** Multilateration task force

**MTOW.** Maximum take-off weight

## N

**NADP.** Noise abatement departure procedure

**NAS.** National airspace system

**NAT.** North Atlantic

**NDB.** Non-directional radio beacon

**NextGen.** Next generation air transportation system

**NMAC.** Near mid-air collision

**NOP.** Network operations procedures (plan)

**NOTAM.** Notice to airmen

**NPV.** Net present value

## O

**OLDI.** On-line data interchange

**OPD.** Optimized profile descent

**OSD.** Operational service & environment definition

**OTW.** Out the window

## P

**P(NMAC).** Probability of a near mid-air collision

**PACOTS.** Pacific organized track system

**PANS-OPS.** Procedures for air navigation services - aircraft operations

**PBN -** Performance-based navigation

**PENS** Pan-European Network Service

**PETAL.** Preliminary EUROCONTROL test of air/ground data link

**PIA.** Performance improvement area

**P-RNAV.** Precision area navigation

## R

**RA.** Resolution advisory

**RAIM.** Receiver autonomous integrity monitoring

**RAPT.** Route availability planning tool

**RNAV** Area navigation

**RNP.** Required navigation performance

**RPAS.** Remotely-piloted aircraft system

**RTC.** Remote tower centre

## S

**SARPs.** Standards and recommended practices

**SASP.** Separation and airspace safety panel

**SATCOM.** Satellite communication

**SBAS.** Satellite-based augmentation system

**SDM.** Service delivery management

**SESAR.** Single European sky ATM research

**SEVEN.** System-wide enhancements for versatile electronic negotiation

**SFO.** San Francisco international airport

**SIDS.** Standard instrument departures

**SMAN.** Surface management

**SMS.** Safety management systems

**SPRs.** Special programme resources

**SRMD.** Safety risk management document

**SSEP.** Self-separation

**SSR.** Secondary surveillance radar

**STA.** Scheduled time of arrival

**STARS.** Standard terminal arrivals

**STBO.** Surface trajectory based operations

**SURF.** Enhanced traffic situational awareness on the airport surface

**SVS.** Synthetic visualisation systems

**SWIM.** System-wide information management

## T

**TBD.** To be determined

**TBFM.** Time-based flow management

**TBO.** Trajectory-based operations

**TCAS.** Traffic alert and collision avoidance system

**TFM.** Traffic flow management

**TIS-B.** Traffic information service-broadcast

**TMA.** Trajectory management advisor

**TMI.** Traffic management initiatives

**TMU.** Traffic management unit

**TOD.** Top of Descent

**TRACON.** Terminal radar approach control

**TS.** Traffic synchronization

**TSA.** Temporary segregated airspace

**TSO.** Technical standard order

**TWR.** Aerodrome control tower

## U

**UA.** Unmanned aircraft

**UAS.** Unmanned aircraft system

**UAV.** Unmanned aerial vehicle

**UDPP.** User driven prioritisation process

## V

**VFR.** Visual flight rules

**VLOS.** Visual line-of-sight

**VNAV.** Vertical navigation

**VOR.** Very high frequency (VHF) omnidirectional radio range

**VSA.** Enhanced visual separation on approach

## W

**WAAS.** Wide area augmentation system

**WAF.** Weather avoidance field

**WGS-84.** World geodetic system - 1984

**WIDAO.** Wake independent departure and arrival operation

**WTMA.** Wake turbulence mitigation for arrivals

**WTMD.** Wake turbulence mitigation for departures

**WXXM.** Weather exchange model

This Page Left Intentionally Blank

DRAFT

